

**PORT OF BROOKINGS HARBOR
CURRY COUNTY, OREGON**

RESOLUTION NO. 2021-14

**A RESOLUTION OF THE BOARD OF PORT COMMISSIONERS FOR THE PORT OF
BROOKINGS HARBOR AUTHORIZING SUBMISSION OF BUSINESS OREGON
GENERAL APPLICATION FOR SPECIAL PUBLIC WORKS FUND, FEMA DR-4452
MITIGATION AND REPAIR, #648-14633**

WHEREAS, the Port of Brookings Harbor is a port district, organized and operated under the provisions of ORS Chapter 777, and has the authority to adopt resolutions; and

WHEREAS, a severe storm occurred on April 6, 2019 causing enough damage in Curry County and to the Port to activate FEMA disaster relief protocol for which the Port submitted storm damage of approximately 30,000 cubic yards of sediment deposited in Basins 1 and 2. FEMA 406 Mitigation measures will provide infrastructure to reduce future storm related damages to Port facilities; and

WHEREAS, FEMA disaster relief requires 25% matching from the applicant for the repair and mitigation costs. The Port does not have the funds required for the 25% matching.; and

WHEREAS, Business Oregon Special Public Works Fund provides matching amounts for disaster relief repair and mitigation projects.

NOW, THEREFORE, be it resolved by the Board of Commissioners of the Port of Brookings Harbor, Curry County, Oregon as follows:

1. The Port of Brookings Harbor Board of Commissioners authorizes the Board President, Richard Heap, to sign and submit on the behalf of the Port of Brookings Harbor, Business Oregon General Application for Special Works Fund, FEMA DR-4452 Mitigation and Repair, #648-14633.

APPROVED AND ADOPTED and made effective the same day by the Board of Port Commissioners of the Port of Brookings Harbor this 17th day of November, 2021.

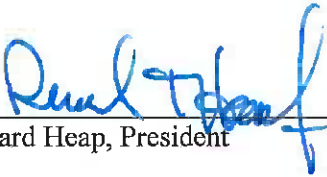

Richard Heap, President

ATTEST:



Sharon Hartung, Secretary/Treasurer



November 9, 2021

Richard Heap, President
Port of Brookings Harbor
16330 Lower Harbor Rd.
PO Box 848
Brookings, Oregon, 97415

RE: Invitation to Apply for Special Public Works Fund, FEMA DR-4452 Mitigation and Repair,
#648-14633

Dear Richard:

Business Oregon is pleased to invite you to submit an application for funding for the above referenced project.

Please submit the enclosed Application and the Application Supplement form(s) to our office.

We request that you complete the Application and Application Supplement within 45 days of receiving this letter.

Should you have any questions, please contact me at 503-779-3221 or e-mail to: Ted.Werth@oregon.gov I will be your Business Oregon point of contact for this project moving forward.

Sincerely,

Ted Werth

Ted Werth, Regional Project Manager
Business Oregon

Enclosures

c: Gary Dehlinger
File



General Application

775 Summer St NE, Suite 200
Salem, OR 97301-1280

Applicant

Port of Brookings Harbor
Name

93-6013807
Federal Tax ID Number

16330 Lower Harbor Road, Brookings, OR
97415
Street Address

P.O. Box 848, Brookings, OR 97415
Mailing Address

Organization Type:

City County Special District under
ORS _____

Port District under
ORS 777

Tribe

Gary Dehlinger
Contact Name
(Person we should contact with project questions)

Port Manager
Title

541-254-4162
Phone Number

541-359-3999
Fax Number

portmanager@portofbrookingshar
bor.com
Email Address

Representation (Information may be found at www.leg.state.or.us/findlegsltr)

01
Senate District Number

Dallas Heard
Senator's Name

01
House District Number

David Brock Smith
Representative's Name

Project Information

FEMA DR-4452 Mitigation & Repair, #648-14633
Project Name: (e.g., Stayton Water System Improvements)

Opportunity/Problem

Briefly describe the opportunity or problem facing the applicant:

A severe storm occurred on April 6, 2019 causing enough damage in Curry County and to the Port to activate FEMA disaster relief protocol for which the Port submitted storm damage of approximately 30,000 cubic yards of sediment deposited in Basins 1 and 2. FEMA 406 Mitigation measures will provide infrastructure to reduce future storm related damages to Port facilities. FEMA disaster relief requires 25% matching from the applicant for the repair and mitigation costs. The Port does not have the funds required for the 25% matching.

Response to Opportunity/Problem

Briefly describe the major alternatives considered to address this opportunity or problem:

The Port would need to seek private loans for the required 25% matching and cause further debt issues.

Detailed Project Description

Clearly describe the proposed project work to be accomplished:

Please see Attachment "B" report from EMC Engineers/Scientists dated 5/16/2021.

Project Work Plan

List project activity milestones with estimated start and completion dates. Identify estimated date of first cash draw:

Activity	Estimated Date	
	Start	Completion
Joint Permit Applicant approved	Nov 1, 2021	Jan 1, 2022
Completion of construction drawings	Nov 1, 2021	Sep 1, 2022
Purchase of dredge, electric generator and piping	Jan 1, 2022	Sep 1, 2022
RFP to select project contractor	May 1, 2022	Jul 1, 2022
Grading and construction of the sediment storage area in the Commercial area	Jul 1, 2022	Sep 1, 2022
Dredging Basins 1 & 2	Oct 1, 2022	Mar 1, 2024
Basin 2 Slope Repairs	Oct 1, 2022	Mar 1, 2023
Mitigation Repairs	Mar 1, 2023	Jan 1, 2025

Estimated First Draw Date: Feb 1, 2022

Project Budget

List individual project budget line items with requested budgeted amounts by IFA and non-IFA funding sources. Change budget column labels to identify the specific requested IFA funding sources. Non-IFA sources are those funds other than those requested from IFA.

Please be aware that the award loan amount will be subject to a less than 1% issuance fee if the loan is included in the Oregon Bond Bank. Please contact Business Oregon for additional information.

Budget Line Item (Adjust budget items to suit the project) <i>Below are general items most used</i>	IFA Funding		Non-IFA Funds	Total
	Source 1	Source 2		
Engineering/Architecture	\$0	\$0	\$0	\$0
Construction	458,934		1,376,800	1,835,734
Construction Contingency				0
Land Acquisition				0
Legal				0
Construction Management				0
Other (Specify)				0
Other (Specify)				0
Other (Specify)				0
Other (Specify)				0
Totals	458,934	0	1,376,800	1,835,734

Note: Attach Engineer's Cost Estimate completed within the past 6 months.

Details of Non-IFA Funds

Source of Non-IFA Funds	Amount	Status: C-Committed, A-Application S-Submitted, AI-Application Invited, PS-Potential Source	Dates Required Funds will be Committed and Available
FEMA/OEM	\$1,376,800	S	1-Jan-22
Totals	1,376,800		

If "Non-IFA funds" include USDA Rural Development funding that will require interim financing, please indicate the source of the interim financing.

General Certification

I certify to the best of my knowledge all information, contained in this document and any attached supplements, is valid and accurate. I further certify that, to the best of my knowledge:

1. The application has been approved by the governing body or is otherwise being submitted using the governing body's lawful process, and
2. Signature authority is verified.

Check one:

- Yes, I am the highest elected official. (e.g., Mayor, Chair or President)
- No, I am not the highest elected official so I have attached documentation that verifies my authority to sign on behalf of the applicant. (Document such as charter, resolution, ordinance or governing body meeting minutes must be attached.)

The department will only accept applications with proper signature authority documentation.



Signature

November 17, 2021

Date

Richard Heap

Printed Name

President

Printed Title

FOR BUSINESS OREGON USE ONLY

Concept Number

Intake Approval Date

Project Type:

- Planning
- Construction
- Other:
- Design
- Design & Construction

Applicant: Port of Brookings Harbor

Project Name: FEMA DR-4452 Mitigation & Repair, #648-14633

Section I: Project Type / Acquisition / Ownership / Operation

- A. Will the project provide the local match for an **emergency project** receiving federal disaster relief? Yes No
If yes, briefly describe the emergency project activities: Dredging, Basin slope repair and mitigation measures.
Note: Attach copies of the FEMA approved "Project Worksheets" as Attachment A.
- B. Will the project result in the restoration, rehabilitation or new construction of essential community facilities that provide support services to public health and safety, including but limited to police and fire protection, medical treatment, public utilities, transportation and auxiliary shelter facilities? Yes No
If yes, explain:
- C. What is the physical location of the project?
16330 Lower Harbor Road and 16035 Boat Basin Road, Brookings, OR 97415
- D. Will the applicant own the facility / improvements once constructed? Yes No
If no, explain:
- E. Will the applicant operate and maintain the facility / improvements once constructed? Yes No
If no, describe:
- F. Does the project include any acquisition of real property, including permanent easements and rights-of-way, which are directly related to or necessary for the project? Yes No
If yes, describe:
- G. Does the project include the purchase of motor vehicles or any other equipment which is essential to the project? Yes No
If yes, describe: Remote control dredge, generator and discharge piping
- H. Will a private entity or business have a special legal entitlement to the project? (e.g., through either a transfer of, or partnership in ownership, a lease, management contract, special user rates or development fees, or priority for use) Yes No
If yes, describe:

Section II: Additional Project Information

A. What is the estimated useful life of the improvements included in the project?

50-100 years

B. Please list the permits and regulatory authorizations needed for the project to be ready to proceed with construction and indicate whether they have been obtained or not.

Permit Type	Review Agency	Status of Approval	If pending, anticipated approval date
Joint Permit Application	USACE & ODSL	<input type="checkbox"/> Obtained <input checked="" type="checkbox"/> Pending	Jan 1, 2022
		<input type="checkbox"/> Obtained <input type="checkbox"/> Pending	
		<input type="checkbox"/> Obtained <input type="checkbox"/> Pending	
		<input type="checkbox"/> Obtained <input type="checkbox"/> Pending	

Section III: For Drinking Water System Improvement Projects Only

A. Water system identification number:

Section IV: Financial Information

A. What sources of revenue can be pledged to repay a loan?

*Note: Loan funding for all or a portion of the requested local match **may** be necessary if funding requests for local match assistance exceeds the Emergency Project grant funds available.*

Port's understanding, FEMA declared disaster matching from SPWF is not a loan.

B. Is other debt serviced or secured by those revenues? Yes No

If yes, is the other debt described in the applicant's audit reports? Yes No

If the other debt is not described in the audit report, refer to the specific authorization, such as an ordinance or resolution. List below and attach a copy.

Lender	Amount of Note	Year Incurred

C. Has the applicant ever defaulted on a debt? Yes No

If yes, provide a complete summary of the circumstances related to the default:

- D. Is there actual/pending litigation that could impair the applicant's ability to repay debt? Yes No

If yes, describe:

Section V: Budget Information

- A. Does the project budget (as included on the General Application) propose direct project management expenses? Yes No

(Direct project management is defined as expenses that will be incurred that are directly related to and necessary solely to support or manage project activities and are not routine or ongoing expenses of the municipality or expenses for current staff that are already included in the municipality's adopted budget.)

If yes, describe how the direct project management services will be provided:

- B. A current engineer's cost estimate must be included as **Attachment G**. Who prepared the cost estimates for the project?

Note: To be considered current, the cost estimate must have been completed within the past 6 months.

Name: **Jack Akin**

Title: **Owner**

Company: **EMC Engineers/Scientists, LLC**

Phone Number: **541-474-9434**

Date of project cost estimate: **May 16, 2021**

Attachments

	Attachment Description	For IFA Use (X Attached?)
Required with all applications	A Attach a copy of the FEMA approved "Project Worksheet(s)" that are the basis for this funding request.	<input type="checkbox"/>
	B Map(s) showing the location of the project, including tax lots / parcels and road widths, et cetera.	<input type="checkbox"/>
	C If the project overlaps municipal boundaries, attach an executed copy of an intergovernmental cooperation agreement that sets out the duties and obligations of each entity.	<input type="checkbox"/>
	D If the applicant will own the facility and another entity will operate the facility, attach an executed copy of the operating agreement between the parties.	<input type="checkbox"/>
	E If available, the plans and specifications for the project.	<input type="checkbox"/>
	F If available, the architectural / engineering / planning work or study conducted to determine the feasibility of the proposed repairs or other improvements. The documents must be certified by a professional architect / registered engineer licensed in Oregon.	<input type="checkbox"/>
	G Current engineer's cost estimate (see Section 5 B)	<input type="checkbox"/>

304670

Harbor - Basins 1 and 2

*****Version 1 Summary*****

Version 1 captures work to be completed and supersedes Version 0 SOW.

V1.1 Total volume of debris to be removed increased from 8,000 CY to 38,000 CY after detailed engineering analysis and transfer of project 110140 SOW to this project (see special note 1).

V1.2: Riprap replacement added to SOW as part of dredging work, determined necessary after detailed engineering analysis.

V1.3: Work to be completed costs have increased from \$972,299.00 to \$2,465,157.00 due to above changes.

V1.4: Include \$80,400 of transferred de-obligated funding from DR4452, project 110140.

Work to be Completed

The applicant will utilize contracts for the repairs to harbor Basins 1 and 2 to return the facility back to its pre-disaster design, function and capacity within the existing footprint.

Basin 1 GPS: 42.047097, -124.266318 through 42.044543, -124.264013

Basin 2 GPS: 42.051155, -124.268378 through 42.050387, -124.268139

Facility Damage

1. Remove and dispose of 8,000 Cubic Yard of Sand/Soil/Mud debris from Basin 1.
2. Remove and dispose of 30,000 Cubic Yard of Sand/Soil/Mud debris from Basin 2.
3. Replace 1911 CY of riprap in Basin 2 :
 1. 542 CY of unclassified mixed riprap on East slope, 195 FT long x 5 FT wide x 15 FT deep
 2. 578 CY of unclassified mixed riprap on South Slope, 208 FT long x 5 FT wide x 15 FT deep
 3. 289 CY of unclassified mixed riprap on Transient Slope, 104 FT long x 5 FT wide x 15 FT deep
 4. 502 CY of unclassified mixed riprap on Basin 2 West Slope, 452 FT long x 5 FT wide x 6 FT deep

Work to be Completed Total: \$2,465,157.00

Special Notes:

1. The actual dredging work of this project is directly associated with the dredging work of Project #110140 of DR4452OR, therefore the Engineering Services include the composite design documents for both damages. The projects are not mutually exclusive (e.g. as the sediment of the first event DR4432 is

beneath the sediment of DR4452, it technically cannot be removed until the DR4452 sediment is removed), thus the need for a combined engineering program.

Project Notes:

1. All site estimates for work to be completed were generated using applicant provided estimates. See attachment labelled *ST 104046 Cost Validation.xlsx* and *ST 104046 Appendix A Cost Validation Checklist.pdf*
2. As engineering design evolved, total volume of debris has become more accurate and volume totals are now 38,000 CY for projects 104046 and 110140.
3. The updated SOW includes 1911 CY of replacement riprap, determined necessary after detailed engineering analysis
4. Applicant plans to use a an in-house, small dredge system, utilizing the DragFlow DPR-120 remote controlled dredge, rigged with the EL 1204HH C Model pump system. See attached document *DR4432 & DR4452_POBH_Repairs, Mitigation, Exhibits DWGs and Budgets.pdf*, page 26.
5. The applicant is coordinating with US Army Corp of Engineers and Oregon Department of Public Lands regarding required permits. See attached document *DR4432_DR4452_Port of Brookings Harbor_JPA_071321.pdf*
6. All work will be completed within the applicants ROW. If staging of equipment and materials would be needed, that work will be staged within the applicants ROW.
7. Disposal of work to be completed is expected to be deposited at an acceptable location (landfill). Location will be provided by applicant once work commences.
8. All borrow, or fill must come from pre-existing stockpiles, material reclaimed from maintained roadside ditches (provided the designed width or depth of the ditch is not increased), or commercially procured material from a source existing prior to the event. For any FEMA-funded project requiring the use of a non-commercial source or a commercial source that was not permitted to operate prior to the event (e.g. a new pit, agricultural fields, road ROWs, etc.) in whole or in part, regardless of cost, the Applicant must notify FEMA and the Recipient prior to extracting material. FEMA must review the source for compliance with all applicable federal environmental planning and historic preservation laws and executive orders prior to a sub recipient or their contractor commencing borrow extraction. Consultation and regulatory permitting may be required. Non-compliance with this requirement may jeopardize receipt of federal funding. Documentation of borrow sources utilized is required at closeout.
9. Construction Date of Basin 1 is 1950s – 1960s, the construction date of Basin 2 is 1975 and the construction date of the Fuel Dock is 2004/2010.”
10. The EHP site inspection report uploaded to GM references major archeological concerns along east bank of Basin 1 and north of Basin 2 as well as some environmental concerns.
11. This project was moved to category G and qualifies for hazard mitigation funding, however the DI is still listed as category A thus this SOW is implementing an agreed-upon work-around to include the proposed Hazard Mitigation Proposal (HMP). See below.

Hazard Mitigation Proposal (HMP)

GM Project # 104046

DI #: 304670

DR-4432- OR

HMP Date: 10/4/2021

Damage Description & Dimensions (DDD):

This permanent work project addresses dredging work and rip rap replacement following two storm events, with a total estimated repair cost of \$2,465,157. The damages occurred from the displacement of all of the materials from upslope during heavy precipitation and winter storm

events. An engineering analysis (DR4432 & DR4452_POBH_Repairs, Mitigation, Exhibits DWGs and Budgets.pdf) was conducted to provide the details regarding the repairs needed and the proposed mitigation.

Hazard Mitigation Proposal (HMP) Scope of Work

For the purpose of erosion control to mitigate against future damages from similar events, the applicant has provided a detailed scope of work which includes resiliency measures upslope that are in keeping with Appendix J section I.B as well as a lesser cost method of repair for the damages their selves. This holistic approach of addressing the repairs and resiliency will result in mitigation that addresses the causes and source of the disaster related damages. See previously mentioned attachment for details.

Hazard Mitigation Proposal (HMP) Cost:

The applicant provided estimate for the mitigation is Exhibit C, found on page 11 of 105 within the engineering analysis. Due to the various approaches used in compartmentalizing the funding, the information on that estimate regarding where the funding could come from should be disregarded as no longer representing the best available information. The cost, designs, and items included remain valid. The cost of the proposed mitigation is derived previously noted attachments, for \$3,833,249. This mitigation will be performed in lieu of the predisaster repair. Therefore, the total additional cost needed for this mitigation is: $\$3,833,249$ minus $\$2,465,157 = \$1,368,092$.

Hazard Mitigation Ratio:

The estimated predisaster repairs (excluding engineering) is \$2,465,157. The proposed mitigation is \$1,368,092, or 55% of the repair costs.

HMP Feasibility & Cost Effectiveness:

This Hazard Mitigation Proposal is cost effective in accordance with the 100% Rule, FEMA Public Assistance Program and Policy Guide (PAPPG) V3.1 and Appendix J section I.B.

Compliances and Assurances:

The Applicant is responsible for permits and compliance with all regulatory codes and standards for the State of Oregon and contractors and vendors. FEMA will not pay for duplication of cost between repairs and mitigation measures. If this HMP is approved to change SOW, the Applicant must apply for a change in SOW so FEMA can review to ensure program compliance.

portmanager@portofbrookingsharbor.com

From: SLEVIN Julie * OMD <julie.slevin@mil.state.or.us>
Sent: Tuesday, October 19, 2021 9:22 AM
To: 'Jack '; portmanager@portofbrookingsharbor.com
Cc: GWIN Dan * OMD
Subject: FW: DR4432/4452 - POBH: DREDGING projects #104046 & 110140
Attachments: DR4432-POBH Project#104046-V1 Dredging Amendment SOW.docx

FYI

From: WERTH Ted * BIZ <Ted.Werth@oregon.gov>
Sent: Monday, October 18, 2021 4:45 PM
To: SLEVIN Julie * OMD <julie.slevin@mil.state.or.us>
Subject: Re: DR4432/4452 - POBH: DREDGING projects #104046 & 110140

Julie,

This is very helpful. I'll be in touch once I have a chance to look at this closer and discuss with the program manager who oversees SPWF program. It should be later this week.

Thanks,
Ted

Ted Werth
Regional Project Manager
503-779-3221

From: SLEVIN Julie * OMD <julie.slevin@mil.state.or.us>
Sent: Monday, October 18, 2021 1:33:39 PM
To: WERTH Ted * BIZ <Ted.Werth@oregon.gov>
Cc: GWIN Dan * OMD <dan.gwin@mil.state.or.us>
Subject: FW: DR4432/4452 - POBH: DREDGING projects #104046 & 110140

Hi Ted, per our discussion, I think a couple of weeks ago, attached is the two projects into for Port of Brookings Harbor. Does this help with POBH grant limitations?

Please let me know if you have any questions,

Julie Slevin
503.378.2235

From: Grant, Douglas <Douglas.Grant@fema.dhs.gov>
Sent: Monday, October 18, 2021 1:28 PM
To: SLEVIN Julie * OMD <julie.slevin@mil.state.or.us>
Cc: Michaels, Steven <Steven.Michaels@fema.dhs.gov>; McCartney, Scott <Scott.Mccartney@fema.dhs.gov>; Kerschke, William <William.Kerschke@fema.dhs.gov>; Johnson III, Lawrence <lawrence.johnsoniii@fema.dhs.gov>; GWIN Dan * OMD <dan.gwin@mil.state.or.us>; Gregory Jackson <gjackson@acdisaster.com>; Lucas Pagan <lpagan@acdisaster.com>; Marusin, Lee <lee.marusin@fema.dhs.gov>; Leigh, Jordan <jordan.leigh@fema.dhs.gov>;

Malone, Jack <Jack.Malone@fema.dhs.gov>; Talbot, Jessica <jessica.talbot@fema.dhs.gov>
Subject: RE: DR4432/4452 - POBH: DREDGING projects #104046 & 110140

Hi Julie,

Attached is the updated/amended Scope-of-Work for project #104046, which describes the combined dredging work and mitigation measures of the merged projects. We trust this information will meet the requirements of OR Biz. If additional documentation is needed please let us know, at your earliest convenience. Thank you. Doug

Douglas C Grant
PDMG -- Public Assistance
DR4432OR
732-804-9239
Douglas.grant@fema.dhs.gov

From: Marusin, Lee <lee.marusin@fema.dhs.gov>
Sent: Thursday, September 16, 2021 2:47 PM
To: SLEVIN Julie * OMD <julie.slevin@mil.state.or.us>; Grant, Douglas <Douglas.Grant@fema.dhs.gov>; Leigh, Jordan <jordan.leigh@fema.dhs.gov>; Malone, Jack <Jack.Malone@fema.dhs.gov>
Cc: Michaels, Steven <Steven.Michaels@fema.dhs.gov>; McCartney, Scott <Scott.Mccartney@fema.dhs.gov>; Kerschke, William <William.Kerschke@fema.dhs.gov>; Johnson III, Lawrence <lawrence.johnsoniii@fema.dhs.gov>; GWIN Dan * OMD <dan.gwin@mil.state.or.us>; Gregory Jackson <gjackson@acdisaster.com>; Lucas Pagan <lpagan@acdisaster.com>
Subject: RE: DR4432/4452 - POBH: DREDGING projects #104046 & 110140

Hi All,

Per my discussion with Julie S., I have approved the POBH Amendment Request for the Dredging projects. Business Oregon will need an explanation covering two projects consolidated into one so that the Applicant will be able to receive support from Biz Oregon in support of both.

Let me know if you have any questions.

Thank you.

L.

Lee M. Marusin
DR4519 OR PD TFL
lee.marusin@fema.dhs.gov
FEMA Mobile 202-615-6193

From: SLEVIN Julie * OMD <julie.slevin@mil.state.or.us>
Sent: Thursday, September 16, 2021 12:34 PM
To: Marusin, Lee <lee.marusin@fema.dhs.gov>; Grant, Douglas <Douglas.Grant@fema.dhs.gov>; Leigh, Jordan <jordan.leigh@fema.dhs.gov>; Malone, Jack <Jack.Malone@fema.dhs.gov>
Cc: Michaels, Steven <Steven.Michaels@fema.dhs.gov>; McCartney, Scott <Scott.Mccartney@fema.dhs.gov>; Kerschke, William <William.Kerschke@fema.dhs.gov>; Johnson III, Lawrence <lawrence.johnsoniii@fema.dhs.gov>; GWIN Dan * OMD <dan.gwin@mil.state.or.us>; Gregory Jackson <gjackson@acdisaster.com>; Lucas Pagan <lpagan@acdisaster.com>
Subject: RE: DR4432/4452 - POBH: DREDGING projects #104046 & 110140

Hi Lee, all, do you have a write up for the scope of work that documents the combination of both projects combined into one? I just talked to OR Biz who is looking at funding the match for the Port, all OR Biz really needs is a description on

how two projects/two events have been combined into one project, this will document that this is two projects, therefore match may be able to rolled together.

From: Marusin, Lee <lee.marusin@fema.dhs.gov>
Sent: Thursday, September 16, 2021 11:06 AM
To: Grant, Douglas <Douglas.Grant@fema.dhs.gov>; SLEVIN Julie * OMD <julie.slevin@mil.state.or.us>; Leigh, Jordan <jordan.leigh@fema.dhs.gov>; Malone, Jack <Jack.Malone@fema.dhs.gov>
Cc: Michaels, Steven <Steven.Michaels@fema.dhs.gov>; McCartney, Scott <Scott.Mccartney@fema.dhs.gov>; Kerschke, William <William.Kerschke@fema.dhs.gov>; Johnson III, Lawrence <lawrence.johnsoniii@fema.dhs.gov>; GWIN Dan * OMD <dan.gwin@mil.state.or.us>; Gregory Jackson <gjackson@acdisaster.com>; Lucas Pagan <lpagan@acdisaster.com>
Subject: RE: DR4432/4452 - POBH: DREDGING projects #104046 & 110140

Thanks Doug,

Will review but wait for additional info before advancing.

Thanks.

Lee

From: Grant, Douglas <Douglas.Grant@fema.dhs.gov>
Sent: Thursday, September 16, 2021 11:04 AM
To: SLEVIN Julie * OMD <julie.slevin@mil.state.or.us>; Leigh, Jordan <jordan.leigh@fema.dhs.gov>; Malone, Jack <Jack.Malone@fema.dhs.gov>
Cc: Michaels, Steven <Steven.Michaels@fema.dhs.gov>; Marusin, Lee <lee.marusin@fema.dhs.gov>; McCartney, Scott <Scott.Mccartney@fema.dhs.gov>; Kerschke, William <William.Kerschke@fema.dhs.gov>; Johnson III, Lawrence <lawrence.johnsoniii@fema.dhs.gov>; GWIN Dan * OMD <dan.gwin@mil.state.or.us>; Gregory Jackson <gjackson@acdisaster.com>; Lucas Pagan <lpagan@acdisaster.com>
Subject: RE: DR4432/4452 - POBH: DREDGING projects #104046 & 110140
Importance: High

ALL,

The amendment request for project#104046 (DR4432) has been prepared and is entered into Grants Manager/Grants Portal. Please feel free to review it, but not advance it in the process until we have an answer to the following issue raised by the Applicant-POBH:

From: Grant, Douglas <Douglas.Grant@fema.dhs.gov>
Sent: Monday, September 13, 2021 1:49 PM
To: Marusin, Lee <lee.marusin@fema.dhs.gov>
Subject: FW: DR4432-POBH: -- RE: DR4432/Engineering-Permitting Assistance

Lee,

Just got off the phone with Jack Akin (EMC Engineering). He said Gary D (Port Mgr) is concerned that the State supposedly has a matching fund limit per project of \$500,000; and if we consolidate the projects they might lose out on \$500,000? I told him I hadn't heard of that, but I felt he should contact Julie for clarification, and he said would and keep me in the loop. [9/16: I haven't heard back from Jack A]

As soon as the State provides the clarification we'll know whether or not to advance this request. In the meantime, presuming the answer is "no, POBH will not lose out on \$500k", I am drafting the amendment request needed to de-obligate the \$80,400 A&E Services funding from project#110140 (DR4452), so it can be transferred to DR4432.

If anyone has questions, comments or other input please share with the entire group. Thanks for your help.
..... Doug

Douglas C Grant
PDMG – Public Assistance
DR4432OR
732-804-9239
Douglas.grant@fema.dhs.gov

From: SLEVIN Julie * OMD <julie.slevin@mil.state.or.us>
Sent: Thursday, September 9, 2021 1:03 PM
To: Leigh, Jordan <jordan.leigh@fema.dhs.gov>; Malone, Jack <Jack.Malone@fema.dhs.gov>
Cc: Michaels, Steven <Steven.Michaels@fema.dhs.gov>; Marusin, Lee <lee.marusin@fema.dhs.gov>; McCartney, Scott <Scott.Mccartney@fema.dhs.gov>; Kerschke, William <William.Kerschke@fema.dhs.gov>; Johnson III, Lawrence <lawrence.johnsoniii@fema.dhs.gov>; GWIN Dan * OMD <dan.gwin@mil.state.or.us>; Grant, Douglas <Douglas.Grant@fema.dhs.gov>
Subject: RE: DR4432/4452 - POBH: DREDGING projects #104046 & 110140

Thank you Jordan! What you wrote below was my understanding. In regards to the 4452 to 4432, I believe deob and move to 4432 was the plan.

From: Leigh, Jordan <jordan.leigh@fema.dhs.gov>
Sent: Thursday, September 9, 2021 12:21 PM
To: Malone, Jack <Jack.Malone@fema.dhs.gov>
Cc: Michaels, Steven <Steven.Michaels@fema.dhs.gov>; Marusin, Lee <lee.marusin@fema.dhs.gov>; McCartney, Scott <Scott.Mccartney@fema.dhs.gov>; Kerschke, William <William.Kerschke@fema.dhs.gov>; Johnson III, Lawrence <lawrence.johnsoniii@fema.dhs.gov>; GWIN Dan * OMD <dan.gwin@mil.state.or.us>; SLEVIN Julie * OMD <julie.slevin@mil.state.or.us>; Grant, Douglas <Douglas.Grant@fema.dhs.gov>
Subject: RE: DR4432/4452 - POBH: DREDGING projects #104046 & 110140

Hey Jack/All, I spoke with Lee again this morning and I think we're all on the same page. We will be requesting an amendment for 4432 and that is the one that we will capture all the costs, and mitigation in.

The only question that remained is regarding the funding already obligated under 4452 and whether or not we would need to write an amendment to move those funds from one disaster to another, or choose to leave them where they are. My opinion was that we would need to de-obligate the funds from 4452 and move them over to 4432 but I am not the Region and that would be a question for Steve, and the fabulous Region 10 closeout team.

Thank you,

Jordan Leigh
Lane Manager | Consolidated Resource Center, West | Public Assistance Division
Mobile: (202) 856-5928
Jordan.Leigh@fema.dhs.gov

Federal Emergency Management Agency
fema.gov



FEMA

From: Malone, Jack <Jack.Malone@fema.dhs.gov>
Sent: Wednesday, September 8, 2021 4:34 PM
To: Leigh, Jordan <jordan.leigh@fema.dhs.gov>
Cc: Michaels, Steven <Steven.Michaels@fema.dhs.gov>; Marusin, Lee <lee.marusin@fema.dhs.gov>; McCartney, Scott <Scott.Mccartney@fema.dhs.gov>; Kerschke, William <William.Kerschke@fema.dhs.gov>; Johnson III, Lawrence <lawrence.johnsoniii@fema.dhs.gov>; GWIN Dan * OMD <dan.gwin@mil.state.or.us>; SLEVIN Julie * OMD <julie.slevin@mil.state.or.us>; Grant, Douglas <Douglas.Grant@fema.dhs.gov>
Subject: RE: DR4432/4452 - POBH: DREDGING projects #104046 & 110140

Good Afternoon – Jordan -

To weigh in on all this – it appears that all the necessary information is available and was attached on 7/14/21 under 4432 project #104046. There were 3 attachments total that were added.

Therefore – it seems the operative question is – what is the SOP for initiating a version on an obligated project for an applicant that has not had an RTM? Does it need to be a formal amendment request from the Grantee, or is there some more direct way that we could proceed forward on this? Can you advise or redirect to someone who could advise? I think we know where we want to go – we just need some direction on how to go about getting there.

Jack B. Malone
 Emergency Management, HM 406| FEMA
 Mobile: (202)805 - 7186
 e-mail: jack.malone@fema.dhs.gov

Federal Emergency Management Agency
www.FEMA.gov



FEMA

From: SLEVIN Julie * OMD <julie.slevin@mil.state.or.us>
Sent: Tuesday, September 7, 2021 2:51 PM
To: Leigh, Jordan <jordan.leigh@fema.dhs.gov>; Grant, Douglas <Douglas.Grant@fema.dhs.gov>
Cc: Michaels, Steven <Steven.Michaels@fema.dhs.gov>; Marusin, Lee <lee.marusin@fema.dhs.gov>; McCartney, Scott <Scott.Mccartney@fema.dhs.gov>; Kerschke, William <William.Kerschke@fema.dhs.gov>; Malone, Jack <Jack.Malone@fema.dhs.gov>; Johnson III, Lawrence <lawrence.johnsoniii@fema.dhs.gov>; GWIN Dan * OMD <dan.gwin@mil.state.or.us>
Subject: RE: DR4432/4452 - POBH: DREDGING projects #104046 & 110140

Thanks Jordan for update! we should have all the information ready, to include cost estimate to pre-disaster. I believe its all been uploaded into GP? Should we have a call to discuss?

From: Leigh, Jordan <jordan.leigh@fema.dhs.gov>
Sent: Tuesday, September 7, 2021 11:52 AM
To: Grant, Douglas <Douglas.Grant@fema.dhs.gov>

Cc: Michaels, Steven <Steven.Michaels@fema.dhs.gov>; Marusin, Lee <lee.marusin@fema.dhs.gov>; McCartney, Scott <Scott.Mccartney@fema.dhs.gov>; Kerschke, William <William.Kerschke@fema.dhs.gov>; Malone, Jack <Jack.Malone@fema.dhs.gov>; Johnson III, Lawrence <lawrence.johnsoniii@fema.dhs.gov>; SLEVIN Julie * OMD <julie.slevin@mil.state.or.us>; GWIN Dan * OMD <dan.gwin@mil.state.or.us>
Subject: RE: DR4432/4452 - POBH: DREDGING projects #104046 & 110140

Good morning,

We at the CRC have not received the versions for either projects yet in the CRC. We are unable to work a project until it reaches us at the CRC. My assumption is that both projects would need to be versioned, one to withdraw the A/E funding, and the other for validating the cost and writing up the project.

Please let me know if that is correct. In addition please let us know when we may see the versions at the CRC so we may begin working on them.

Thank you,

Jordan Leigh
Lane Manager | Consolidated Resource Center, West | Public Assistance Division
Mobile: (202) 856-5928
Jordan.Leigh@fema.dhs.gov

Federal Emergency Management Agency
fema.gov



FEMA

From: Grant, Douglas <Douglas.Grant@fema.dhs.gov>
Sent: Tuesday, September 7, 2021 10:56 AM
To: Leigh, Jordan <jordan.leigh@fema.dhs.gov>
Cc: Michaels, Steven <Steven.Michaels@fema.dhs.gov>; Marusin, Lee <lee.marusin@fema.dhs.gov>; McCartney, Scott <Scott.Mccartney@fema.dhs.gov>; Kerschke, William <William.Kerschke@fema.dhs.gov>; Malone, Jack <Jack.Malone@fema.dhs.gov>; Johnson III, Lawrence <lawrence.johnsoniii@fema.dhs.gov>; SLEVIN Julie * OMD <julie.slevin@mil.state.or.us>; Gwin, Dan <Dan.Gwin@state.or.us>; Gregory Jackson <gjackson@acdisaster.com>; Lucas Pagan <lpagan@acdisaster.com>
Subject: RE: DR4432/4452 - POBH: DREDGING projects #104046 & 110140
Importance: High

Good morning Jordan,

Earlier I left you a voice message inquiring about the progress on the cost validation of these merged projects. In this morning's daily huddle, Julie Slevin (State Public Assistance Officer) mentioned that the Applicant's Consulting Engineer, Jack Akin, had contacted her regarding the project status. She asked that Greg Jackson (State OEM rep) and I respond to Mr. Akin as soon as possible.

While Region 10 determines how the financial conditions are processed, the CRC cost estimate validation is underway as I understand your August 31st email, correct? Do you have an approximate timeline for concluding this step? Do your specialists need any additional information to continue? Would the R10 financial directives have to be in place before you can advance the project to the next steps? Thanks for updating the group. Doug

Douglas C Grant
PDMG – Public Assistance
DR4432OR
732-804-9239
Douglas.grant@fema.dhs.gov

From: Grant, Douglas
Sent: Tuesday, August 31, 2021 2:08 PM
To: Leigh, Jordan <jordan.leigh@fema.dhs.gov>
Cc: Michaels, Steven <Steven.Michaels@fema.dhs.gov>; Marusin, Lee <lee.marusin@fema.dhs.gov>; McCartney, Scott <Scott.Mccartney@fema.dhs.gov>; Kerschke, William <William.Kerschke@fema.dhs.gov>; Malone, Jack <Jack.Malone@fema.dhs.gov>; Ducote, David <david.ducote@fema.dhs.gov>; Ntagbu, Anthony <anthony.ntagbu@fema.dhs.gov>; Johnson III, Lawrence <lawrence.johnsoniii@fema.dhs.gov>
Subject: RE: DR4432/4452 - POBH: DREDGING projects #104046 & 110140

Jordan,

Thanks for the heads up. I'll request some input and direction from Steve; as we don't want this complex project to hit any approval snags once you finish developing it. DCG

Douglas C Grant
PDMG – Public Assistance
DR4432OR
732-804-9239
Douglas.grant@fema.dhs.gov

From: Leigh, Jordan <jordan.leigh@fema.dhs.gov>
Sent: Tuesday, August 31, 2021 1:47 PM
To: Grant, Douglas <Douglas.Grant@fema.dhs.gov>
Cc: Michaels, Steven <Steven.Michaels@fema.dhs.gov>; Marusin, Lee <lee.marusin@fema.dhs.gov>; McCartney, Scott <Scott.Mccartney@fema.dhs.gov>; Kerschke, William <William.Kerschke@fema.dhs.gov>; Malone, Jack <Jack.Malone@fema.dhs.gov>; Ducote, David <david.ducote@fema.dhs.gov>; Ntagbu, Anthony <anthony.ntagbu@fema.dhs.gov>; Johnson III, Lawrence <lawrence.johnsoniii@fema.dhs.gov>
Subject: RE: DR4432/4452 - POBH: DREDGING projects #104046 & 110140

Hi Doug, since I am not the Region I cannot determine if funding should remain or be de-obligated for the 4452 project. My recommendation would be to consolidate the two costs on 4432 since that is the project we are moving forward with. But again the Region would need to determine how they would like to handle the obligated funds.

Thank you,

Jordan Leigh
Lane Manager | Consolidated Resource Center, West | Public Assistance Division
Mobile: (202) 856-5928
Jordan.Leigh@fema.dhs.gov

Federal Emergency Management Agency
fema.gov



FEMA

From: Grant, Douglas <Douglas.Grant@fema.dhs.gov>
Sent: Tuesday, August 31, 2021 1:30 PM
To: Leigh, Jordan <jordan.leigh@fema.dhs.gov>
Cc: Michaels, Steven <Steven.Michaels@fema.dhs.gov>; Marusin, Lee <lee.marusin@fema.dhs.gov>; McCartney, Scott <Scott.Mccartney@fema.dhs.gov>; Kerschke, William <William.Kerschke@fema.dhs.gov>; Malone, Jack <Jack.Malone@fema.dhs.gov>; Ducote, David <david.ducote@fema.dhs.gov>; Ntagbu, Anthony <anthony.ntagbu@fema.dhs.gov>; Johnson III, Lawrence <lawrence.johnsoniii@fema.dhs.gov>
Subject: RE: DR4432/4452 - POBH: DREDGING projects #104046 & 110140

Hi Jordan,

It's been a couple of weeks already, so I thought I'd check in with you to see how the project merger is going. Since the original A&E projects have been obligated, I am not able to track the subsequent 'version' developments. Thanks for an update. Doug

Douglas C Grant
PDMG – Public Assistance
DR4432OR
732-804-9239
Douglas.grant@fema.dhs.gov

From: Grant, Douglas
Sent: Monday, August 16, 2021 3:31 PM
To: Leigh, Jordan <jordan.leigh@fema.dhs.gov>
Cc: Michaels, Steven <Steven.Michaels@fema.dhs.gov>; Marusin, Lee <lee.marusin@fema.dhs.gov>; McCartney, Scott <Scott.Mccartney@fema.dhs.gov>; Kerschke, William <William.Kerschke@fema.dhs.gov>; Malone, Jack <Jack.Malone@fema.dhs.gov>; Ducote, David <david.ducote@fema.dhs.gov>; Ntagbu, Anthony <anthony.ntagbu@fema.dhs.gov>
Subject: RE: DR4432/4452 - POBH: DREDGING projects #104046 & 110140

Many thanks, Jordan. Please let me know if I need to do anything within GM to have the DR4452 A&E costs withdrawn and reallocated to DR4432. Doug

Douglas C Grant
PDMG – Public Assistance
DR4432OR
732-804-9239
Douglas.grant@fema.dhs.gov

From: Leigh, Jordan <jordan.leigh@fema.dhs.gov>
Sent: Monday, August 16, 2021 3:18 PM
To: Grant, Douglas <Douglas.Grant@fema.dhs.gov>
Cc: Michaels, Steven <Steven.Michaels@fema.dhs.gov>; Marusin, Lee <lee.marusin@fema.dhs.gov>; McCartney, Scott <Scott.Mccartney@fema.dhs.gov>; Kerschke, William <William.Kerschke@fema.dhs.gov>; Malone, Jack <Jack.Malone@fema.dhs.gov>; Ducote, David <david.ducote@fema.dhs.gov>; Ntagbu, Anthony <anthony.ntagbu@fema.dhs.gov>
Subject: RE: DR4432/4452 - POBH: DREDGING projects #104046 & 110140

Good afternoon Doug,

We should be good to go on these projects. I spoke with our senior leadership. We should be able to capture the entire project costs on the one project in DR 4432, which will simplify the mitigation and scope. We will use project notes to reference the compounding damages.

I believe the remaining project under 4452 will need to have the A/E costs withdrawn and captured instead under the project on 4432.

Thank you,

Jordan Leigh
Lane Manager | Consolidated Resource Center, West | Public Assistance Division
Mobile: (202) 856-5928
Jordan.Leigh@fema.dhs.gov

Federal Emergency Management Agency
fema.gov



From: Grant, Douglas <Douglas.Grant@fema.dhs.gov>
Sent: Monday, August 16, 2021 3:06 PM
To: Leigh, Jordan <jordan.leigh@fema.dhs.gov>
Cc: Slevin, Julie <Julie.Slevin@state.or.us>; Gwin, Dan <Dan.Gwin@state.or.us>; Lucas Pagan <lpagan@acdisaster.com>; Gregory Jackson <gjackson@acdisaster.com>; Michaels, Steven <Steven.Michaels@fema.dhs.gov>; Marusin, Lee <lee.marusin@fema.dhs.gov>; McCartney, Scott <Scott.Mccartney@fema.dhs.gov>; Kerschke, William <William.Kerschke@fema.dhs.gov>; Malone, Jack <Jack.Malone@fema.dhs.gov>; Ducote, David <david.ducote@fema.dhs.gov>; Ntagbu, Anthony <anthony.ntagbu@fema.dhs.gov>
Subject: DR4432/4452 - POBH: DREDGING projects #104046 & 110140
Importance: High

Good afternoon Jordan,

Thanks for conferencing with Lee and me late last week, regarding the two above-referenced Port of Brookings Harbor dredging projects. Under the two initial A&E v0s, the Applicant's engineering design was completed and the Joint Permit Application (JPA) was submitted to the USACE. For detailed information, please refer to the design and permit documentation uploaded July 14, 2021 into Grants Manager under DR4432OR-project #104046 – Dredging. As we understand the process, the next step for the CRC would be to complete cost estimates to establish the Version 1s.

As discussed, per the full initial project descriptions, the two projects are not independent of each other, and the current design and permit documents reflect this. As well, the documents identify substantial mitigation measures needed to secure the repair works and prevent future similar disaster conditions. The State/Recipient has requested that we now combine the scope and costs of these into the one DR4432 project#104046, so that project recovery to pre-disaster conditions and 406 mitigation measures can be addressed in total. Due to the upcoming, short annual dredging allowable work window we are requesting the CRC to expedite the GM processes as much as possible so that hopefully, the EHP and Mitigation activities are concluded in time for the Applicant to initiate the dredging operations early this Fall [note: this window is only from October 2021 thru March 2022].

Thanks for undertaking the next steps towards finalization of the comprehensive project. Please let us know if we need to provide any additional information or documentation. Doug

Douglas C Grant
PDMG – Public Assistance
DR4432OR
732-804-9239
Douglas.grant@fema.dhs.gov



EMC

Grants Pass * Jacksonville * Medford, OR

GP Office: 1867 Williams Hwy., Suite 216, Grants Pass, OR, 97527

Jville Office: 450 Conestoga Dr., Jacksonville, OR, 97530

Ph: 541-474-9434 * Cell: 541-261-9929 * Fax 541-727-5488

emc@emcengineersscientists.com; <http://www.emcengineersscientists.com>

- Engineers/Scientists, LLC

5/16/21

Gary Dehlinger
Port Manager
Port of Brookings Harbor
Brookings, OR 97477

Scope of Work for FEMA 4432, 4452

PA-10-OR-4432

Title 104046-Dredging, Application No. PA-10-OR-4432 (4432) is assigned a period of performance beginning May 2, 2019. The Subgrant Application proposes to repair damages as a result of the February 23rd – 26th severe storms that engendered landslides and deposited debris throughout the Port of Brookings Harbor, and included the shallowing of key marine vessel moorage, the destabilization of embankments (particularly along the West Basin 2 wall), and the accumulation of sediment beneath docks near the west embankment of Basin 2.

The sediment accumulating beneath the docks caused them to rest on the mudline beneath during low tides, causing damage to the docks. Landslides that occurred during the storm along the Basin 2 west embankment covered previously existing riprap along areas identified as Sites 1, 2 and 3, and revealed previously buried riprap in areas along embankment between these three sites. 4432 as it was proposed was purposed to remove sediment that had accumulated from the storm. The sediment volumes, about 7500 yd.³ in Basin 2 and 500 yd.³ in Basin 1, were estimated from comparisons of recent, sequential bathymetric surveys. Sediment migrated into identified areas of the Port basins via wild fire-generated material from the Chetco River, overtopping stormwater along the south and west embankments in Basin 2 and along the west and north Ice House Inlet embankments, and from pore water from the embankment walls themselves.

Connection with Application Title: 110140 - Port Dredging, Application Number: PA-10-OR-4452

Noted in the Special Notes of the 4432 Application is that the sediment issues and solutions associated with 4452 are inextricably connected to those of 4432.

Engineering determinations, including comparative bathymetric surveys, found that about 15,500 yd.³ of sand/soil/mud debris had accumulated in Basin 1, and about 12,500 yd.³ of the same accumulated in Basin 2 as a result of the April, 2019 storm.



Grants Pass * Jacksonville * Medford, OR

GP Office: 1867 Williams Hwy., Suite 216, Grants Pass, OR, 97527

Jville Office: 450 Conestoga Dr., Jacksonville, OR, 97530

Ph: 541-474-9434 * Cell: 541-261-9929 * Fax 541-727-5488

emc@emcengineersscientists.com; <http://www.emcengineersscientists.com>

- Engineers/Scientists, LLC

These two events were back to back and overlapping with respect to hydrographic data, as it would be noted that the rising limb of the April flows would overlap the falling limb of February flows, creating a “one- two punch” on vulnerable Port locations, so that the second event in April, 2019 created more damage than the first event in February.

Completing these two projects (4432 and 4452) as one provides not only logical, but economic benefit, in that the duplication of engineering, permitting and mobilization/demobilization of equipment required for both of these projects, as well as for any proposed mitigation actions, can be averted.

As it now stands, these two projects have each been separated by FEMA into two subprojects, (Phase 1 and Phase 2) the first of which is the engineering and permitting functions necessary to assess, design and permit both 4432 and 4452. \$39,600 was assigned to 4432 and \$80,400 was assigned to 4452 for the engineering/permitting Phase.

The two projects (4432 and 4452) would be accomplished simultaneously, saving several hundred thousand dollars. Thereby the preliminary estimated cost for dredging the 38,000 yd.³ is \$1,770,000. .

The Work Orders 47755 and 45060 were filled and submitted by the Port describe the dredge volumes with attached bathymetric and engineering documentation, provided after the 9/20/2019 FEMA Site Inspection.

Engineering estimates place the budget close to the original at **\$1,790,000**, as itemized in the attached **EXHIBIT A – Dredging**.

Damage #304676; Basin 2 - Slope Failure and Scope of Work

The severe storm deposited a mixture of sand/soil/mud within the harbor. The debris caused a loss of soil cohesion in the slopes and steep embankments of the Harbor. Previously buried toe slabs and rocks meant to armor and help support the steep overlying embankment are now revealed, particularly along the west side of Basin 2.

Cause of Damage: The severe storm deposited a mixture of sand/soil/mud within the harbor. The debris caused a loss of soil cohesion in the slopes and steep embankments of the Harbor. Previously buried toe slabs and rocks meant to armor and help support the steep overlying embankment are now revealed, particularly along the west side of Basin 2. The erosive mechanism is described in more detail below in the section named **Storm and Erosion Processes**.



Grants Pass * Jacksonville * Medford, OR

GP Office: 1867 Williams Hwy., Suite 216, Grants Pass, OR, 97527

Jville Office: 450 Conestoga Dr., Jacksonville, OR, 97530

Ph: 541-474-9434 * Cell: 541-261-9929 * Fax 541-727-5488

emc@emcengineersscientists.com; <http://www.emcengineersscientists.com>

- Engineers/Scientists, LLC

Damage Description: Primary damages to Port embankments from 4432 and 4452 Disasters were observed and have been recorded in Basin 2, the south basin of the Port of Brookings Harbor. Generally, riprap repair is the most economical repair method for these slopes.

On the 2 East Slope, 542 CY of unclassified mixed riprap, 195 FT long x 5 FT wide x 15 FT deep would be required.

On the South Slope, 578 CY of unclassified mixed riprap, 208 FT long x 5 FT wide x 15 FT deep would be required.

On the Transient Slope, 289 CY of unclassified mixed riprap, 104 FT long x 5 FT wide x 15 FT deep would be required.

On the Basin 2 West Slope, 502 CY of unclassified mixed riprap, 452 FT long x 5 FT wide x 6 FT deep would be required.

The measurements for the embankment are based on applicant provided engineering information.

The unitized engineering budget for the riprap repair is **\$675,157**, as itemized on **EXHIBIT A - Slope Repairs**.

The scope of work for Slope Repairs is herein proposed to be revised, replacing partial and therefore vulnerable small repair slopes, some of which (east and transient) are more stable and of lower priority, with the recommended, continuous repair of the west and south slopes of Basin 2. Volumes of riprap needed remain unchanged.

The unitized total engineering budget for the revised scope of work is presented on the attached **Exhibit A - FEMA Repairs** to pre-disaster Conditions is therefore **\$2,465,157**. The engineered drawings showing the Slope Repairs are attached as files named **Slope Repairs DWG - West Basin 2 Wall**, and **Slope Repairs DWG - South Basin 2 Wall**.

Proposed Lower Cost Dredging Alternative, and Scope of Work

A Feasibility Study was produced for the Port of Brookings Harbor, investigating dredging alternatives. The Study was summarized in a PowerPoint Presentation to the Port of Brookings Harbor Staff and Board of Commissioners. A trimmed version to reduce file size) of the Presentation, with videos, disposal, case study, maintenance and permitting requirements removed, is attached as **EXHIBIT D**.



Grants Pass * Jacksonville * Medford, OR

GP Office: 1867 Williams Hwy., Suite 216, Grants Pass, OR, 97527

Jville Office: 450 Conestoga Dr., Jacksonville, OR, 97530

Ph: 541-474-9434 * Cell: 541-261-9929 * Fax 541-727-5488

emc@emcengineersscientists.com; <http://www.emcengineersscientists.com>

- Engineers/Scientists, LLC

The Study was generated by the growing concerns about sedimentation in the harbor that is being accelerated by Chetco wildfire erosion. The Study investigated the feasibility of implementing an in-house maintenance dredging program and operation at the Port, in comparison to other dredging alternatives. The analyses included barge and scow, hydraulic suction dredging, mechanical, or clamshell dredging; disposing of sediments upland via storage piling on land, or other out-of-water beneficial or non-beneficial uses such as trucking to a more distant disposal area (e.g. landfill or private property), in-water, including ocean disposal, beach nourishment, flow-lane and tidal/intertidal storage, all evaluated via data and experience.

A continuous reduction in the availability of safe moorage due to shoaling is occurring at the Port. In order to focus on solutions that make sense, a these options were considered in the Study. Some have been reviewed in the past and have been determined to be too expensive, cumbersome and/or unpredictable. Overall budgetary constraints, primarily caused by high dredging costs, limit the Port's ability to maintain its moorage. Funds for necessary paving and stormwater control that would otherwise be implemented to protect the duration of the Port embankment repairs have instead been allocated to the maintenance of navigable depths.

In order to construct a more permanent hardening of these embankments, and to provide remedy against future predicted sediment flows generated by the Chetco wildfires, the Port presents an alternative that could assist the Port to respond, not only to sediment from the 2019 disasters, but also to increasing sediment, already observed (see attached **EXHIBIT E**) shoaling increases.

The dredging costs for this lower cost alternative is **\$1,192,174**, reduced \$597,826 from that of the original dredging method proposed.

This alternative, additional to the estimated savings, reduces the Port's vulnerability to damages from future, predicted shoaling. Budget details for the Lower Cost Alternative are presented in the attached **EXHIBIT B**. Note that the Total Project cost in **EXHIBIT B** of **\$1,717,331** includes the **\$675,157** for Slope Repair.

Preliminary drawings showing the proposed Lower Cost Alternative, are attached, files entitled **Sediment Storage - Proposed Dredging Alternative DWGS** and **Equipment Storage-Proposed Dredging Alternative DWGS**, which show the proposed Scopes of Work.

Public Assistance 406 Mitigation Funding Request, and Scope of Work

The Port proposes that the Public Assistance Program and Policy Guidelines (V3.1), Appendix J, 1.B, enlists the mitigation of the erosion threat to be cost effective, as described below. 100% of the Total Repairs budget for 4432 (**\$949,464**) and 100% of the Total Repairs budget for 4452 (**\$917867**).



Grants Pass * Jacksonville * Medford, OR

GP Office: 1867 Williams Hwy., Suite 216, Grants Pass, OR, 97527

Jville Office: 450 Conestoga Dr., Jacksonville, OR, 97530

Ph: 541-474-9434 * Cell: 541-261-9929 * Fax 541-727-5488

emc@emcengineersscientists.com; <http://www.emcengineersscientists.com>

- Engineers/Scientists, LLC

The mitigation funding would be used in part to extend paving from the Sediment Storage access road and work area in the Commercial Area, shown in the drawings with file name **Sediment Storage - Proposed Dredging Alternative DWGS**, southward to the presently unprotected embankments adjacent to the commercial receiving docks and Ice House Inlet, shown in the drawings with file name **Mitigation of Paving to Commercial Embankments DWGs**.

The mitigation funding would also be used in part to extend paving from the Equipment Storage access and work area in the Boatyard, shown in the drawings with file name **Equipment Storage-Proposed Dredging Alternative DWGS**, north and westward to the presently unprotected embankments adjacent to the Boatyard which is the south Basin 2 wall, shown in the drawings with file name **Mitigation of Paving to Boatyard Embankments DWGs**.

The last portion of mitigation funding would be used to protect the wesin part to extend paving from the Equipment Storage access and work area in the Boatyard, shown in the drawings with file name **Equipment Storage-Proposed Dredging Alternative DWGS**, north and westward to the presently unprotected embankments adjacent to the Boatyard which is the west wall of Basin 2, and the most impacted embankment at the Port. This proposed project shown in the drawings with file name **Mitigation of Paving to Basin 2 West Embankment DWGs**.

Although it can be seen that an intended use for this pavement is as an RV area, it is herein underscored that no infrastructure (buildings, water lines, electric service, sewer lines or connections, etc.) are included in this budget. The paving shown will effectively cut off surface stormwater flows, and intercept 85% of the water seeping into permeable soils.

The Need for Proposed Mitigation

It is evident that three recurring factors (1. Existing unstable embankments; 2. High winds and severe winter storms and 3. Increased erosion and sediment migration do to the Chetco wildfires) will continue to degrade and block future Port operations. The recurrence of these factors is documented by, among other events and repairs, FEMA repairs that have occurred at the Port of Brookings Harbor in the last 10 or 11 years. These recurrences have been presented in the Benefit/Cost Analyses, produced within the framework of Version 6.0.0 of Build 20200819-1933, attached as **EXHIBIT F**. The following analyses the erosion processes occurring along the south and west embankments of Basin 2, and the exposed embankments adjacent to the commercial receiving docks and Ice House Inlet.



Grants Pass * Jacksonville * Medford, OR

GP Office: 1867 Williams Hwy., Suite 216, Grants Pass, OR, 97527

Jville Office: 450 Conestoga Dr., Jacksonville, OR, 97530

Ph: 541-474-9434 * Cell: 541-261-9929 * Fax 541-727-5488

emc@emcengineersscientists.com; <http://www.emcengineersscientists.com>

- Engineers/Scientists, LLC

Storm and Erosion Processes

Contributing factors to embankment failure and subsequent sediment accumulation, and associated Port dock damages, are high winds and storm-generated erosion from embankment overtopping (stormwater flows that combine into streams and flow over the top of embankments, scoring and weakening the grade) and pore water (water seeping into permeable landings and, via hydraulic head, breaking through side banks, accelerating embankment erosion. Paving these landings and controlling stormwater flows along the west and south Basin 2 walls, and the Ice House Inlet commercial areas, would provide permanent protection to the Port.

Stormwater Flow Volumes

Rainfall at the Port of Brookings Harbor averages 83.5 inches/year, 2.2 times the national average. Of the 106.2 days in a given year that rain falls at the Port, nearly falls between late September and early to mid-April of each year. An affected landing zone of 50 – 100' in width, borders the Port Basin shorelines. This margin covers a footprint of about 734,500 ft.².

Along that total area about 117.34 acre feet (5,111,473 ft.³) of rain water flows over or infiltrates along the approximately 5800 foot long Port Basin shoreline.

Affected and Relatively Non-affected Embankments

The margin areas along the embankments of the north and east of Basin 1 are paved, and the stormwater in those areas is controlled by catch basin and piping systems. On the west side of Basin 1 is a heavy riprap jetty. A couple hundred feet of the north end of the west Basin 2 landings are also paved and stormwater is similarly managed, as that area is occupied by the US Coast Guard. Much of the landing area approaching the Boatyard on the east side of Basin 2 has been paved and is equipped with stormwater catch basins and piping. The landing area margin above and including the fueling supply and Fuel Dock have recently been paved, and catch basins and piping installed.

This was done because of the recent failure of the Dock Access Pad, which was falling westward into Basin 2, due to the same erosive mechanisms described in this section. The concrete pad was removed, the area above the pad embankment (about 1300 ft²) was paved and two catch basins and connecting underground piping placed.

Most of the approaching landing between the Fuel Dock area and the Boatyard area along the east side of Basin 2 are more gradually sloped and erosion due to stormwater infiltration and overtopping are of much less concern to the Port.

Concerns with respect to accelerated erosion therefore remain at Port Basin shorelines surrounding the Commercial Receiving Dock areas, the Icehouse Inlet and the Basin 2 south and west embankments.



Grants Pass * Jacksonville * Medford, OR

GP Office: 1867 Williams Hwy., Suite 216, Grants Pass, OR, 97527

Jville Office: 450 Conestoga Dr., Jacksonville, OR, 97530

Ph: 541-474-9434 * Cell: 541-261-9929 * Fax 541-727-5488

emc@emcengineersscientists.com; <http://www.emcengineersscientists.com>

- Engineers/Scientists, LLC

Accelerated erosion from stormwater overtopping and infiltrating the Commercial Receiving Dock and Icehouse Inlet areas are not directly attributable to the 2019 February and April damages (4432 and 4452), but are caused by the erosive mechanisms described in this section.

Damage Process

Existing riprap has been buried or unraveled, and embankment cave-ins have, as a result of these two back-to-back events, occurred and continue to occur along the approximate 1300 linear feet of exposed embankment along the south and west Basin 2 walls.

The average soil permeability coefficients (using C.I.A. ground surface classifications) of the landings approaching these embankments is about 0.4, and so approximately 40% precipitation on the landings affecting these embankments (about 352.5 ft.³ /linear foot/season) sinks into the ground and joins the high groundwater flows during storm season, found by average piezometric data to be at about 8 foot below ground surfaces.

This excess water works its way by pore pressure (8 feet head or greater) at elevations of 8 to 10 feet from top of bank and erodes the base material along these embankments. The remaining 60 percent (about 529 ft.³ /per linear foot/season) overtop the embankment on these unpaved areas, scoring and weakening the embankment structure.

The above would not be enough data to guide remediative design, unless augmented by duration data. This data is available via the Rainfall Intensity-Duration-Recurrence Interval (RDI) Curves (these can be obtained from the ODOT Manual, Appendix A, Zone 1).

There it can be seen that rainfall often occurs in the area with RDI coefficients of 1 for about 60 minutes, and as high as 4 for five minute intervals. Such coefficients, using classical stormwater flow calculations result in 4 to 16 cubic feet per second over the embankments for durations ranging from 5 minutes to an hour. The narrow margin lengths mean that concentration times are nearly instantaneous. This data represents a small winter storm at the Port. Major storms, such as the ones that occurred in April, 2019, last for days, with stormwater flows that range as described. High embankments of non-cohesive soils (sand) that are margined with permeable soils are not well protected against such stormwater flows, often driven by high (60 – 100 mph) winds.

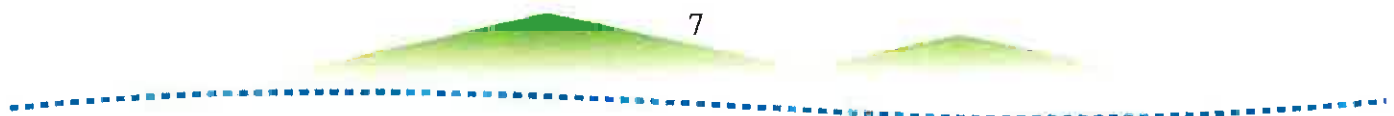



Grants Pass * Jacksonville * Medford, OR

GP Office: 1867 Williams Hwy., Suite 216, Grants Pass, OR, 97527

Jville Office: 450 Conestoga Dr., Jacksonville, OR, 97530

Ph: 541-474-9434 * Cell: 541-261-9929 * Fax 541-727-5488

emc@emcengineersscientists.com; <http://www.emcengineersscientists.com>

- Engineers/Scientists, LLC

Stormwater Contamination

On a side note, natural, commercial and industrial releases of state and federally regulated hazardous constituents have, via stormwater sampling and laboratory analysis, been found to be carried to measured monitored stormwater outfalls during winter storm events.

Engineering and Port management investigations have concluded that containment and encapsulation of landings and presently eroding surfaces, and embankment stabilization, as provided by stormwater catch basin/piping and paving, would not only permanently stabilize slopes and harden the Port's infrastructure against overtopping and pore water erosion, but would also provide the added benefit of protecting the public health and environment, including ESA-listed species, from excessive contamination from regulated substances.

All stormwater data reports (DMRs) showing the exceedances are available upon request.

Therefore the proposed mitigation would provide the additional benefit to effectively reduce soil-borne contaminants presently being released into the waters of the US/State.

Sincerely

Jack (John) Akin, MS, PE, IC, HMS, CAI
EMC-Engineers/Scientists, LLC

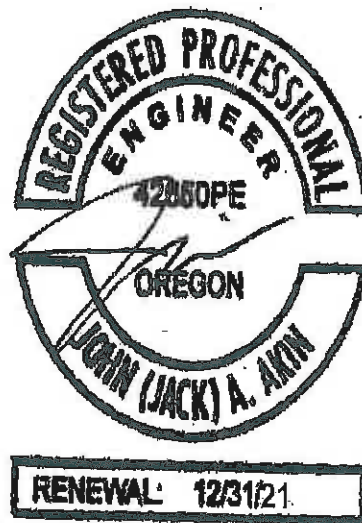

EXHIBIT A - FEMA 4432 AND 4452 REPAIRS

Dredging	Equipment Mobe/Demobe, and Settling Basin	Trucking and Disposal \$/cy	Hydraulic Dredging, \$/cy	Volume in cy	Pipe Cost, 10 SDR 21 HDPE, 3000 ft. \$14/ft	Dredging Costs
FEMA 4432	190,000	25	16	8,000	42000	560000
FEMA 4452	0	25	16	30,000	0	1230000
TOTAL BUDGET						1790000

Slope Repairs	LS Equipment Mobe/Demobe	\$/sf Excavation, Erosion Control	\$/cy Move, Mix, Place, Compact	\$/cy Purchase & Deliver Riprap	\$/cy Place Riprap	Fabric \$/sf
All Slopes- #304676	65000	2.25	97	102	35	0.65
\$/cy Base Rock Purchase, Delivery and Placement	Volume of Base Rock, cy	Area of Erosion Controlled, sf	Volume Soil/cy	Volume Riprap cy	Area Fabric, sf	
140	1010	28700	1250	1911	32500	
Excavation and Erosion Control Total	Move, Mix and Compact Total	Riprap Purchase and Deliver Total	Riprap Placement Total	Fabric Total	Base Rock Total	TOTAL BUDGET
64575	121250	194922	66885	21125	141400	675157

Engineering/Permitting	Slope Repairs Total	Dredging Total	PROJECT TOTAL
120000	675157	1790000	2465157

EXHIBIT B - FEMA 4432 AND 4452 REPAIRS, Lower Cost Alternative

Dredging	120 HP Electric Dredge, Training, Shipping	Trailer-Mounted Generator, Shipped	3000 ft. 8" Dia. HDPE Pipe, \$4/ft.	Volume in cy	LABOR: per 300 cy/dy, 2600 labor-hrs total reqd, @ \$20/hr	Dredging Costs
FEMA 4432	230,000	60000	12000	8,000	11,200	321,200
FEMA 4452	0	0	0	30,000	42000	72,000
Totals						393200
Access & Work Areas	Coverage, sf	\$/cy Excavation, Grading	\$/sf Subgrade Compaction	\$/cy Mixed Aggregate for Subbase, placed and compacted	\$/Ton Asphalt, Placed	\$/cy Concrete
Sediment Storage	37250	20	0.5	50	125	130
Equipment Storage	10750	20	0.5	50	125	130
\$/Specified Catch Basin, ea	\$/ft Curb & Gutter, Labor	Cur/Fill Volumes, cy	Volume of Sub-base and Base Rock, cy	Volume of Asphalt, Tons, 3" Thick	Length of Curb & Gutter, ft	12" SW Pipe Installed/ft.
3000	32	3290	1150	745	1911	25
3000	32	600	332	215	65	25
SW Pipe Length, ft	No. Catch Basins	SW System Total	Grading Total	Sub-Grade Compaction Total	Aggregate Total	Asphalt Total
800	4	32000	65800	18625	57485	93125
100	1	5500	12000	5375	16590	26875
Curb & Gutter Total	\$/sf Sediment Storage Wall, with footing	Sediment Storage Wall Area (L X 3' H), sf	Sediment Storage Wall Total	16' X 16' X 45' Prefab Equipment Storage Bldg, Steel	Engineering & Permitting	Riprap Wall (See EXHIBIT A)
72629	30	3300	99000	0	39,600	0
2470	30	0	0	21500	80,400	675157
Repair of Damaged Sidewalk from West & South Wall Excavations	PROJECTS	TOTAL BUDGET	TOTAL REPAIRS-LOWER COST ALTERNATIVE		1867331	
150000	FEMA 4432	949464				
	FEMA 4452	917867				

EXHIBIT C - FEMA 4432/4452 MITIGATION, Assuming Implementation of the Lower Cost Alternative

Access & Work Areas	Coverage, sf	\$/cy Excavation, Grading	\$/sf Subgrade Compaction	\$/cy Mixed Aggregate for Subbase, placed and compacted	\$/Ton Asphalt, Placed	\$/cy Concrete
Commercial Area	101815	20	0.5	50	125	130
Boatyard	93750	20	0.5	50	125	130
Kite Field RV Area	100200	20	0.5	50	125	130
\$/Specified Catch Basin, ea	\$/ft Curb & Gutter, Labor	Cut/Fill Volumes, cy	Volume of Sub-base and Base Rock, cy	Volume of Asphalt, Tons, 3" Thick	Length of Curb & Gutter, ft	12" SW Pipe Installed/ft.
3000	32	12800	3142	2036	1100	25
3000	32	2500	2894	1875	1200	25
3000	32	11333	887	575	1500	25
SW Pipe Length, ft	No. Catch Basins	SW System Total	Grading Total	Sub-Grade Compaction Total	Aggregate Total	Asphalt Total
3200	5	95000	256000	50908	157122	254538
1500	4	49500	50000	46875	144676	234375
1500	4	49500	226660	50100	84367	71875
Curb & Gutter Total	TOTAL BUDGET	PROJECTS	\$ Mitigation			
41807	855374	4432	1110544	TOTAL BUDGET FOR PROPOSED MITIGATION, ADDITIONAL TO TOTAL REPAIRS		
45607	571033	4452	855374			1965918
57009	539511					
TOTAL BUDGET FOR PROPOSED REPAIRS, AND FEDERAL/STATE MITIGATION		3,833,249	HMGP Request	406,4432		406,4452
			98,587	Mitigation	949464	917867
			4452-HMGP	Repair	949464	917867
			1,934,321	TOTAL/Project	1898928	1835734
				TOTAL	3734662	

— INTENTIONALLY BLANK —

EXHIBIT D – POWER POINT PRESENTATION

(Videos and Other Sections Removed)

A Feasibility Study Was Done for the Port

IN-HOUSE DREDGING: FEASIBILITY STUDY

By Jack Akin, MS, PE, IC, HMS, AI

For

**Port of Brookings Harbor
Gary Dehlinger, Port Manager
Travis Webster, Harbormaster**

In Summary

This study investigated the feasibility of implementing an in-house maintenance dredging program and operation at the Port, in comparison to other dredging alternatives.

A continuous reduction in the availability of safe moorage due to shoaling is occurring at the Port. In order to focus on solutions that make sense, a number of options have been considered in the Study. Some of these options have been reviewed in the past and have been determined to be too expensive, cumbersome and/or unpredictable.

Barge and scow, hydraulic suction dredging, mechanical, or clamshell dredging; disposing of sediments upland via storage piling on land, beach nourishment, or other out-of-water beneficial or non-beneficial uses, trucking to a more distant disposal area (e.g. landfill or private property), or in-water, including ocean disposal, beach nourishment, flow-lane and tidal/intertidal storage were evaluated via data and experience.

For the purposes of comparison these dredging and disposal options use a volume of 25,000 cubic yards of sediment.

Barge and scow dredging has been found to be both expensive and impractical, primarily due to considerations of navigability and availability. The standard barge may be as large as 200-foot long and 50-foot wide, with a 12-deep scow. Such a barge would be outfitted with appropriate duty spuds for anchoring and stability once it is in the desired location. The spuds on the barge must be of sufficient length allowing it to anchor itself in harbor depth of water. Out of the USACE's most recent abstract of offers for the barge and scow dredging of several port locations nearby, mobilization and demobilization alone, depending upon the selected sediment placement location, varies in the cited bid from \$477,211 to about \$756,250. Dredging/disposal per cubic yard was bid competitively, based on the large total volume of sediment to be dredged for this multi-locational project.

During third quarter 2019, for example, while McAmis, a barge and scow USACE winning subcontractor, was fulfilling their contract with the USACE at Winchester Bay, they accepted an offer from Salmon Harbor Marina to add to their federally contracted work by “piggybacking” the Marina’s work. A \$21/cubic yard charge was proposed to the Marina, rather than the \$11 or \$12/ cubic yard offered to the USACE as part of the federal project. The Marina would have had to pay hundreds of thousands of dollars to mobilize such equipment for themselves, unless they were able to gain agreement to “piggyback” as described. The cost to dredge 25,000 cubic yards, if “piggybacking” was available, is therefore estimated at the Port of Brookings Harbor to be \$525,000, and, if “piggybacking” was not available, at best, \$777,000 (\$12/cy + \$477,000 moke/demobe). However, many areas requiring dredging in Basins 1 and 2 would not be accessible via this equipment.

Hydraulic suction dredging utilizing contracting standard swing-ladder dredges has been seen to be a viable method at the Port, but comes with high mobe/demobe costs, and does not lend itself to in-house maintenance dredging at smaller ports and marinas. Mobe/demobe costs to and from nearby locations have been seen to range from \$40,000 to \$55,000. Dredging costs additional to mobe/demobe have been found to range from \$20 to \$35/cubic yard, if sediment is disposed to nearby in-water or upland locations.

However, without development, no nearby in-water or upland disposal locations are available for the Port, and so the only other alternative is that of ocean disposal.

A number of analytical routines have been done for the Port, including selection of an appropriate pipe diameter (14" OD), determination of the required DR or SDR (17 SDR HDPE), determination of the required weighting, and of the design, construction and spacing of ballast weights, buoyant force, weight of pipe and pipe contents, methods of installation, preparation of land-to-water transition zones and, when required, underwater bedding, assembly of individual lengths of pipe into long continuous lengths, launching of pipeline into water, bending radius at which buckling can be initiated, etc. The higher sediment slurry velocities required in long pipelines to prevent clogging result in higher total dynamic head (TDH).

Combinations of pipe thicknesses necessary to resist the high total dynamic head (TDH) created by slurry traveling through 12,000 foot pipe lines at the recommended velocity are not found to be available for reasonably sized dredges, and so, booster pumping would be required.

Additional to the complexities associated with pumping slurry such long distances are those presented by the challenging task of working with a pipeline placed through river and ocean currents, whether floating or sunken. EMC has estimated designed and provided project engineering for ocean disposal and estimates the cost for such a project (25,000 cubic yards to the ocean disposal location via pipeline) from the Port to be \$980,000.

Disposal Limitations

1. Available ocean disposal location is about 12000 feet from the furthest Port reach.
2. Hydraulic suction dredges small enough to navigate throughout the Port docks would be equipped with pump horsepower not sufficient to pump that distance, without at least one in-line booster pump. Potential pipeline pathways require a combination of land and water routes unfriendly to a successful dredging operation during winter weather.
3. USACE has determined in the past that the Chetco River reach and entrance are not approached with enough river flow energy to deliver flow-lane sediments beyond the federal channel.
4. No nearby in-water storage areas are permitted to be used by the Port.

5. When considering upland storage during a dredging event at the Port, it must be taken into account that any possible storage and de-watering area within the Port limits sediment volumes during a single event to 25,000 cubic yards, and reasonable volumes of 6 – 8000. Therefore, use of a large dredge for upland disposal at the Port would require multiple events and subsequently multiple move/demove costs, rendering this option infeasible.

6. Likewise, to utilize barge and scow for upland storage at the Port would present the Port, in addition to multiple handling of the sediment for placement, the same volume limitations and associated multiple move/demove costs.

So this Study concludes that a low cost, in-house dredging operation would bring many advantages to the Port. Flexibility and rapid response to ongoing mooring challenges would bring a level of internal control not often experienced at small ports in Southern Oregon. During our review of practicable alternatives, we concluded that a smaller and more mobile dredging unit could provide the required navigability, and in-house control, that would be affordable and be more able to provide the Port with long-term maintenance dredging.

It is also concluded that annual maintenance dredging volume requirements at the Port are relatively small, because the major portion of shoaled sediments from Port facilities slough to federally maintained channels, and so a modest maintenance program, on an annual basis, could maintain the Port mooring spaces, and additionally could enable the Port to gradually and affordably reduce its backlog, which has been accumulating over decades.

The above conclusions bring us to the analyses of in-house operational scenarios, utilizing small, maneuverable dredges, and local, perhaps even beneficial sediment disposal options.

EMC in the past has specified portable, centrifugal pump-driven slurry pumps, well fitted for the dredging of dock locations (e.g. Port of Port Orford).

So equipment provided by BPH, Eddy, DragFlow and TOYO Pumps were analyzed and compared.

After considering economic value, equipment design, horsepower, maneuverability, etc., EMC recommends that the Port consider an in-house, small dredge system, utilizing the DragFlow DPR-120 remote controlled dredge, rigged with the EL 1204HH C Model pump system.

Slides and video clips focus on this equipment, its applicability, function and maintenance. We will also briefly review the proposed upland disposal option, permitting requirements and costs associated with this recommended in-house dredging option.

Dredge Details:

1. Control Panel
2. Dredging pump
3. Electric Hoist
4. 4 Winches (45 – 110m)
5. Jet Ring System for breaking the material to be dredged

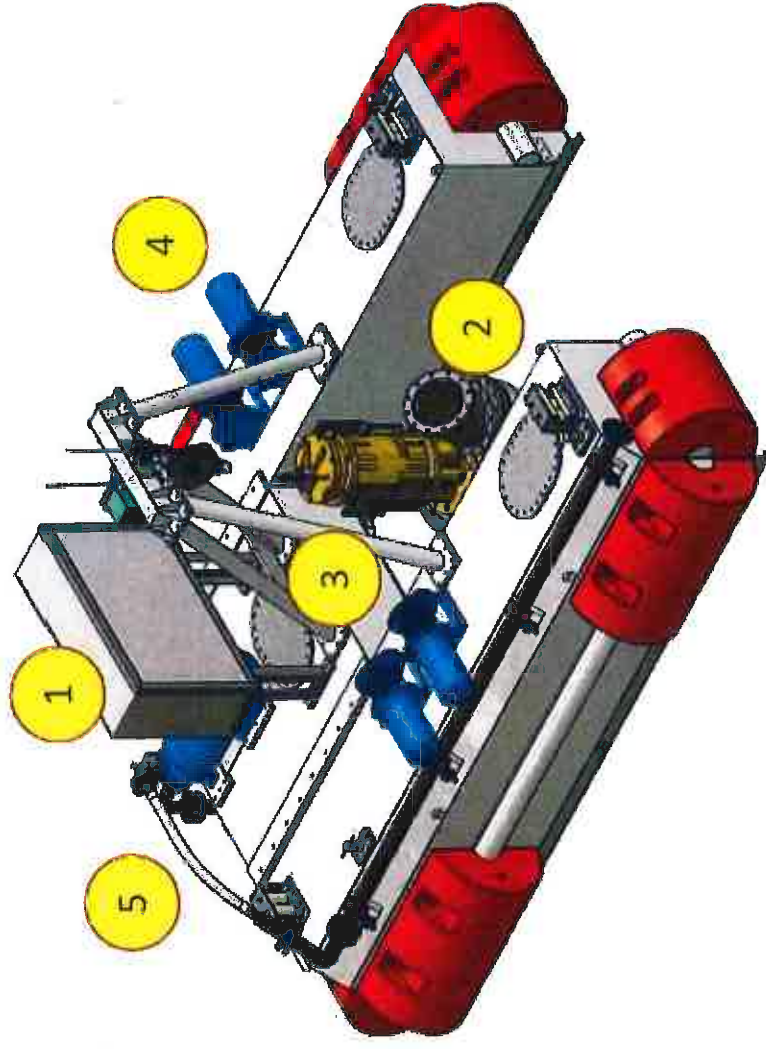

DRAGFLOW

ULTIMATE EFFICIENCY

%	25
%	40
d50 > 15 mm	1
kg/dm ³	2
kg/dm ³	1.25
Pa s	0.001

Mixture Details
 Solids concentration in the mixture
 % by volume
 % by weight
 Solid Particles Dimension
 Particle Median Diameter
 Liquid SG
 Solids SG
 Mixture Specific Gravity
 Fluid dynamic Viscosity

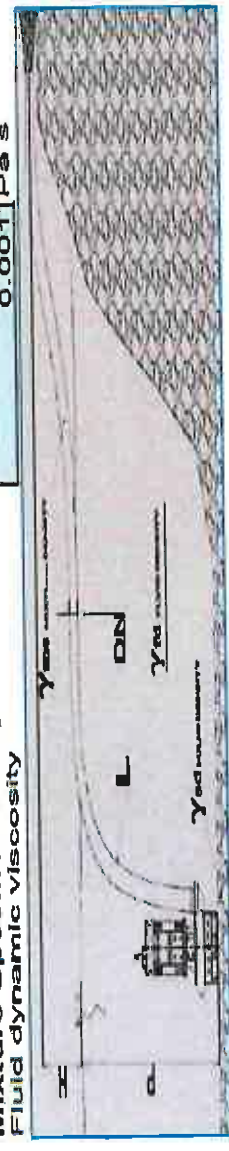

1.2	m
15.2	m
914.4	mm
198.2	mm
273	m ³ /h

Application Details
 Geodetic Height (Air) = H
 Geodetic Height (Water) = P
 Pipeline Total Length = L
 Pipe Internal Diameter = DN
Total Mixture Capacity

4	ft
50	ft
3000	inch
7.803	inch
1200	GPM

35.3	m
0.5	m
5.0	m
40.8	m
2.5	m/s

System TDH at set capacity
 Friction loss along the pipeline
 Concentrated pressure drops
 Geodetic: [H+(mixSG-liqSG)*P]
 Total Dynamic Head (TDH)
 Mixture velocity inside the pipeline

115.7	ft
1.5	ft
16.5	ft
133.7	ft
8.0	ft/s

100	HP
120	HP

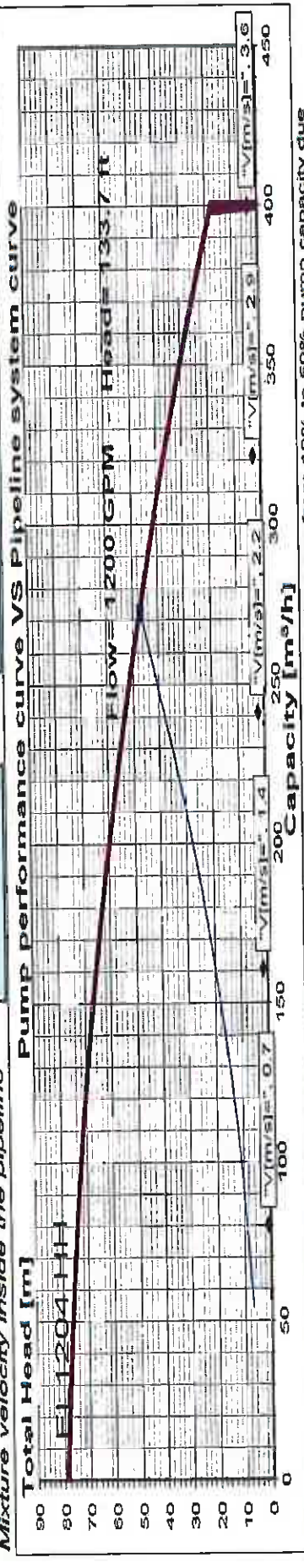

* All the above values come from theoretical calculations. The solid concentration can vary from 10% to 50% pump capacity due

Port of Brookings-Harbor
Calculation Sheet For 6" and 8" SDR 21 Pipeline, 120 hp
 by Jack Akim, MS, PE

Q_{open}	1098.00	1200.00	3000.00	1000.00	1720.00	3000.00
CHW	155.00	155.00	155.00	155.00	155.00	155.00
L _n	3000.00	3000.00	3000.00	3000.00	3000.00	3000.00
d_{in}^3	5.96	5.96	5.96	7.75	7.75	7.75
Q_{in}^3	2.45	2.67	6.68	2.23	3.83	6.68
V_{in}^3	12.65	13.82	34.55	6.80	11.69	20.39
c _n	5.00E-06	5.00E-06	5.00E-06	5.00E-06	5.00E-06	5.00E-06
v_{50}^3	1.45E-05	1.45E-05	1.45E-05	1.45E-05	1.45E-05	1.45E-05
R_c	4.34E+05	4.74E+05	1.19E+06	3.04E+05	5.22E+05	9.11E+05
e/D _n	1.01E-05	1.01E-05	1.01E-05	7.74E-06	7.74E-06	7.74E-06
$R_{e.5}$	1.18E+05	1.28E+05	2.93E+05	8.59E+04	1.40E+05	2.31E+05
F Logic Precalc	-4.29	-4.32	-4.65	-4.16	-4.37	-4.57
Square of Previous	18.41	18.70	21.63	17.32	19.06	20.88
F Approx.	1.36E-02	1.34E-02	1.16E-02	1.44E-02	1.31E-02	1.20E-02
$1/F^{1/2}$	8.58	8.65	9.30	8.32	8.73	9.14
$1/F^{1/2} Calc$	8.56	8.63	9.30	8.30	8.71	9.13
$h_{c,dw}$	203.79	239.74	1294.87	48.09	129.30	359.02
h_{c-n}	0.00	0.00	0.00	0.00	0.00	0.00
h_{s-n}	0.00	0.00	0.00	0.00	0.00	0.00
h_{v-n}	2.48	2.97	18.54	0.72	2.12	6.46
$h_{c,hw}$	198.58	234.04	1274.93	46.31	126.31	353.50
TDH-HW	201.06	237.01	1293.47	47.03	128.44	359.96
TDH-DW	206.28	242.70	1313.41	48.81	131.42	365.48
HP _{brake-HW}	55.75	71.82	979.90	11.88	55.79	272.70
HP _{brake-DW}	57.20	73.55	995.01	12.33	57.08	276.88
Assumed total eff	0.65	0.65	0.65	0.65	0.65	0.65
HP _{hw}}	85.77	110.49	1507.54	18.27	85.82	419.54
HP _{dw}}	87.99	113.15	1530.78	18.96	87.82	425.97
Yds ³ /hr. (Production Rate)	32.62	35.65	89.13	29.71	51.10	89.13
10-Hr Days to Move .000 Yds ³ · 0.10 Solids*	76.64	70.13	28.05	84.15	48.92	28.05

Port of Brookings-Harbor
Calculation Sheet For 6" and 8", SDR 21 Pipeline, 120 hp
 by Jack Akln, MS, PE

Adjusted h_f -hw	327.66	1784.90	64.84	176.84	494.91
Adjusted HP _{hw} **	154.14	2101.91	25.47	119.59	584.34
Adjusted v_{50} (assumes 20% slurry)	1.84E-05	1.84E-05	1.84E-05	1.84E-05	1.84E-05
Adjusted R_c	3.42E+05	9.33E+05	2.39E+05	4.11E+05	7.17E+05
Adjusted $R_c^{0.9}$	9.55E+04	2.36E+05	6.93E+04	1.13E+05	1.86E+05
Adjusted F Log ₁₀ Precalc	-4.20E+00	-4.57E+00	-4.07E+00	-4.28E+00	-4.48E+00
Adjusted Square of Previous	17.66	20.87	16.57	18.29	20.09
Adjusted F Approx.	1.42E-02	1.20E-02	1.51E-02	1.37E-02	1.24E-02
Adjusted $1/F^{1/2}$	8.40	9.14	8.14	8.55	8.97
Adjusted $1/F^{1/2}$ Calc	8.38	9.13	8.12	8.53	8.95
Adjusted TDH _{DW}	217.58	1380.14	51.73	139.09	386.24
Adjusted HP _{DW}	92.82	1608.56	20.10	92.94	450.16

Notes

- * Production assumes 100% efficiency. The actual production rate and dredging period must be adjusted per project.
- ** Safe recommended coefficient of 1.4 for various concentrations of slurry when using Hazen Williams.



Example: Automating depth and movement

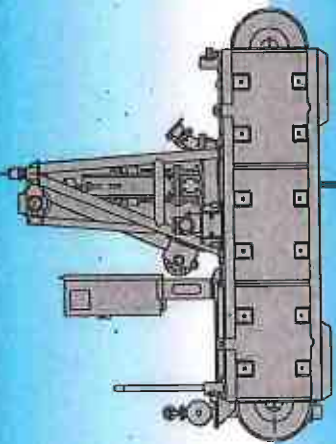

DIRECTION OF MOVEMENT →

WATER LEVEL

PUMP TRAJECTORY

TARGET DEPHT

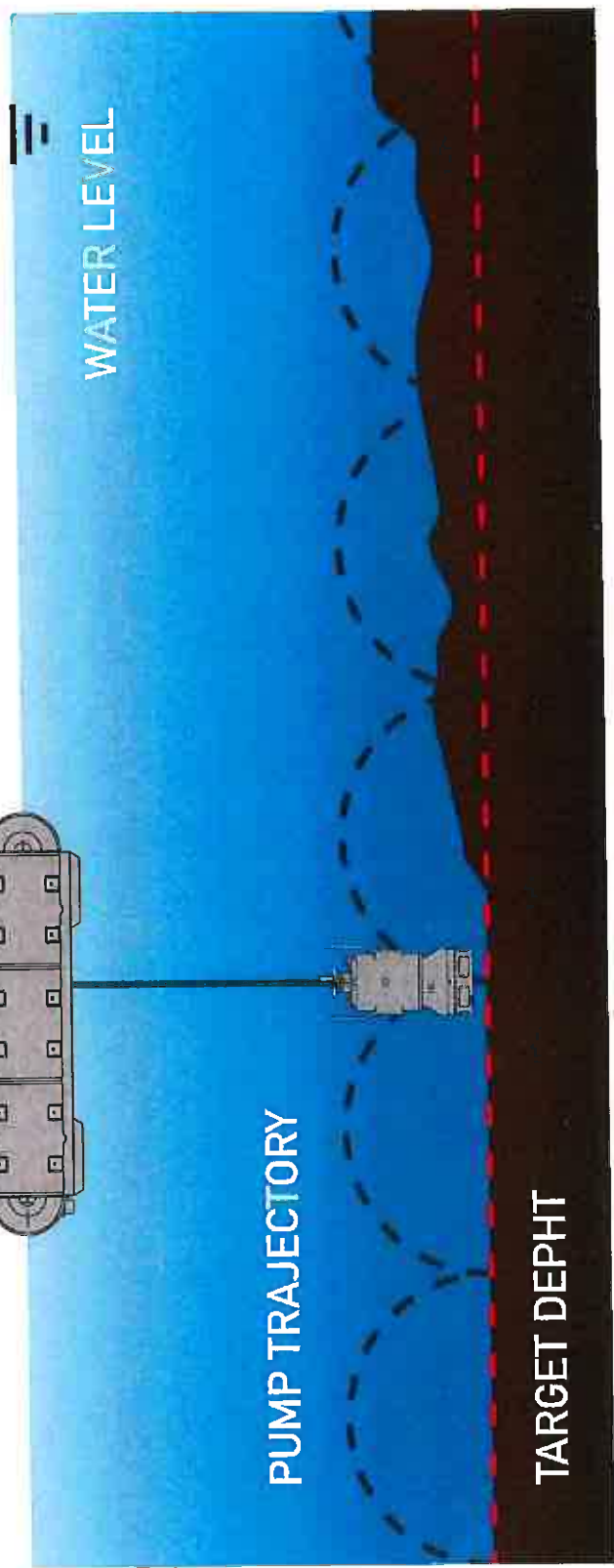

**EXHIBIT E – Bathymetric Comparison
to Investigate Shoaling Rates**



Grants Pass * Jacksonville * Medford, OR

GP Office: 1867 Williams Hwy., Suite 216, Grants Pass, OR, 97527

Jville Office: 450 Conestoga Dr., Jacksonville, OR, 97530

Ph: 541-474-9434 * Cell: 541-261-9929 * Fax 541-727-5488

emc@emcengineersscientists.com; <http://www.emcengineersscientists.com>

- Engineers/Scientists, LLC

7/10/19

Gary Dehlinger
Manager, Port of Brookings Harbor

7/10/19

Travis
Port of Brookings Harbor Harbormaster

MEMO 7102019-1; 2019 Bathymetric Survey Results

Attached are the key plans and volume calculations that indicate the volumes of sediments that have migrated into the Port of Brookings Harbor basins since shortly after the last major dredging event, which occurred in 2012, and that exists within the Port basins in 2019.

The bathymetric survey used to map out and compare 2013 volume levels with those in 2017 show a total volume increase of 16,683 yd.³. However, the most recently completed bathymetric survey has been mapped out, and its calculated volumes, utilizing the 2017 sediment elevations as its baseline, show a total sediment accumulation of 49,760 yd.³. If a standard averaging were to be used, the shoaling rate for the period between 2017 and 2019 can be estimated at approximately 24,880 yd.³ per year. This shoaling rate, when compared with the normally expected rate of about 4500 yd.³ per year, is dramatic, but not unexpected, based on observations that have been made in 2019.

As observed and previously estimated by EMC, it is believed that nearly all of 40,000 yd.³ has accumulated within the Port basins due to storms and erosion from nearby wild fire residues on stream watersheds to the Port. Nevertheless, even a conservative and weighted value of 24,880 yd.³ is about six times that which should be expected and have previously been observed to have shoaled into the Port basins.

Sincerely

Jack (John) Akin, MS, PE, IC, HMS, CAI
EMC-Engineers/Scientists, LLC

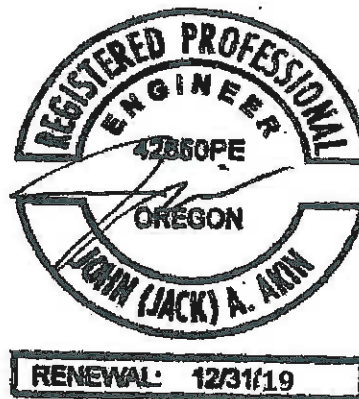

PORT OF BROOKINGS
POST-DREDGING VOLUMES

PRE-DREDGE SURVEY DATA SHOWN SUPPLIED BY
OREGON MARINE BOARD BASIN SURVEY
DATED: SEPTEMBER 16, 2017



POST-DREDGING
ADDITIONAL VOLUMES

AREA 1	9,517 CU. YDS.
AREA 2	784 CU. YDS.
AREA 3	6,382 CU. YDS.
TOTAL	16,683 CU. YDS.

NOTE: VOLUMES COMPARED
TO FEBRUARY, 2013 SURVEY



KEY PLAN



09-15-17

SHEET 1 OF 1

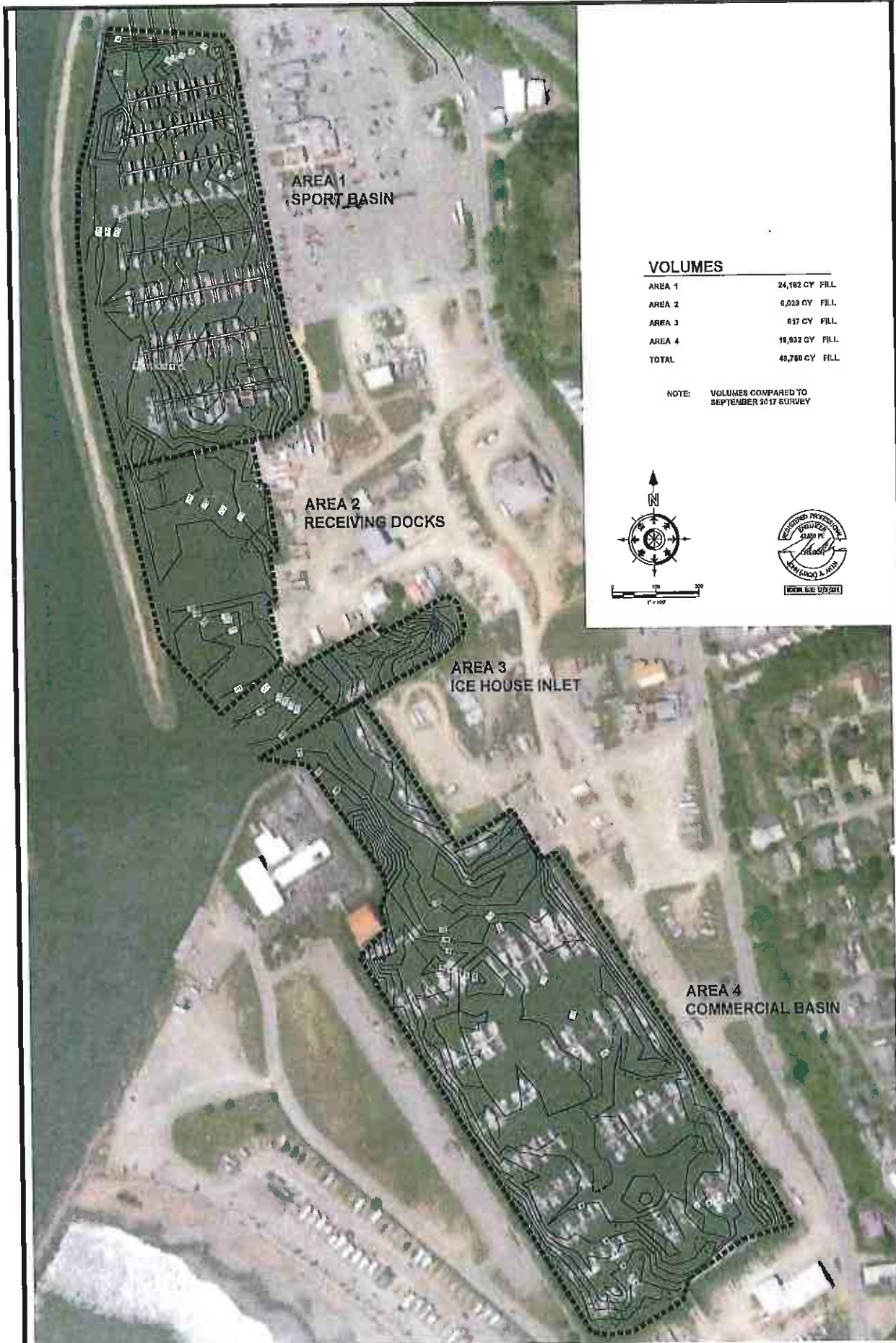

AREA 1
SPORT BASIN

AREA 2
RECEIVING DOCKS

AREA 3
ICE HOUSE INLET

AREA 4
COMMERCIAL BASIN

VOLUMES

AREA 1	24,182 CY FILL
AREA 2	6,029 CY FILL
AREA 3	617 CY FILL
AREA 4	19,932 CY FILL
TOTAL	49,760 CY FILL

NOTE: VOLUMES COMPARED TO SEPTEMBER 2017 SURVEY

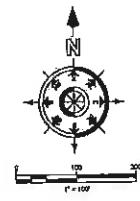

**EXHIBIT F – BCA Produced and
Submitted for HMGP Funding Request**



Benefit-Cost Calculator

V.6.0 (Build 20200819.1933)

Benefit-Cost Analysis

Project Name: POBH Embankment Stabilization/Stormwater Protection



Map Marker	Mitigation Title	Property Type	Hazard	Benefits (B)	Costs (C)	BCR (B/C)
1	Other @ 16330 Lower Harbor Rd, Brookings, Oregon, 97415_copy_copy_copy_copy	...	DFA - Severe Storm	\$ 7,446,159	\$ 4,302,140	1.73
2	Other @ 16330 Lower Harbor Rd, Brookings, Oregon, 97415_copy_copy_copy_copy	...	DFA - Severe Storm	\$ 7,446,159	\$ 4,302,140	1.73
TOTAL (SELECTED)				\$ 14,892,318	\$ 8,604,280	1.73
TOTAL				\$ 14,892,318	\$ 8,604,280	1.73

Property Configuration	
Property Title:	Other @ 16330 Lower Harbor Rd, Brookings, Oregon, 97415_copy_copy_copy_copy
Property Location:	97415, Curry, Oregon
Property Coordinates:	42.05127, -124.26676
Hazard Type:	Severe Storm
Mitigation Action Type:	Other
Property Type:	Other
Analysis Method Type:	Professional Expected Damages

Cost Estimation	
Other @ 16330 Lower Harbor Rd, Brookings, Oregon, 97415_copy_copy_copy_copy	
Project Useful Life (years):	40
Project Cost:	\$4,258,897
Number of Maintenance Years:	40 Use Default:Yes
Annual Maintenance Cost:	\$14,167

Comments•
Project Useful Life:

Not all work will last, without repair, for 40 years. Therefore note that for asphalt pavement construction, added ongoing expenses for periodic seal-coating and repair are added under Annual Maintenance Cost. Also, dredging having been done assumes subsequent normal sediment shoaling into the Port annually of 4500 cy. However, a 20% increase has been estimated from recent observations made by the engineer-of-record, which amounts to an additional 900 cy/yr, or 4500 cy/5 yrs. This amount over 40 years is placed under Damages After Mitigation in this BCA.

•
Mitigation Project Cost:

Please see the attached Project Budget Sheets (see attachments C-1, C-2 and C-3). These layout the three subprojects (Parking Lot, Roads & Storage; Boat Yard & Kite Field RV Park), with associated itemized cost estimates, totaling 1,858,897, which is the request from the HMGP (it may be that not enough funding via the HMGP is presently available, and so a PA request is also in process). This workbook contains three calculating sheets, the sheets are named "Parking Lot, Roads and Storage", "Boat Yard" and "Kite Field RV Park". In all three sheets the last column to the right, labeled "4452 HMGP", is that which is applicable to this project. So, for the sub-project "Parking Lot, Roads and Storage", the subtotal is \$546,805. The sub-project subtotal for the "Boat Yard" is \$812,828 The sub-project subtotal for the "Kite Field RV Park" is \$499,265. The total for all three of the sub-projects is \$1,858,897,. This total is added to the previously submitted total for the declared disasters during February (4432-DR-OR) and April (4452-DR-OR) of 2019. Attached FEMA inspections (see attachments E-1a, E-1b & E-1c for background and copies of WO 45060 and WO 47755) were conducted on 9/20/2019. Damage assessment via sequential bathymetric survey and historical photography were submitted to FEMA. As of the date of this Report, the approval process is in ongoing. Further, recent publication and engineering study has identified wildfire-related erosion and sedimentation within the Port basins. Upland layering would be used to beneficially grade surfaces for protective paving. Paving is recommended to 1) stabilize embankment slopes and control erosive stormwater flows, and 2) mitigate issues associated with the environmental threat outlined below. Additionally, stormwater pollutants are found to be posing a threat to the environment,. Recent (1st and 2nd 1/4ly, 2020) ODEQ-required stormwater sampling has shown the release of pollutants being delivered to the waters of the State. To these are added previously applied for 4432 and 4452 funding requests. 4432 requests \$755,000 and 4452 \$1,710,000 for embankment repair and sediment removal. Since that request we have found alternative sediment handling that can reduce, and that beneficially, 4452 costs by \$125,000, that is; from \$1,770,000 to \$1,645,000, and thus the total from \$2,525,000 to \$2,400,000. As a result of declared disasters during February (4432-DR-OR) and April (4452-DR-OR) of 2019 the Port of Brookings Harbor petitioned for assistance via the HMGP. Attached FEMA inspections (WO 45060 and WO 47755) were conducted on 9/20/2019. Damage assessment via sequential bathymetric survey and historical photography were submitted to FEMA. As of the date of this Report, the approval process is in ongoing. The total of all requests would therefore be \$4,258,897 which is the total Project Cost Estimation used for this BCA. Also, referenced within the Project Budget Sheets are preliminary engineered drawings (attached as B-4 and B-5). These are not construction drawings. RE the attached preliminary drawings: These drawings, entitled HMGP-DR-4452, 2020 Improvements, include some master planning, most but not all of which are applicable to this Project. All of these drawings, notes, specifications are adequate for cost estimation and regulatory review, but are preliminary. Construction drawings will follow. The drawing package consists of 21 sheets. Sheet C1.0 is the cover sheet for the packet.

280

Sheet C1.1 contains applicable General Notes, Grading Notes, etc. Sheet C1.2 contains other Notes and several Sections, all of which are applicable to this Project. Sheet C1.3 is simply an overall plan view of Basin 2. Sheets C2.0, 2.1 and 2.2 contain Notes and ESCP Details that are applicable to this project. Sheet C3.0 is of the Kite field – RV Park, showing 25 concrete pads and vehicle parking for pull-through RV units. This drawing will be revised to accommodate a total of 15, rather than 25 units. Cut and fill volumes as shown on the sheet are still correct. On a preliminary basis. Construction drawings will be more accurate, as they will be based on field surveyed data, rather than the GIS data presently being used. Sheet C4.0 is a preliminary drawing showing the north roads and parking lot, along with dredge sediments cut and fill volumes. The storage buildings on Sheet C4.0, as well as the details on Sheets C4A & C4B, the photos on Sheet C4C do not pertain to this project. The top and profile views of the roads on Sheets C4.1 through C4.6 are preliminary and applicable, but must be revised for construction drawings after professional survey or data is obtained. Sheet C5.0 shows the Boat Yard with planned cut and fill estimates, applicable to this project. Sheet C6.0 provides pre-design cross sections and Notes as specified by the engineer-of-record for wheel stops, curb with taper, conduit trenching, sewer trenching, concrete sidewalk, vertical curbing, curb and gutter, rolled curbing, control Joints, water and joint trenching, driveway guttering, typical clean outs, storm manholes, catch and junction basin details, all of which are applicable to this project. Under the newly obtained ODEQ 1200-Z Industrial Stormwater Permit, the Port completed its first two water sampling events and the laboratory results show considerable exceedances. The 5-14-20 Stormwater Review and Recommendations and POBH SWPCP for reference (see attached D-4a and D-4b) indicate that dirt/gravel roads, gear storage and boat yard facilities contribute to the non-compliant total suspended solids and regulated metals. Needed stormwater control as would be provided via paved surfaces directed to catch basins with Best Management practices.

Annual Maintenance Cost:

Proposed improvements (cut/fill, paving, embankment repair & stabilization) will decrease maintenance requirements. At present unpaved areas and unstable slopes must be routinely, temporarily repaired. Assuming a rigorous sealcoating schedule every three years, annual paved road and parking lot maintenance costs may be conservatively estimated at \$14,167/yr.

Damage Analysis Parameters - Damage Frequency Assessment
 Other @ 16330 Lower Harbor Rd, Brookings, Oregon, 97415_copy_copy_copy_copy

Year of Analysis Conducted:	2020
Year Property was Built:	1978
Analysis Duration:	43 Use Default:Yes

Professional Expected Damages Before Mitigation
 Other @ 16330 Lower Harbor Rd, Brookings, Oregon, 97415_copy_copy_copy_copy

Recurrence Interval (years)	OTHER	OPTIONAL DAMAGES			VOLUNTEER COSTS		TOTAL
	Damages (\$)	Category 1 (\$)	Category 2 (\$)	Category 3 (\$)	Number of Volunteers	Number of Days	Damages (\$)
8	2,525,000	0	0	0	0	0	3,550,000
1	95,758	0	0	0	0	0	95,758

Comments

Damages Before Mitigation:

Expected Damages are considered to be the cost of damage repair to restore action areas to their original condition (\$2,525,000). This budget has been submitted to FEMA via DR 4432 and 4452. An 8-yr. recurrence is deemed reasonable because, as noted in the attached Special Districts 2018 POBH NHMP (see attachment F-1, P13, Gen. SW Drainage, and P14, Embankments), degradation due to flood and storm damage is accelerating. Ongoing erosion and structural damage to Port, as seen from repairs required due to storm/flood damages in the last eight (8) years total, not including that caused by the 2011 tsunami, \$4,645,000 (\$120k+\$280k+\$650k+\$3595k), is shown in the Application, Section 3.1.5, Table. Attached engineering reports for these disasters over the last eight years are, respectively, GeoDesign Engineering Report and accompanying Overall Map of Slides; POBH Dock Failure Preliminary Reports-1 and 2; 3-24-17 Sport Basin Boardwalk Memo and, the most recent submitted 4432 and 4452 application; (WO 45060 & WO 47755 attached for the convenience of the reader). Projects not being done at present, that are already in-progress or have already been completed are not included in this BCA, except to support the overall periodicity of severe storm/erosive damages. RE required annual stormwater treatment as a result of newly discovered Port NPDES (1200-Z) non-compliance: Bioretention areas, swales, channels, detention areas, sand filters, gravity separators, dry wells, trenches, stormwater ponds, pavers, porous concrete, rain harvesting, and stormwater wetlands were reviewed. Swales, retention areas, trenches, ponds, harvesting and stormwater wetlands are not feasible due to limited treatment areas and high flows. R-D-I 50 for the Brookings area w/ Tc (3-6 minutes) estimated at 4.0. High intensity storms in the area require a coefficient adjustment of 1.2. The total volume of stormwater produced by the 18 acres area produces 73.34 ft.³/s, or about 32,917 GPM. Estimated stormwater treatment costs/yr., based on previous work reviewed by EMC, to treat to benchmark concentrations is about \$2.91/GPM/season. Attached is the 5-14-20 Stormwater Review and Recommendations, and the POBH SWPCP for reference. (Note: Reviewer can see all attached documents, spreadsheets, drawings citations in the "Attachment Index" Table in the Application.)

Annualized Damages Before Mitigation
Other @ 16330 Lower Harbor Rd, Brookings, Oregon, 97415_copy_copy_copy_copy

Annualized Recurrence Interval (years)	Damages and Losses (\$)	Annualized Damages and Losses (\$)
1	95,758	510,164
8	3,550,000	443,750
	Sum Damages and Losses (\$)	Sum Annualized Damages and Losses (\$)
	3,645,758	953,914

Professional Expected Damages After Mitigation
Other @ 16330 Lower Harbor Rd, Brookings, Oregon, 97415_copy_copy_copy_copy

Recurrence Interval (years)	OTHER	OPTIONAL DAMAGES			VOLUNTEER COSTS		TOTAL
	Damages (\$)	Category 1 (\$)	Category 2 (\$)	Category 3 (\$)	Number of Volunteers	Number of Days	Damages (\$)
5	1,282,500	0	0	0	0	0	1,282,500
1	23,500	0	0	0	0	0	23,500

Comments

Damages After Mitigation:

A recent bathymetric survey analyses was performed by the Port showing elevated shoaling rates, attributable to recent wildfires above the Chetco watershed. It is attached, entitled Memo RE Elevated 2017-2019 Shoaling Rates. The narrative examines recent shoaling rates as about six times that of average experienced at the Port. However, this phenomenon can not be predicted via available research. A 20% increase has been estimated from recent observations made by the engineer-of-record, which amounts to an additional 900 cy/yr, or 4500 cy/5 yrs. Therefore the average rate of 4500 cy sediment/yr. is used in this analysis. The dredging estimate of \$57/cy, disposed to EPA-managed ocean unit, is conservatively used. This volume is funded via Port resources. Paving and embankment repair are included in the maintenance cost/yr section of this analysis. Stormwater treatment to obtain acceptable levels will be greatly diminished by separating stormwater from Port soils, but not entirely diminished. Final polishing will likely be required at Gear Storage # 1 and Boat Yard. Filtering is estimated to cost about \$12,750 per outfall/year for the two outfalls.

Annualized Damages After Mitigation
Other @ 16330 Lower Harbor Rd, Brookings, Oregon, 97415_copy_copy_copy_copy

Annualized Recurrence Interval (years)	Damages and Losses (\$)	Annualized Damages and Losses (\$)
1	23,500	138,884
5	1,282,500	256,500
	Sum Damages and Losses (\$)	Sum Annualized Damages and Losses (\$)
	1,306,000	395,384

Benefits-Costs Summary
Other @ 16330 Lower Harbor Rd, Brookings, Oregon, 97415_copy_copy_copy_copy

Total Standard Mitigation Benefits:	\$7,446,159
Total Additional Benefits - Social:	\$0
Total Additional Benefits - Ecosystem Services:	\$0
Total Mitigation Project Benefits:	\$7,446,159
Total Mitigation Project Cost:	\$4,302,140
Benefit Cost Ratio - Standard:	1.73
Benefit Cost Ratio - Standard + Additional:	1.73

Property Configuration	
Property Title:	Other @ 16330 Lower Harbor Rd, Brookings, Oregon, 97415_copy_copy_copy_copy_copy
Property Location:	97415, Curry, Oregon
Property Coordinates:	42.05127, -124.26676
Hazard Type:	Severe Storm
Mitigation Action Type:	Other
Property Type:	Other
Analysis Method Type:	Professional Expected Damages

Cost Estimation	
Other @ 16330 Lower Harbor Rd, Brookings, Oregon, 97415_copy_copy_copy_copy_copy	
Project Useful Life (years):	40
Project Cost:	\$4,258,897
Number of Maintenance Years:	40 Use Default:Yes
Annual Maintenance Cost:	\$14,167

Comments•
Project Useful Life:

Not all work will last, without repair, for 40 years. Therefore note that for asphalt pavement construction, added ongoing expenses for periodic seal-coating and repair are added under Annual Maintenance Cost. Also, dredging having been done assumes subsequent normal sediment shoaling into the Port annually of 4500 cy. However, a 20% increase has been estimated from recent observations made by the engineer-of-record, which amounts to an additional 900 cy/yr., or 4500 cy/5 yrs. This amount over 40 years is placed under Damages After Mitigation in this BCA.

•
Mitigation Project Cost:

Please see the attached Project Budget Sheets (see attachments C-1, C-2 and C-3). These layout the three subprojects (Parking Lot, Roads & Storage; Boat Yard & Kite Field RV Park), with associated itemized cost estimates, totaling 1,858,897, which is the request from the HMGP (it may be that not enough funding via the HMGP is presently available, and so a PA request is also in process). This workbook contains three calculating sheets, the sheets are named "Parking Lot, Roads and Storage", "Boat Yard" and "Kite Field RV Park". In all three sheets the last column to the right, labeled "4452 HMGP", is that which is applicable to this project. So, for the sub-project "Parking Lot, Roads and Storage", the subtotal is \$546,805. The sub-project subtotal for the "Boat Yard" is \$812,828 The sub-project subtotal for the "Kite Field RV Park" is \$499,265. The total for all three of the sub-projects is \$1,858,897,. This total is added to the previously submitted total for the declared disasters during February (4432-DR-OR) and April (4452-DR-OR) of 2019. Attached FEMA inspections (see attachments E-1a, E-1b & E-1c for background and copies of WO 45060 and WO 47755) were conducted on 9/20/2019. Damage assessment via sequential bathymetric survey and historical photography were submitted to FEMA. As of the date of this Report, the approval process is in ongoing. Further, recent publication and engineering study has identified wildfire-related erosion and sedimentation within the Port basins. Upland layering would be used to beneficially grade surfaces for protective paving. Paving is recommended to 1) stabilize embankment slopes and control erosive stormwater flows, and 2) mitigate issues associated with the environmental threat outlined below. Additionally, stormwater pollutants are found to be posing a threat to the environment,. Recent (1st and 2nd 1/4ly, 2020) ODEQ-required stormwater sampling has shown the release of pollutants being delivered to the waters of the State. To these are added previously applied for 4432 and 4452 funding requests. 4432 requests \$755,000 and 4452 \$1,710,000 for embankment repair and sediment removal. Since that request we have found alternative sediment handling that can reduce, and that beneficially, 4452 costs by \$125,000, that is; from \$1,770,000 to \$1,645,000, and thus the total from \$2,525,000 to \$2,400,000. As a result of declared disasters during February (4432-DR-OR) and April (4452-DR-OR) of 2019 the Port of Brookings Harbor petitioned for assistance via the HMGP. Attached FEMA inspections (WO 45060 and WO 47755) were conducted on 9/20/2019. Damage assessment via sequential bathymetric survey and historical photography were submitted to FEMA. As of the date of this Report, the approval process is in ongoing. The total of all requests would therefore be \$4,258,897 which is the total Project Cost Estimation used for this BCA. Also, referenced within the Project Budget Sheets are preliminary engineered drawings (attached as B-4 and B-5). These are not construction drawings. RE the attached preliminary drawings: These drawings, entitled HMGP-DR-4452, 2020 Improvements, include some master planning, most but not all of which are applicable to this Project. All of these drawings, notes, specifications are adequate for cost estimation and regulatory review, but are preliminary. Construction drawings will follow. The drawing package consists of 21 sheets. Sheet C1.0 is the cover sheet for the packet.

285

Sheet C1.1 contains applicable General Notes, Grading Notes, etc. Sheet C1.2 contains other Notes and several Sections, all of which are applicable to this Project. Sheet C1.3 is simply an overall plan view of Basin 2. Sheets C2.0, 2.1 and 2.2 contain Notes and ESCP Details that are applicable to this project. Sheet C3.0 is of the Kite field – RV Park, showing 25 concrete pads and vehicle parking for pull-through RV units. This drawing will be revised to accommodate a total of 15, rather than 25 units. Cut and fill volumes as shown on the sheet are still correct. On a preliminary basis. Construction drawings will be more accurate, as they will be based on field surveyed data, rather than the GIS data presently being used. Sheet C4.0 is a preliminary drawing showing the north roads and parking lot, along with dredge sediments cut and fill volumes. The storage buildings on Sheet C4.0, as well as the details on Sheets C4A & C4B, the photos on Sheet C4C do not pertain to this project. The top and profile views of the roads on Sheets C4.1 through C4.6 are preliminary and applicable, but must be revised for construction drawings after professional survey or data is obtained. Sheet C5.0 shows the Boat Yard with planned cut and fill estimates, applicable to this project. Sheet C6.0 provides pre-design cross sections and Notes as specified by the engineer-of-record for wheel stops, curb with taper, conduit trenching, sewer trenching, concrete sidewalk, vertical curbing, curb and gutter, rolled curbing, control Joints, water and joint trenching, driveway guttering, typical clean outs, storm manholes, catch and junction basin details, all of which are applicable to this project. Under the newly obtained ODEQ 1200-Z Industrial Stormwater Permit, the Port completed its first two water sampling events and the laboratory results show considerable exceedances. The 5-14-20 Stormwater Review and Recommendations and POBH SWPCP for reference (see attached D-4a and D-4b) indicate that dirt/gravel roads, gear storage and boat yard facilities contribute to the non-compliant total suspended solids and regulated metals. Needed stormwater control as would be provided via paved surfaces directed to catch basins with Best Management practices.

Annual Maintenance Cost:

Proposed improvements (cut/fill, paving, embankment repair & stabilization) will decrease maintenance requirements. At present unpaved areas and unstable slopes must be routinely, temporarily repaired. Assuming a rigorous sealcoating schedule every three years, annual paved road and parking lot maintenance costs may be conservatively estimated at \$14,167/yr.

Damage Analysis Parameters - Damage Frequency Assessment
 Other @ 16330 Lower Harbor Rd, Brookings, Oregon, 97415_copy_copy_copy_copy_copy

Year of Analysis Conducted:	2020
Year Property was Built:	1978
Analysis Duration:	43 Use Default:Yes

Professional Expected Damages Before Mitigation
 Other @ 16330 Lower Harbor Rd, Brookings, Oregon, 97415_copy_copy_copy_copy_copy

Recurrence Interval (years)	OTHER	OPTIONAL DAMAGES			VOLUNTEER COSTS		TOTAL
	Damages (\$)	Category 1 (\$)	Category 2 (\$)	Category 3 (\$)	Number of Volunteers	Number of Days	Damages (\$)
8	2,525,000	0	0	0	0	0	3,550,000
1	95,758	0	0	0	0	0	95,758

Comments

Damages Before Mitigation:

Expected Damages are considered to be the cost of damage repair to restore action areas to their original condition (\$2,525,000). This budget has been submitted to FEMA via DR 4432 and 4452. An 8-yr. recurrence is deemed reasonable because, as noted in the attached Special Districts 2018 POBH NHMP (see attachment F-1, P13, Gen. SW Drainage, and P14, Embankments), degradation due to flood and storm damage is accelerating. Ongoing erosion and structural damage to Port, as seen from repairs required due to storm/flood damages in the last eight (8) years total, not including that caused by the 2011 tsunami, \$4,645,000 (\$120k+\$280k+\$650k+\$3595k), is shown in the Application, Section 3.1.5, Table. Attached engineering reports for these disasters over the last eight years are, respectively, GeoDesign Engineering Report and accompanying Overall Map of Slides; POBH Dock Failure Preliminary Reports-1 and 2; 3-24-17 Sport Basin Boardwalk Memo and, the most recent submitted 4432 and 4452 application; (WO 45060 & WO 47755 attached for the convenience of the reader). Projects not being done at present, that are already in-progress or have already been completed are not included in this BCA, except to support the overall periodicity of severe storm/erosive damages. RE required annual stormwater treatment as a result of newly discovered Port NPDES (1200-Z) non-compliance: Bioretention areas, swales, channels, detention areas, sand filters, gravity separators, dry wells, trenches, stormwater ponds, pavers, porous concrete, rain harvesting, and stormwater wetlands were reviewed. Swales, retention areas, trenches, ponds, harvesting and stormwater wetlands are not feasible due to limited treatment areas and high flows. R-D-1 50 for the Brookings area w/ Tc (3-6 minutes) estimated at 4.0. High intensity storms in the area require a coefficient adjustment of 1.2. The total volume of stormwater produced by the 18 acres area produces 73.34 ft.³/s, or about 32,917 GPM. Estimated stormwater treatment costs/yr, based on previous work reviewed by EMC, to treat to benchmark concentrations is about \$2.91/GPM/season. Attached is the 5-14-20 Stormwater Review and Recommendations, and the POBH SWPCP for reference. (Note: Reviewer can see all attached documents, spreadsheets, drawings citations in the "Attachment Index" Table in the Application.)

Annualized Damages Before Mitigation
Other @ 16330 Lower Harbor Rd, Brookings, Oregon, 97415_copy_copy_copy_copy_copy

Annualized Recurrence Interval (years)	Damages and Losses (\$)	Annualized Damages and Losses (\$)
1	95,758	510,164
8	3,550,000	443,750
	Sum Damages and Losses (\$)	Sum Annualized Damages and Losses (\$)
	3,645,758	953,914

Professional Expected Damages After Mitigation
Other @ 16330 Lower Harbor Rd, Brookings, Oregon, 97415_copy_copy_copy_copy_copy

Recurrence Interval (years)	OTHER	OPTIONAL DAMAGES			VOLUNTEER COSTS		TOTAL
	Damages (\$)	Category 1 (\$)	Category 2 (\$)	Category 3 (\$)	Number of Volunteers	Number of Days	Damages (\$)
5	1,282,500	0	0	0	0	0	1,282,500
1	23,500	0	0	0	0	0	23,500

Comments

•

Damages After Mitigation:

A recent bathymetric survey analyses was performed by the Port showing elevated shoaling rates, attributable to recent wildfires above the Chetco watershed. It is attached, entitled Memo RE Elevated 2017-2019 Shoaling Rates. The narrative examines recent shoaling rates as about six times that of average experienced at the Port. However, this phenomenon can not be predicted via available research. A 20% increase has been estimated from recent observations made by the engineer-of-record, which amounts to an additional 900 cy/yr., or 4500 cy/5 yrs. Therefore the average rate of 4500 cy sediment/yr. is used in this analysis. The dredging estimate of \$57/cy, disposed to EPA-managed ocean unit, is conservatively used. This volume is funded via Port resources. Paving and embankment repair are included in the maintenance cost/yr section of this analysis. Stormwater treatment to obtain acceptable levels will be greatly diminished by separating stormwater from Port soils, but not entirely diminished. Final polishing will likely be required at Gear Storage # 1 and Boat Yard. Filtering is estimated to cost about \$12,750 per outfall/year for the two outfalls.

Annualized Damages After Mitigation

Other @ 16330 Lower Harbor Rd, Brookings, Oregon, 97415_copy_copy_copy_copy_copy

Annualized Recurrence Interval (years)	Damages and Losses (\$)	Annualized Damages and Losses (\$)
1	23,500	138,884
5	1,282,500	256,500
	Sum Damages and Losses (\$)	Sum Annualized Damages and Losses (\$)
	1,306,000	395,384

Benefits-Costs Summary

Other @ 16330 Lower Harbor Rd, Brookings, Oregon, 97415_copy_copy_copy_copy_copy

Total Standard Mitigation Benefits:	\$7,446,159
Total Additional Benefits - Social:	\$0
Total Additional Benefits - Ecosystem Services:	\$0
Total Mitigation Project Benefits:	\$7,446,159
Total Mitigation Project Cost:	\$4,302,140
Benefit Cost Ratio - Standard:	1.73
Benefit Cost Ratio - Standard + Additional:	1.73



**PORT OF BROOKINGS-HARBOR
2021 CIVIL IMPROVEMENTS
SEDIMENT STOCKPILE
LOCATION #2**

NATURAL FEATURES
EXISTING NATURAL RESOURCES OR NATURAL HAZARDS ON THE SUBJECT PROPERTY, INCLUDING WETLANDS, STREAMS, RIPARIAN AREAS, FLOOD PLAINS, OR FLOODWAYS TO BE DETERMINED BY ENGINEER.

EXISTING TREE CANOPY
THERE ARE NO EXISTING TREES ON THE SUBJECT PROPERTY.

CULTURAL RESOURCES
LOCAL, OR FEDERALLY DESIGNATED HISTORIC AND/OR CULTURAL RESOURCES ON THE SITE OR ON ADJACENT PARCELS TO BE DETERMINED BY ENGINEER.

PUBLIC UTILITIES
PUBLIC UTILITY SERVICES, INCLUDING WATER, SEWER, STORM DRAINAGE, POWER, TELEPHONE, CABLE INTERNET, AND GAS ARE AVAILABLE TO THE SUBJECT PROPERTY.

UTILITY STATEMENT
EXISTING UNDERGROUND UTILITIES ILLUSTRATED IN THESE PLANS ARE APPROXIMATED BASED ON MAPS OBTAINED FROM CURRY COUNTY GIS ELEVATIONS ESTIMATES, OR HAVE BEEN LOCATED BY A UTILITY LOCATE COMPANY. LAYOUT INDICATED IS NOT TO BE RELIED ON AS BEING EXACT OR COMPLETE. ALL LINES WITHIN PROJECTED WORK ZONE SHALL BE FIELD VERIFIED AS REQUIRED PRIOR TO CONSTRUCTION.

PROJECT DESCRIPTION

TITLE: SEDIMENT STOCKPILE
REFERENCE: PB114
LOCATION: HARBOR ST
TAX LOT(S): 2500

DRAWING REGISTER

PB114-C100 COVER SHEET
PB114-C101 GRADING NOTES
PB114-C102 EXISTING CONDITIONS
PB114-C103 PROPOSED SEDIMENT STOCKPILE



**PROJECT OVERVIEW
SCALE 1"=100'**

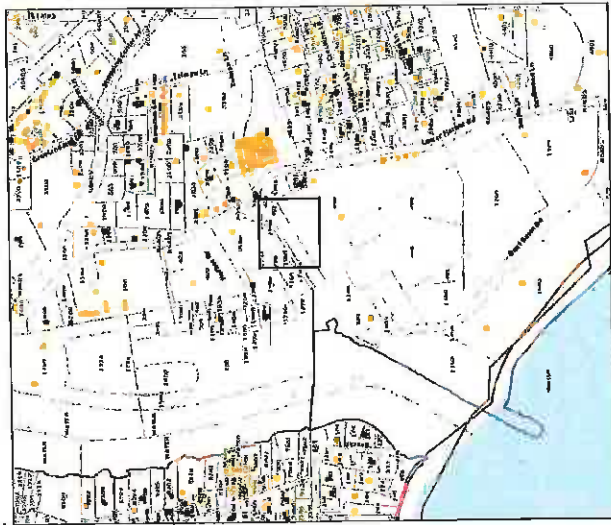

**PORT OF BROOKINGS HARBOR
MAP OF TAX LOTS**

PRELIM GRADING NOTES

1. DQ 1200-C PERMIT IS REQUIRED.
2. UNLESS DIRECTED OTHERWISE, REMOVE CLEARED AND GRUBBED MATERIAL FROM THE SITE AND DISPOSE AT AN APPROVED LOCATION.
3. VERIFY GRADES AT SAWCUT LOCATIONS AND MATCHING OF EXISTING GRADE LOCATIONS.
4. MINIMIZE TRAFFIC ON SOIL AREAS DURING WET WEATHER. IF THE SITE SOILS ARE EXPOSED DURING WET WEATHER, THE USE OF CRUSHED ROCK PLACED AS ENGINEERED FILL IN THE BOTTOM OF THE EXCAVATIONS MAY BE NECESSARY TO PROTECT THE SUBGRADE. TAKE ALL PRECAUTIONS TO LIMIT SURFACE DISTURBANCE AND PROTECT THE SITE GRADING AREA FROM EROSION AND RUNOFF.
5. UNLESS OTHERWISE NOTED, THE SAMPLING AND TESTING OF MATERIALS FOR USE ON THE JOBSITE SHALL BE AT THE EXPENSE OF THE CONTRACTOR. ALL TESTING OF MATERIALS AND WORKMANSHIP SHALL BE PERFORMED BY A CERTIFIED TESTER. RESULTS OF THE TESTS SHALL BE SENT DIRECTLY TO THE PROJECT ENGINEER AS WELL AS THE CONTRACTOR, BY THE LABORATORY. LOCATION AND FREQUENCY OF TESTS SHALL BE DESIGNATED BY THE GENERAL CONTRACTOR.
6. ALL CUT AND FILL SLOPES SHALL BE MAXIMUM OF 2:1.

LEGEND	
5	ELEVATION
---	SUBGRADE MINOR CONTOUR
---	SUBGRADE MAJOR CONTOUR
---	PARCEL
---	GEOTEXTILE
---	CONCRETE PAD
---	GRASS
---	JETTY
---	SLEP WAY
---	PAVED ROAD



EMC ENGINEERS
1400 NE Oregon Street, Suite 200, Brookings, OR 97515
Phone: 541-338-2228
Fax: 541-338-2229
www.emcengineers.com

PORT OF BROOKINGS
1630 Lower Harbor Rd, Brookings, OR 97515
PREPARED FOR: (LOT 2500, MAP 38022DB)
DATE: 04/04/2021
DRAWN BY: INFRADRAFT
SHEET NO.: C-100
FILE NO.: PB114

GRADING NOTES

1. PRIOR TO THE CONSTRUCTION OF EMBANKMENTS, THE CONTRACTOR SHALL EXCAVATE UNSUITABLE FOUNDATION MATERIAL, BASEMENTS, TRENCHES AND HOLES ENCOUNTERED WITHIN EMBANKMENT LIMITS SHALL BE FILLED WITH APPROVED MATERIAL. PRIOR TO BACKFILLING THE CONTRACTOR SHALL BREAK CONCRETE FLOORS OF BASEMENTS AS DIRECTED. THE CONTRACTOR SHALL BREAK UP AND ROUGHEN THE GROUND SURFACE BEFORE EMBANKMENTS MATERIAL IS PLACED THE NATURAL GROUND UNDERLYING EMBANKMENTS SHALL BE COMPACTED TO THE DENSITY SPECIFIED FOR THE EMBANKMENT MATERIALS TO BE PLACED, AND TO THE DEPTH OF THE GRUBBING OR A MINIMUM OF 6 INCHES.
2. EMBANKMENT CONSTRUCTION SHALL INCLUDE PREPARATION OF THE AREAS UPON WHICH EMBANKMENTS ARE PLACED, THE PLACEMENT AND COMPACTION OF APPROVED EMBANKMENT MATERIALS AND FILLING OF HOLES, PITS AND OTHER DEPRESSIONS WITHIN THE SUBDIVISION. THE CONTRACTOR SHALL PLACE EMBANKMENTS AND FILLS IN THE HORIZONTAL LAYERS OF 8 INCHES MAXIMUM DEPTH AND COMPACT EACH LAYER TO THE DENSITY SPECIFIED.
3. EMBANKMENT SHALL NOT BE CONSTRUCTED WHEN THE EMBANKMENT MATERIAL OR THE FOUNDATION ON WHICH THE EMBANKMENT WOULD BE PLACED IS FROZEN.
4. IMMEDIATELY PRIOR TO COMPLETION OF THE EARTHWORK, THE CONTRACTOR SHALL CLEAN THE ENTIRE WORK AREA OF DEBRIS AND FOREIGN MATTER.
5. THE MAXIMUM DENSITY OF COMPACTED MATERIAL WILL BE DETERMINED BY ASHTO T-99
6. THE CONTRACTOR SHALL COMPACT ALL EMBANKMENTS, FILLS AND BACKFILLS TO A MINIMUM IN PLACE DENSITY OF 95 PERCENT.
7. THE CONTRACTOR SHALL WATER THE MATERIALS TO PROVIDE OPTIMUM MOISTURE FOR COMPACTION OF EMBANKMENT AND BACKFILLS. EMBANKMENTS OF BACKFILL MATERIALS SHALL NOT BE PLACED IN FINAL POSITION UNTIL MOISTURE IN EXCESS OF OPTIMUM MOISTURE HAS BEEN REMOVED.
8. IF THE SPECIFIED COMPACTION IS NOT OBTAINED, THE CONTRACTOR SHALL NOTIFY THE ENGINEER. THE CONTRACTOR MAY BE REQUIRED TO USE A MODIFIED COMPACTION PROCEDURE OR APPLY ADDITIONAL COMPACTION EFFORT. IF APPROVED MATERIALS MEETING THE SPECIFICATIONS CANNOT BE COMPACTED TO THE REQUIRED DENSITY REGARDLESS OF COMPACTION EFFORT OR METHOD, THE ENGINEER MAY REDUCE THE REQUIRED DENSITY OR DIRECT THE ALTERNATE MATERIALS BE USED. IN NO CASE SHALL EARTHWORK OPERATIONS PROCEED UNTIL THE SATISFACTION OF THE ENGINEER.
9. DEQ 1200-C PERMIT IS NOT REQUIRED.
10. UNLESS DIRECTED OTHERWISE, REMOVE CLEARED AND GRUBBED MATERIAL FROM THE SITE AND DISPOSE AT AN APPROVED LOCATION.
11. UNLESS OTHERWISE NOTED, THE SAMPLING AND TESTING OF MATERIALS FOR USE ON THE JOBSITE SHALL BE AT THE EXPENSE OF THE CONTRACTOR. ALL TESTING OF MATERIALS AND WORKMANSHIP SHALL BE PERFORMED BY A CERTIFIED TESTER. RESULTS OF THE TESTS SHALL BE SENT DIRECTLY TO THE PROJECT ENGINEER AS WELL AS THE CONTRACTOR, BY THE LABORATORY. LOCATION AND FREQUENCY OF TESTS SHALL BE DESIGNATED BY THE GENERAL CONTRACTOR.
12. ALL CUT AND FILL SLOPES SHALL BE MAXIMUM OF 2:1.

GEOTECHNICAL NOTE

THE CONTRACTOR SHALL COORDINATE CONSTRUCTION ACTIVITIES WITH THE PROJECT ENGINEER FOR REQUIRED REMEDIATION. THE CONTRACTOR SHALL COORDINATE WITH THE PROJECT ENGINEER FOR REQUIRED SITE OBSERVATIONS AND TESTING OF ALL FILLS.

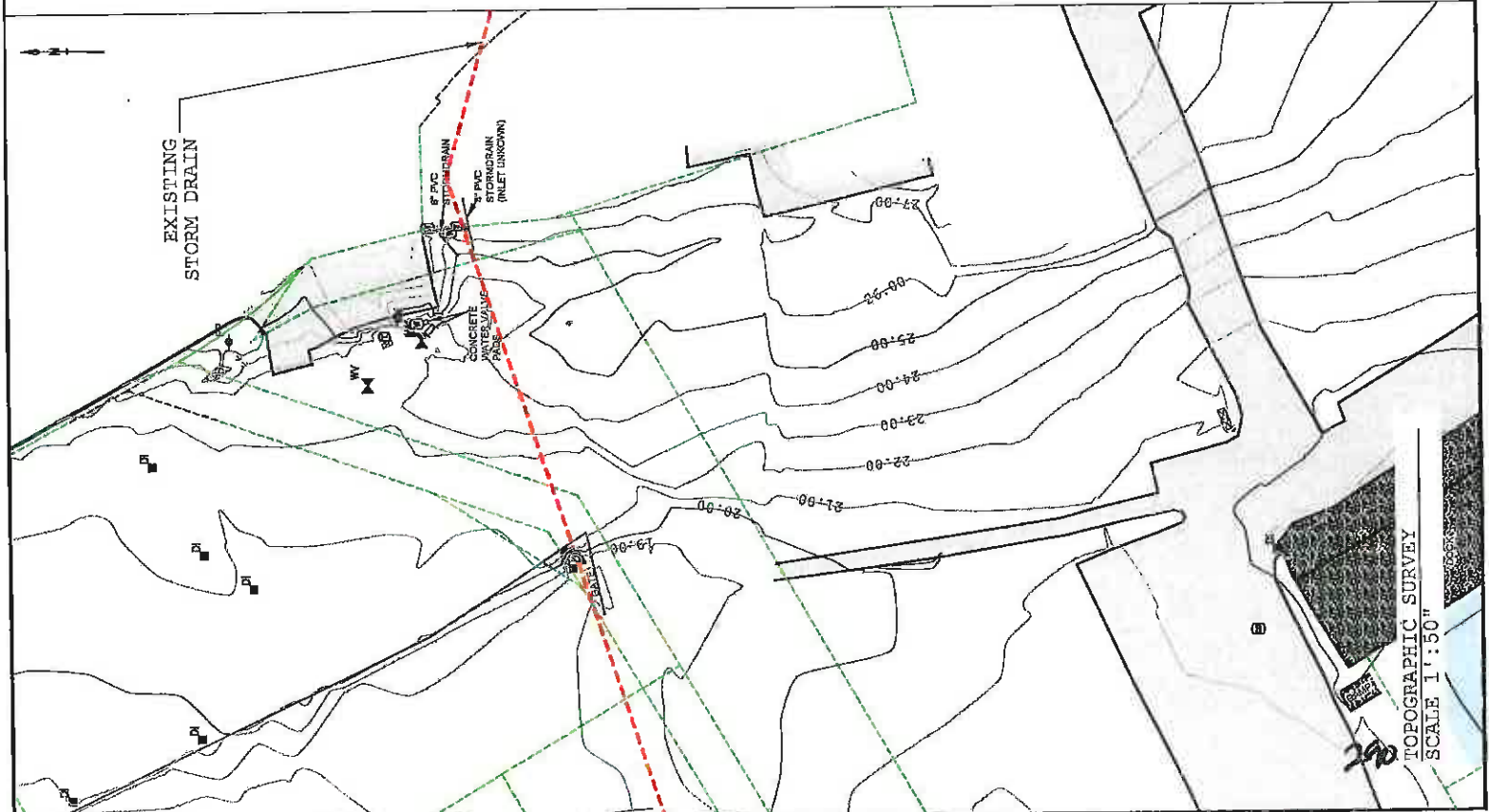

TOPOGRAPHIC SURVEY
SCALE 1"=50'

NEW SEDIMENT STORAGE AREA

AREA: 45,185SF
 APPROX. STORAGE CAPACITY
 7,350 cu.yards

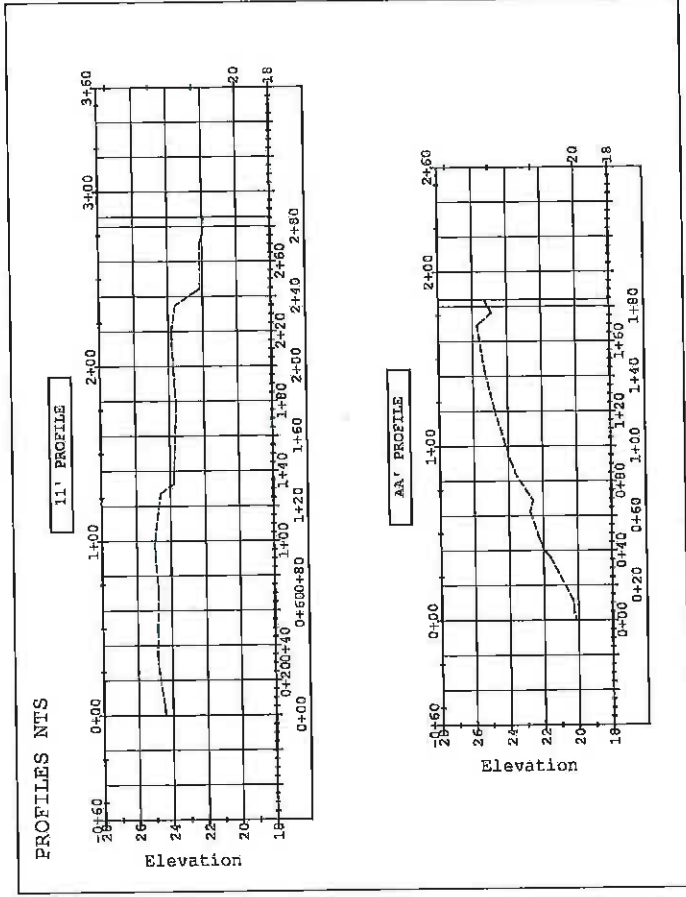

RETAINING WALL
 DETAIL NTS

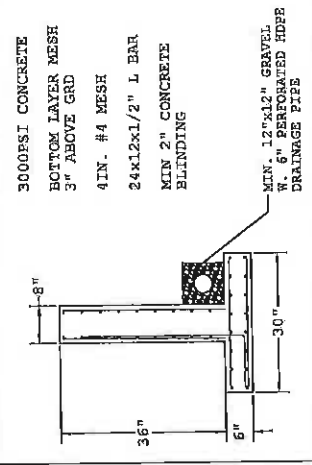
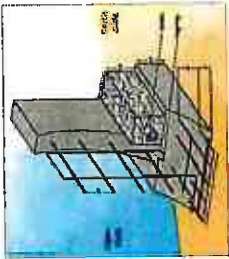

REINFORCED CONCRETE
 RETAINING WALL DETAIL

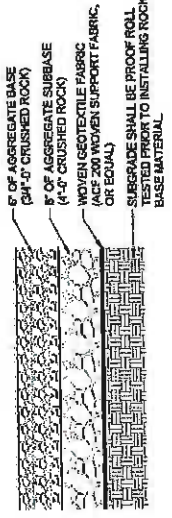

SUB-GRADE
 PREPARATION DETAIL

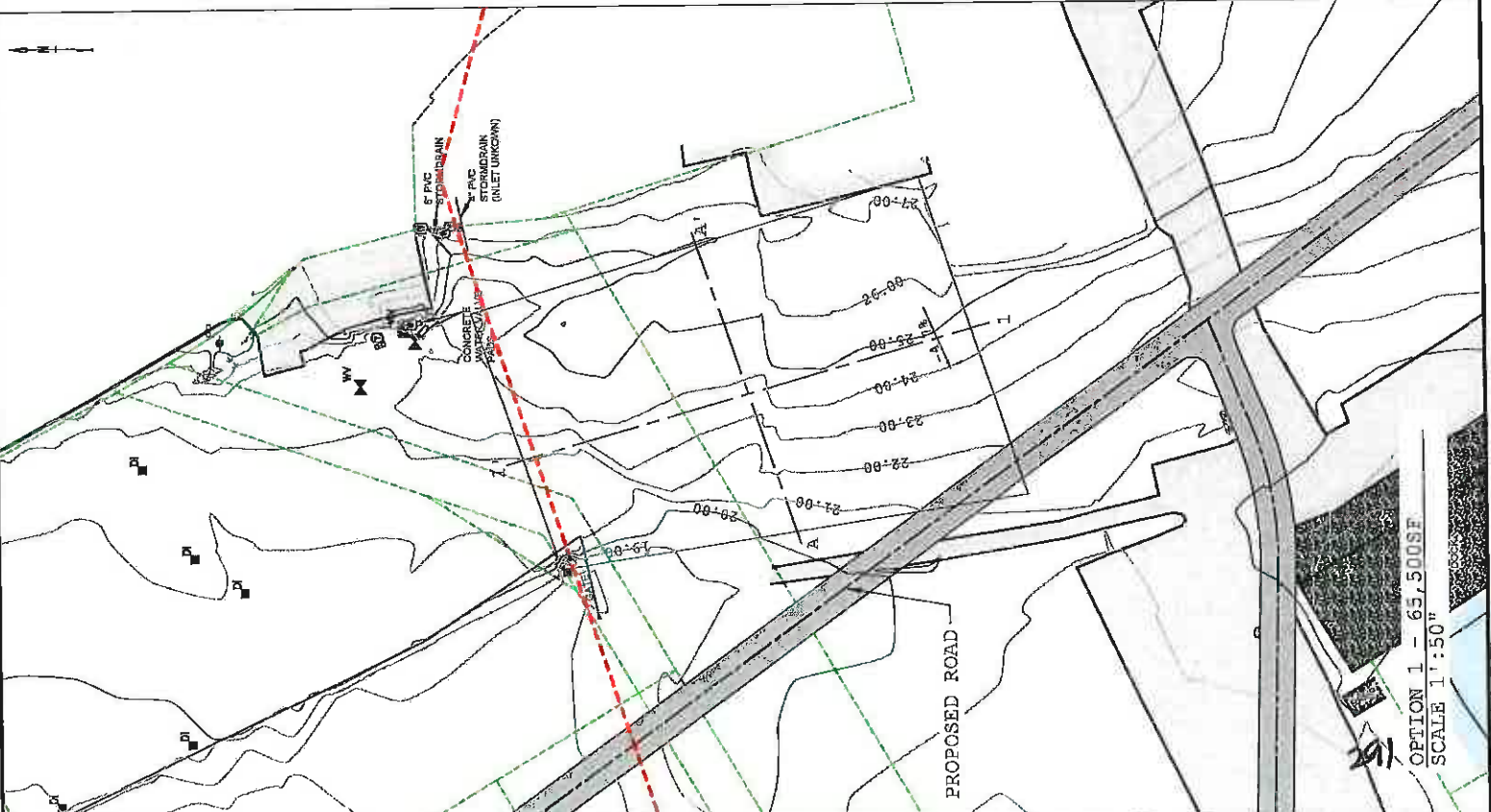

OPTION 1 - 65,500SF
 SCALE 1"=50'

NO.	DATE	REVISION



NEW SEDIMENT STORAGE AREA

LEGEND

	6" AGGREGATE BASE
	3/4"-0" CRUSHED ROCK
	8" AGGREGATE-SUBBASE
	4"-0" CRUSHED ROCK
	WOVEN GEOTEXTILE
	FABRIC ACF200
	PROOF ROLLED SUBGRADE
	ENGINEERED FILL

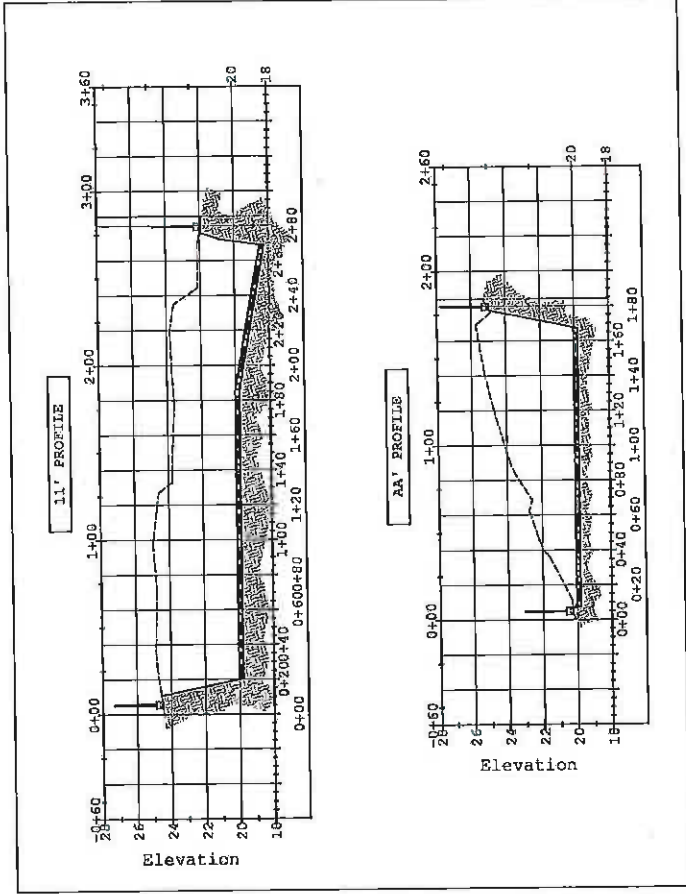

SEDIMENT STORAGE GRADING
NTS

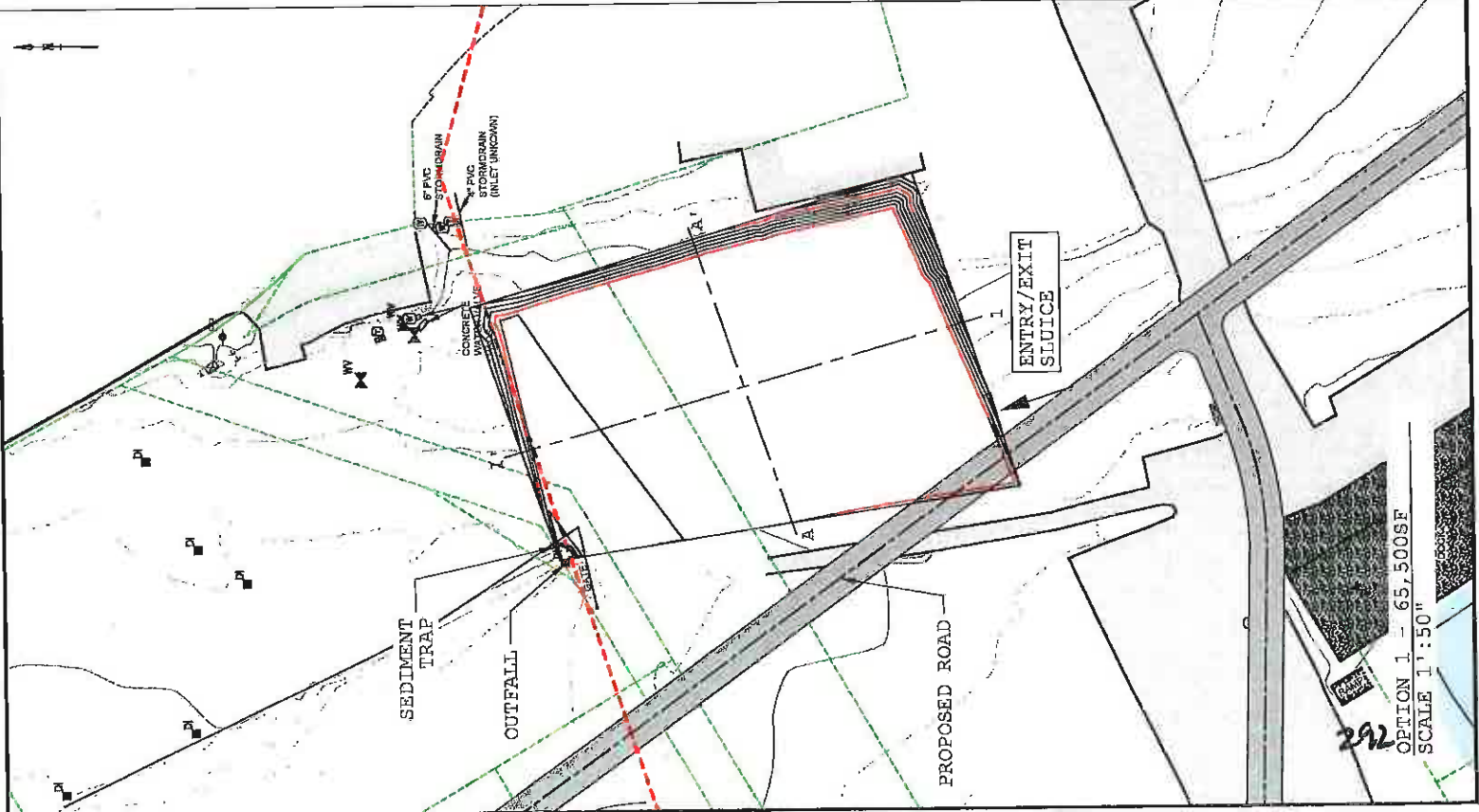

292
OPTION 1 - 65,500SF
SCALE 1"=50'

NO.	DATE	REVISION





PORT OF BROOKINGS-HARBOR
2021 CIVIL IMPROVEMENTS
PROPOSED ROAD

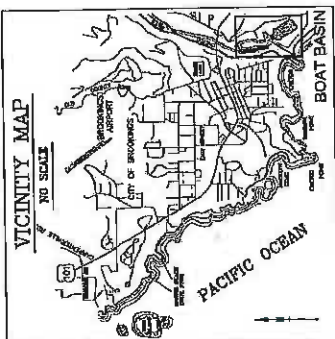

NATURAL FEATURES
EXISTING NATURAL RESOURCES OR NATURAL HAZARDS ON THE SUBJECT PROPERTY, INCLUDING WETLANDS, STREAMS, RIPARIAN AREAS, FLOOD PLAINS, OR FLOODWAYS TO BE DETERMINED BY ENGINEER

EXISTING TREE CANOPY
THERE ARE NO EXISTING TREES ON THE SUBJECT PROPERTY

CULTURAL RESOURCES
LOCALLY, OR FEDERALLY DESIGNATED HISTORIC AND/OR CULTURAL RESOURCES ON THE SITE OR ON ADJACENT PARCELS TO BE DETERMINED BY ENGINEER.

PUBLIC SERVICES
PUBLIC UTILITY SERVICES, INCLUDING WATER, SEWER, STORM DRAINAGE, POWER, TELEPHONE, CABLE INTERNET, AND GAS ARE AVAILABLE TO THE SUBJECT PROPERTY.

UTILITY STATEMENT
EXISTING UNDERGROUND UTILITIES ILLUSTRATED IN THESE PLANS ARE APPROXIMATED BASED ON MAPS OBTAINED FROM CURRY COUNTY GIS ELEVATIONS ESTIMATES, OR HAVE BEEN LOCATED BY A UTILITY LOCATE COMPANY. LAYOUT INDICATED IS NOT TO BE RELIED ON AS BEING EXACT OR COMPLETE. ALL LINES WITHIN PROTECTED WORK ZONE SHALL BE FIELD VERIFIED AS REQUIRED PRIOR TO CONSTRUCTION.

PROJECT DESCRIPTION
TITLE: PROPOSED ROAD
REFERENCE: 140
LOCATION: HARBOR ST
TAX LOT(S): 2500, 2600, 2700, 2800
2900, 2999, 402

DRAWING REGISTER
140-CV COVER SHEET
140-C100 NOTES
140-C101 EXISTING CONDITIONS
140-C102 PROPOSED GRADING
140-C103 PROPOSED PAVING
140-C104 PROPOSED DRAINAGE
140-C105 DETAILS
140-C106 DETAILS

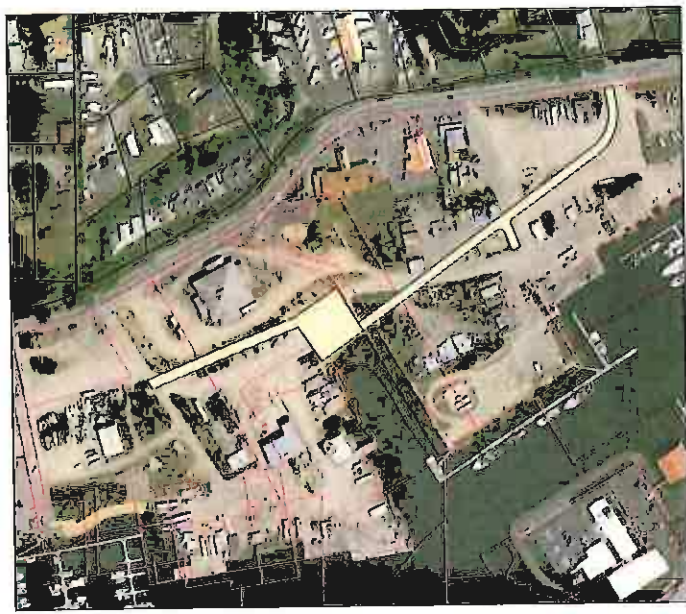

PROJECT OVERVIEW
SCALE 1"=200'

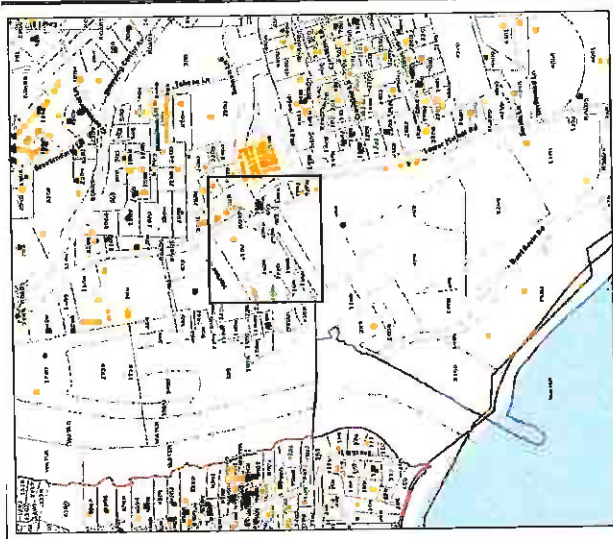

PORT OF BROOKINGS HARBOR
MAP OF TAX LOTS

- PRELIM GRADING NOTES**
1. DEQ 1200-C PERMIT IS REQUIRED.
 2. UNLESS DIRECTED OTHERWISE, REMOVE CLEARED AND GRUBBED MATERIAL FROM THE SITE AND DISPOSE AT AN APPROVED LOCATION, PRIOR TO THE START OF CONSTRUCTIONS.
 3. VERIFY GRADES AT SAWCUT LOCATIONS AND MATCHING OF EXISTING GRADE LOCATIONS.
 4. MINIMIZE TRAFFIC ON SOIL AREAS DURING WET WEATHER. IF THE SITE SOILS ARE EXPOSED DURING WET WEATHER, THE USE OF CRUSHED ROCK PLACED AS ENGINEERED FILL IN THE BOTTOM OF THE EXCAVATIONS MAY BE NECESSARY TO PROTECT THE SUBGRADE. TAKE ALL PRECAUTIONS TO LIMIT SURFACE DISTURBANCE AND PROTECT THE SITE GRADING AREA FROM EROSION AND RUNOFF.
 5. UNLESS OTHERWISE NOTED, THE SAMPLING AND TESTING OF MATERIALS FOR USE ON THE JOBSITE SHALL BE AT THE EXPENSE OF THE CONTRACTOR. ALL TESTING OF MATERIALS AND WORKMANSHIP SHALL BE PERFORMED BY A CERTIFIED TESTER. RESULTS OF THE TESTS SHALL BE SENT DIRECTLY TO THE PROJECT ENGINEER AS WELL AS THE CONTRACTOR, BY THE LABORATORY. LOCATION AND FREQUENCY OF TESTS SHALL BE DESIGNATED BY THE GENERAL CONTRACTOR.
 6. OF 2:1.

LEGEND

—	ELEVATION
—	SUBGRADE MINOR CONTOUR
—	SUBGRADE MAJOR CONTOUR
—	PARCEL
—	GEOTEXTILE
—	CONCRETE PAD
—	GRASS
—	JETTY WAY
—	PAVED ROAD



EMC
ENGINEERS
1530 Lower Harbor Rd, Brookings, OR 97415
PREPARED FOR: (LOT 2900, MAP 35022D9)
PORT OF BROOKINGS HARBOR
Date: 04/04/2021
Drawn By: INFRADRAFT
Sheet No.: CV
File No.: 140

GRADING NOTES

1. PRIOR TO THE CONSTRUCTION OF EMBANKMENTS, THE CONTRACTOR SHALL EXCAVATE UNSUITABLE FOUNDATION MATERIAL. BASEMENTS, TRENCHES AND HOLES ENCOUNTERED WITHIN EMBANKMENT LIMITS SHALL BE FILLED WITH APPROVED MATERIAL. PRIOR TO BACKFILLING THE CONTRACTOR SHALL BREAK CONCRETE FLOORS OF BASEMENTS AS DIRECTED. THE CONTRACTOR SHALL BREAK UP AND ROUGHEN THE GROUND SURFACE BEFORE EMBANKMENTS MATERIAL IS PLACED. THE NATURAL GROUND UNDERLYING EMBANKMENTS SHALL BE COMPACTED TO THE DENSITY SPECIFIED FOR THE EMBANKMENT MATERIALS TO BE PLACED, AND TO THE DEPTH OF THE GRUBBING OR A MINIMUM OF 6 INCHES.
2. EMBANKMENT CONSTRUCTION SHALL INCLUDE PREPARATION OF THE AREAS UPON WHICH EMBANKMENTS ARE PLACED, THE PLACEMENT AND COMPACTION OF APPROVED EMBANKMENT MATERIALS AND FILLING OF HOLES, PITS AND OTHER DEPRESSIONS WITHIN THE SUBDIVISION.
3. THE CONTRACTOR SHALL PLACE EMBANKMENTS AND FILLS IN THE HORIZONTAL LAYERS OF 8 INCHES MAXIMUM DEPTH AND COMPACT EACH LAYER TO THE DENSITY SPECIFIED.
4. EMBANKMENT SHALL NOT BE CONSTRUCTED WHEN THE EMBANKMENT MATERIAL OR THE FOUNDATION ON WHICH THE EMBANKMENT WOULD BE PLACED IS FROZEN.
5. IMMEDIATELY PRIOR TO COMPLETION OF THE EARTHWORK, THE CONTRACTOR SHALL CLEAN THE ENTIRE WORK AREA OF DEBRIS AND FOREIGN MATTER.
6. THE MAXIMUM DENSITY OF COMPACTED MATERIAL WILL BE DETERMINED BY AASHTO T-99
7. THE CONTRACTOR SHALL COMPACT ALL EMBANKMENTS, FILLS AND BACKFILLS TO A MINIMUM IN PLACE DENSITY OF 95 PERCENT.
8. THE CONTRACTOR SHALL WATER THE MATERIALS TO PROVIDE OPTIMUM MOISTURE FOR COMPACTION OF EMBANKMENT AND BACKFILLS. EMBANKMENTS OF BACKFILL MATERIALS SHALL NOT BE PLACED IN FINAL POSITION UNTIL MOISTURE IN EXCESS OF OPTIMUM MOISTURE HAS BEEN REMOVED.
9. IF THE SPECIFIED COMPACTION IS NOT OBTAINED, THE CONTRACTOR SHALL NOTIFY THE ENGINEER. THE CONTRACTOR MAY BE REQUIRED TO USE A MODIFIED COMPACTION PROCEDURE OR APPLY ADDITIONAL COMPACTIVE EFFORT. IF APPROVED MATERIALS MEETING THE SPECIFICATIONS CANNOT BE COMPACTED TO THE REQUIRED DENSITY REGARDLESS OF COMPACTIVE EFFORT OR METHOD, THE ENGINEER MAY REDUCE THE REQUIRED DENSITY OR DIRECT THE ALTERNATE MATERIALS BE USED. IN NO CASE SHALL EARTHWORK OPERATIONS PROCEED UNTIL THE CONTRACTOR IS ABLE TO COMPACT THE MATERIAL TO THE SATISFACTION OF THE ENGINEER.
10. DEQ 1200-C PERMIT IS NOT REQUIRED.
11. UNLESS DIRECTED OTHERWISE, REMOVE CLEARED AND GRUBBED MATERIAL FROM THE SITE AND DISPOSE AT AN APPROVED LOCATION.
12. UNLESS OTHERWISE NOTED, THE SAMPLING AND TESTING OF MATERIALS FOR USE ON THE JOBSITE SHALL BE AT THE EXPENSE OF THE CONTRACTOR. ALL TESTING OF MATERIALS AND WORKMANSHIP SHALL BE PERFORMED BY A CERTIFIED TESTER. RESULTS OF THE TESTS SHALL BE SENT DIRECTLY TO THE PROJECT ENGINEER AS WELL AS THE CONTRACTOR, BY THE LABORATORY. LOCATION AND FREQUENCY OF TESTS SHALL BE DESIGNATED BY THE GENERAL CONTRACTOR.
13. ALL CUT AND FILL SLOPES SHALL BE MAXIMUM OF 2:1.

GEOTECHNICAL NOTE

THE CONTRACTOR SHALL COORDINATE CONSTRUCTION ACTIVITIES WITH THE PROJECT ENGINEER FOR REQUIRED REMEDIATION. THE CONTRACTOR SHALL COORDINATE WITH THE PROJECT ENGINEER FOR REQUIRED SITE OBSERVATIONS AND TESTING OF ALL FILLS.

GENERAL NOTES

NO SCALE

294



NO.	DATE	REVISION



REV	REVISION	DATE



PREPARED FOR:
PORT OF BROOKINGS
 (LOT 2500, MAP '58052208')
 16330 Lower Harbor Rd., Brookings, OR 97415

Date: 04/04/2021
 Drawn By: INFRADRAFT
 Sheet No.: C-101
 File No.: 140

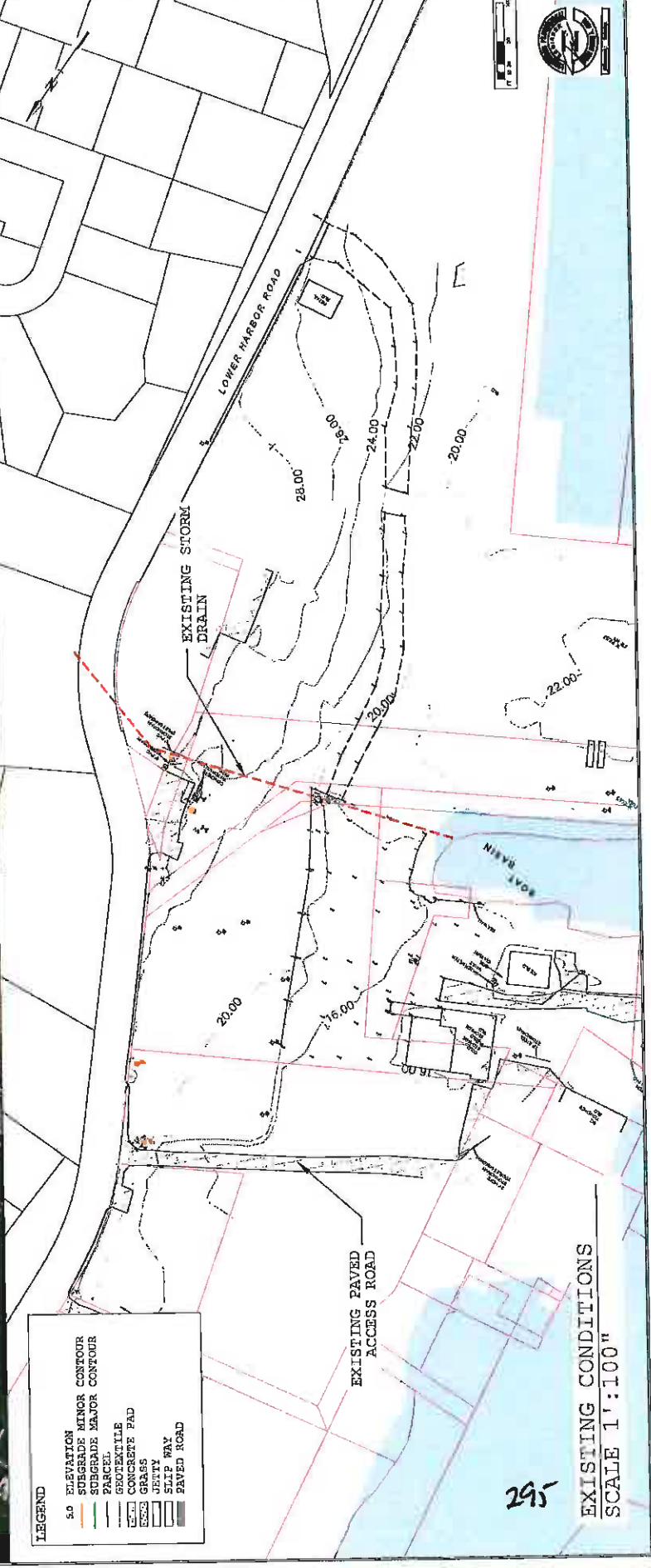

LEGEND

	5.0 ELEVATION
	SUBGRADE MINOR CONTOUR
	SUBGRADE MAJOR CONTOUR
	PARCEL
	GEOTEXTILE
	CONCRETE PAD
	GRASS
	JETTY PAV.
	PAVED ROAD

EXISTING PAVED ACCESS ROAD

295

EXISTING CONDITIONS
 SCALE 1"=100"



NO.	DATE	REVISION

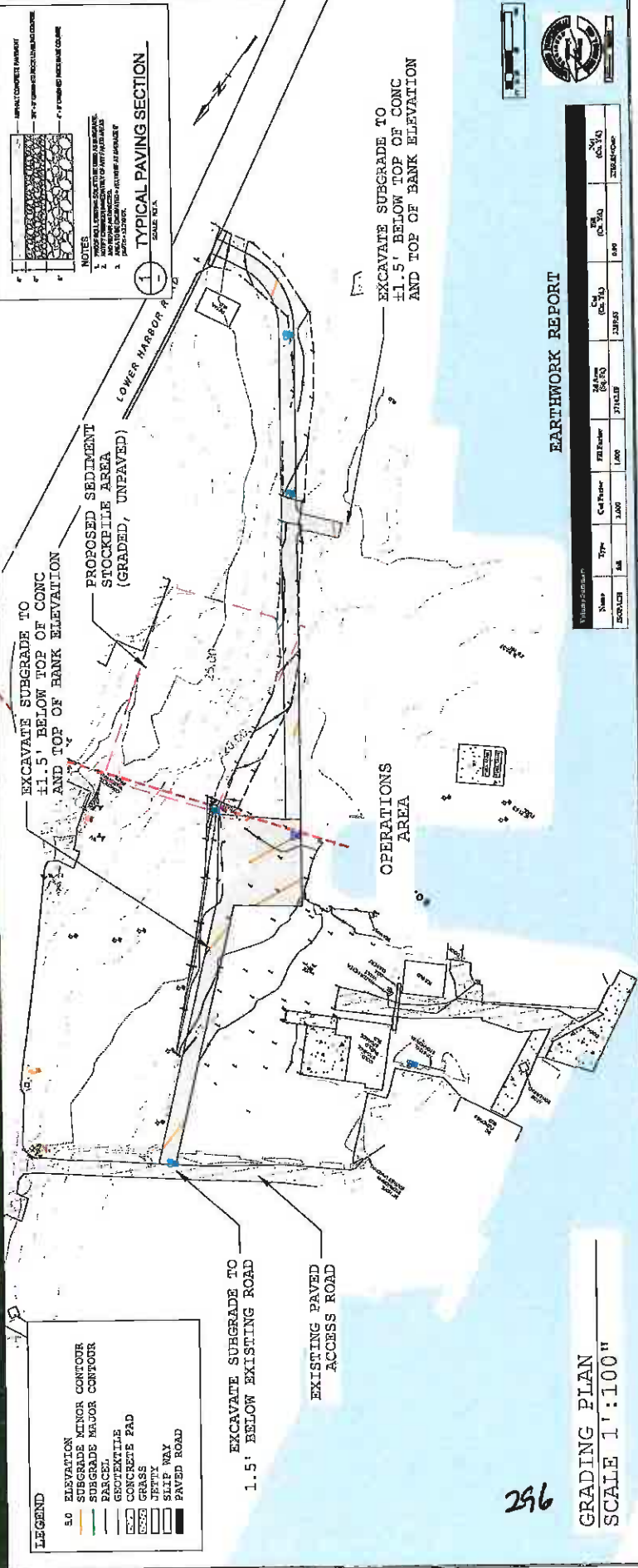

EARTHWORK REPORT

Name	Type	Cell Number	Area	Volume	Cost	Notes
Excavate	Excavate	1.000	17,143.00	1,100.00	2,000.00	
Fill	Fill	1.000	1,100.00	1,100.00	2,000.00	
Pave	Pave	1.000	1,100.00	1,100.00	2,000.00	
Grass	Grass	1.000	1,100.00	1,100.00	2,000.00	
Slip Rip	Slip Rip	1.000	1,100.00	1,100.00	2,000.00	
Paved Road	Paved Road	1.000	1,100.00	1,100.00	2,000.00	

296

GRADING PLAN
 SCALE 1"=100'

No.	DATE	REVISION



PORT OF BROOKINGS
 16330 Lower Harbor Rd, Brookings, OR 97415
 PREPARED FOR: (LOT 2900, MAP 38052208)

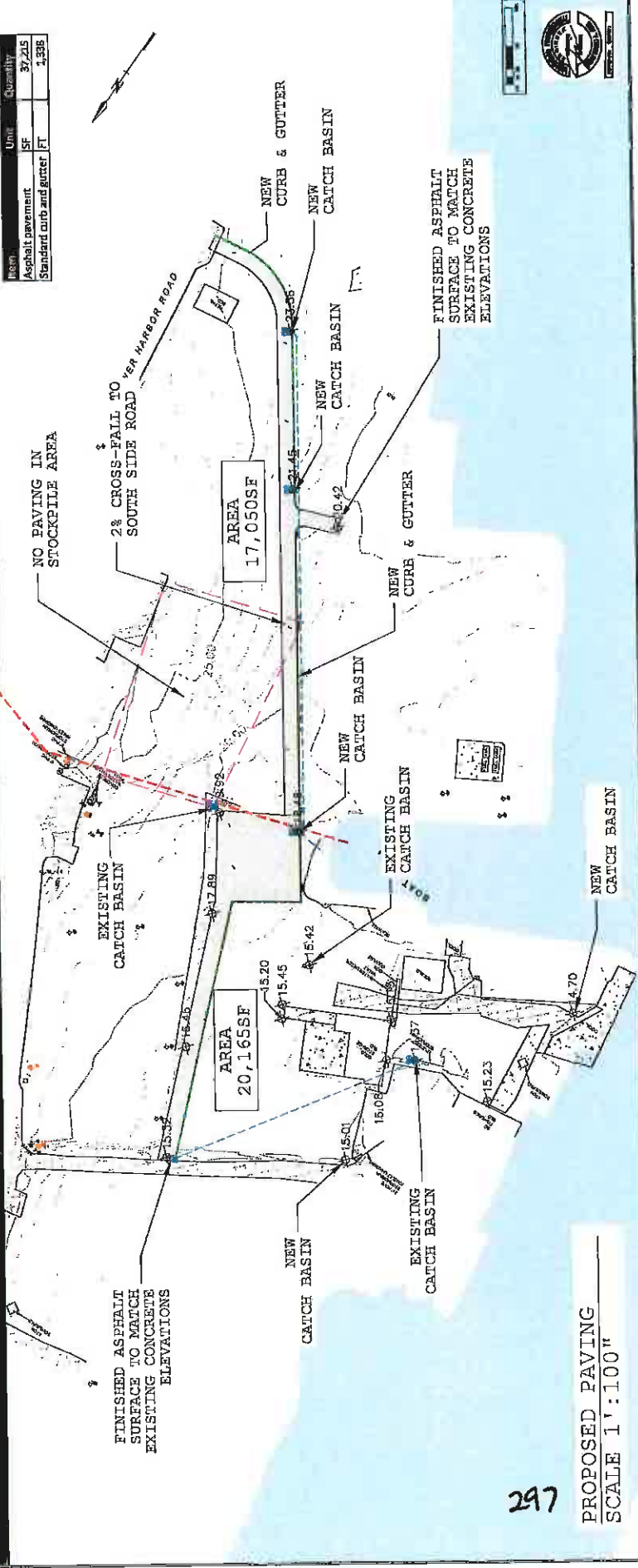

Item	Unit	Quantity
Asphalt pavement	SF	37,245
Standard curb and gutter	FT	1,338



FINISHED ASPHALT SURFACE TO MATCH EXISTING CONCRETE ELEVATIONS

FINISHED ASPHALT SURFACE TO MATCH EXISTING CONCRETE ELEVATIONS

PROPOSED PAVING SCALE 1"=100'

297

NO.	DATE	REVISION

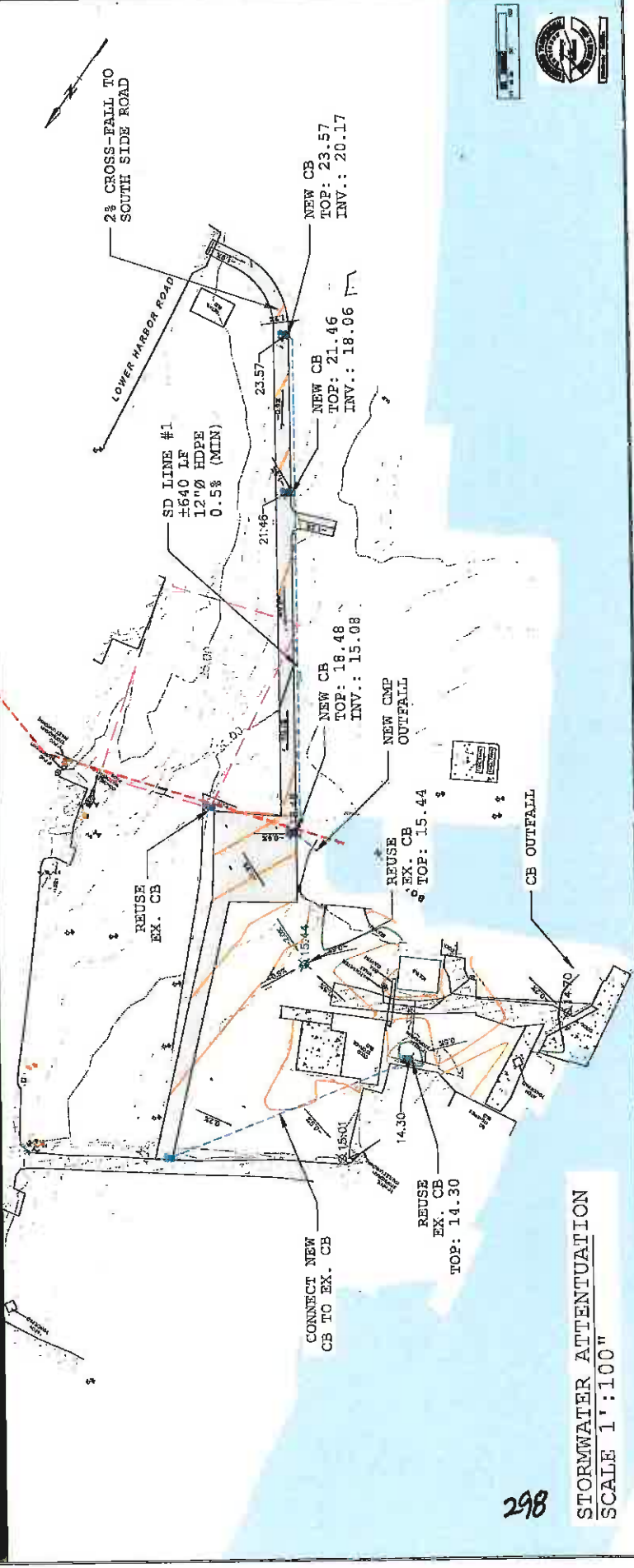

298

STORMWATER ATTENUATION
 SCALE 1" = 100'

NO.	DATE	REVISIONS

EMC
 Engineers/Scientists, LLC
 1000 NE Oregon Street, Suite 1100, Portland, OR 97232
 Phone: 503.251.1100 Fax: 503.251.1101
 Website: www.emc-engineers.com



PORT OF BROOKINGS HARBOR
 BOAT YARD PAVING
 16330 LOWER HARBOR ROAD, BROOKINGS, OR 97415

DRAWN BY: JG
 DATE: 11 MAY 2021
 JOB No: 21-001
 SHEET No: 4
C1.0
 COVER SHEET

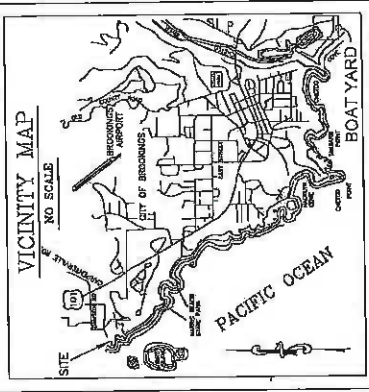

GRADING NOTES

1. PRIOR TO THE COMMENCEMENT OF EXCAVATION, THE CONTRACTOR SHALL EXAMINE THE EXISTING GRADE AND DETERMINE THE LOCATION AND DEPTH OF ALL EXISTING UTILITIES. THE CONTRACTOR SHALL BE RESPONSIBLE FOR THE PROTECTION OF ALL UTILITIES. THE CONTRACTOR SHALL BE RESPONSIBLE FOR THE PROTECTION OF ALL EXISTING UTILITIES. THE CONTRACTOR SHALL BE RESPONSIBLE FOR THE PROTECTION OF ALL EXISTING UTILITIES.
2. THE CONTRACTOR SHALL MAINTAIN THE EXISTING GRADE AND DETERMINE THE LOCATION AND DEPTH OF ALL EXISTING UTILITIES. THE CONTRACTOR SHALL BE RESPONSIBLE FOR THE PROTECTION OF ALL UTILITIES. THE CONTRACTOR SHALL BE RESPONSIBLE FOR THE PROTECTION OF ALL EXISTING UTILITIES.
3. THE CONTRACTOR SHALL MAINTAIN THE EXISTING GRADE AND DETERMINE THE LOCATION AND DEPTH OF ALL EXISTING UTILITIES. THE CONTRACTOR SHALL BE RESPONSIBLE FOR THE PROTECTION OF ALL UTILITIES. THE CONTRACTOR SHALL BE RESPONSIBLE FOR THE PROTECTION OF ALL EXISTING UTILITIES.
4. THE CONTRACTOR SHALL MAINTAIN THE EXISTING GRADE AND DETERMINE THE LOCATION AND DEPTH OF ALL EXISTING UTILITIES. THE CONTRACTOR SHALL BE RESPONSIBLE FOR THE PROTECTION OF ALL UTILITIES. THE CONTRACTOR SHALL BE RESPONSIBLE FOR THE PROTECTION OF ALL EXISTING UTILITIES.
5. THE CONTRACTOR SHALL MAINTAIN THE EXISTING GRADE AND DETERMINE THE LOCATION AND DEPTH OF ALL EXISTING UTILITIES. THE CONTRACTOR SHALL BE RESPONSIBLE FOR THE PROTECTION OF ALL UTILITIES. THE CONTRACTOR SHALL BE RESPONSIBLE FOR THE PROTECTION OF ALL EXISTING UTILITIES.
6. THE CONTRACTOR SHALL MAINTAIN THE EXISTING GRADE AND DETERMINE THE LOCATION AND DEPTH OF ALL EXISTING UTILITIES. THE CONTRACTOR SHALL BE RESPONSIBLE FOR THE PROTECTION OF ALL UTILITIES. THE CONTRACTOR SHALL BE RESPONSIBLE FOR THE PROTECTION OF ALL EXISTING UTILITIES.
7. THE CONTRACTOR SHALL MAINTAIN THE EXISTING GRADE AND DETERMINE THE LOCATION AND DEPTH OF ALL EXISTING UTILITIES. THE CONTRACTOR SHALL BE RESPONSIBLE FOR THE PROTECTION OF ALL UTILITIES. THE CONTRACTOR SHALL BE RESPONSIBLE FOR THE PROTECTION OF ALL EXISTING UTILITIES.
8. THE CONTRACTOR SHALL MAINTAIN THE EXISTING GRADE AND DETERMINE THE LOCATION AND DEPTH OF ALL EXISTING UTILITIES. THE CONTRACTOR SHALL BE RESPONSIBLE FOR THE PROTECTION OF ALL UTILITIES. THE CONTRACTOR SHALL BE RESPONSIBLE FOR THE PROTECTION OF ALL EXISTING UTILITIES.
9. THE CONTRACTOR SHALL MAINTAIN THE EXISTING GRADE AND DETERMINE THE LOCATION AND DEPTH OF ALL EXISTING UTILITIES. THE CONTRACTOR SHALL BE RESPONSIBLE FOR THE PROTECTION OF ALL UTILITIES. THE CONTRACTOR SHALL BE RESPONSIBLE FOR THE PROTECTION OF ALL EXISTING UTILITIES.
10. THE CONTRACTOR SHALL MAINTAIN THE EXISTING GRADE AND DETERMINE THE LOCATION AND DEPTH OF ALL EXISTING UTILITIES. THE CONTRACTOR SHALL BE RESPONSIBLE FOR THE PROTECTION OF ALL UTILITIES. THE CONTRACTOR SHALL BE RESPONSIBLE FOR THE PROTECTION OF ALL EXISTING UTILITIES.
11. THE CONTRACTOR SHALL MAINTAIN THE EXISTING GRADE AND DETERMINE THE LOCATION AND DEPTH OF ALL EXISTING UTILITIES. THE CONTRACTOR SHALL BE RESPONSIBLE FOR THE PROTECTION OF ALL UTILITIES. THE CONTRACTOR SHALL BE RESPONSIBLE FOR THE PROTECTION OF ALL EXISTING UTILITIES.
12. THE CONTRACTOR SHALL MAINTAIN THE EXISTING GRADE AND DETERMINE THE LOCATION AND DEPTH OF ALL EXISTING UTILITIES. THE CONTRACTOR SHALL BE RESPONSIBLE FOR THE PROTECTION OF ALL UTILITIES. THE CONTRACTOR SHALL BE RESPONSIBLE FOR THE PROTECTION OF ALL EXISTING UTILITIES.
13. THE CONTRACTOR SHALL MAINTAIN THE EXISTING GRADE AND DETERMINE THE LOCATION AND DEPTH OF ALL EXISTING UTILITIES. THE CONTRACTOR SHALL BE RESPONSIBLE FOR THE PROTECTION OF ALL UTILITIES. THE CONTRACTOR SHALL BE RESPONSIBLE FOR THE PROTECTION OF ALL EXISTING UTILITIES.

GEOTECHNICAL NOTE

THE CONTRACTOR SHALL COORDINATE CONSTRUCTION ACTIVITIES WITH THE PROJECT ENGINEER FOR REMEDIATION AND CONSTRUCTION OF ALL UTILITIES. THE CONTRACTOR SHALL BE RESPONSIBLE FOR THE PROTECTION OF ALL UTILITIES. THE CONTRACTOR SHALL BE RESPONSIBLE FOR THE PROTECTION OF ALL EXISTING UTILITIES.

SHEET INDEX

C1.0	COVER SHEET
C2.0	GENERAL NOTES
C2.1	GRADING PLAN
C2.2	PAVING PLAN
C2.3	PAVEMENT AREA
C2.4	STORMWATER DRAINAGE PROFILE
C2.5	NOT USED
C2.6	PROJECT DETAILS
C2.7	PROJECT DETAILS



NO.	DATE	BY

EMC
Engineers/Scientists, LLC
Grain Processing • Jacksonville • Medford, OR
The McGraw-Hill Companies • 1221 Avenue of the Americas • New York, NY 10020
Tel: 212-512-2000 • Fax: 212-512-2001
www.emc-engineers.com



PORT OF BROOKINGS HARBOR
BOAT YARD PAVING
16338 LOWER HARBOR ROAD, BROOKINGS, OR 97415

DRAWN BY: JG
DATE: 11 MAY 2021
JOB NO.:
SHEET NO.:
C2.0
EXISTING
CONDITIONS

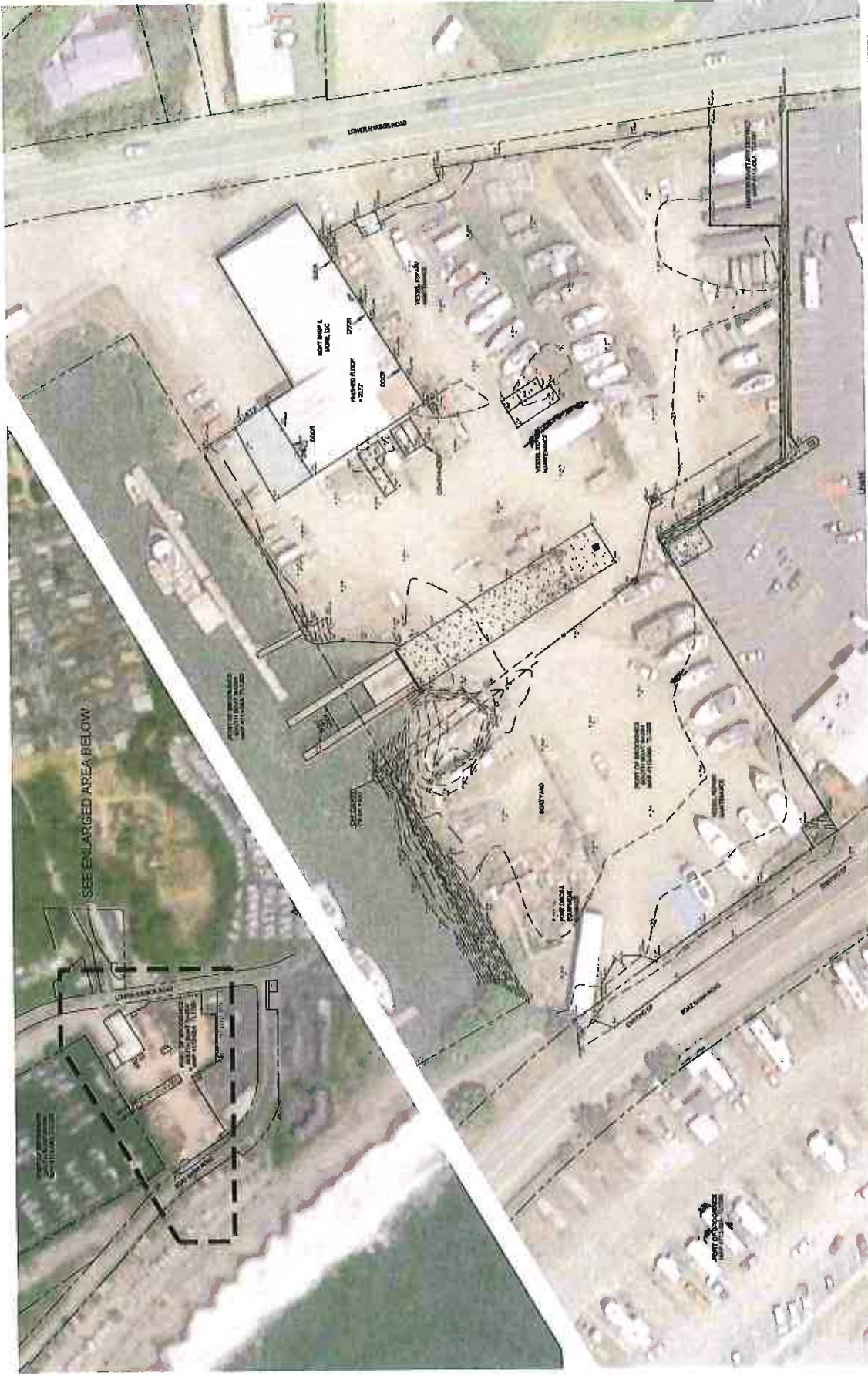

SEE ENLARGED AREA BELOW



EXISTING CONDITIONS
SCALE: 1" = 30' (PLAN)



VERTICAL DATUM
ELEVATIONS ARE IN FEET ABOVE MEAN SEA LEVEL
AS DETERMINED BY THE NATIONAL TIDE DATUM
ESTABLISHED IN 1985

HORIZONTAL DATUM
ELEVATIONS ARE IN FEET ABOVE MEAN SEA LEVEL
AS DETERMINED BY THE NATIONAL TIDE DATUM
ESTABLISHED IN 1985

SURVEY BY
EMC ENGINEERS/SCIENTISTS, LLC
11/15/2020

NO.	DATE	BY	REVISIONS

EMC
 Engineers/Scientists, LLC
 Great Falls • Jacksonville • Madison • Memphis, TN
 2150 Riverchase Circle, Suite 100, Jacksonville, FL 32217
 Phone: 904-383-7222 • Fax: 904-383-7228
 E-mail: info@emc-engineers.com • www.emc-engineers.com



PORT OF BROOKINGS HARBOR
 BOAT YARD PAVING
 16330 LOWER HARBOR ROAD, BROOKINGS, OR 97415

DRAWN BY: JS
 DATE: 11 MAY 2021
 JOB NO: 21-001
 SHEET NO: 2
C2.2
 FINISHED PAVING PLAN

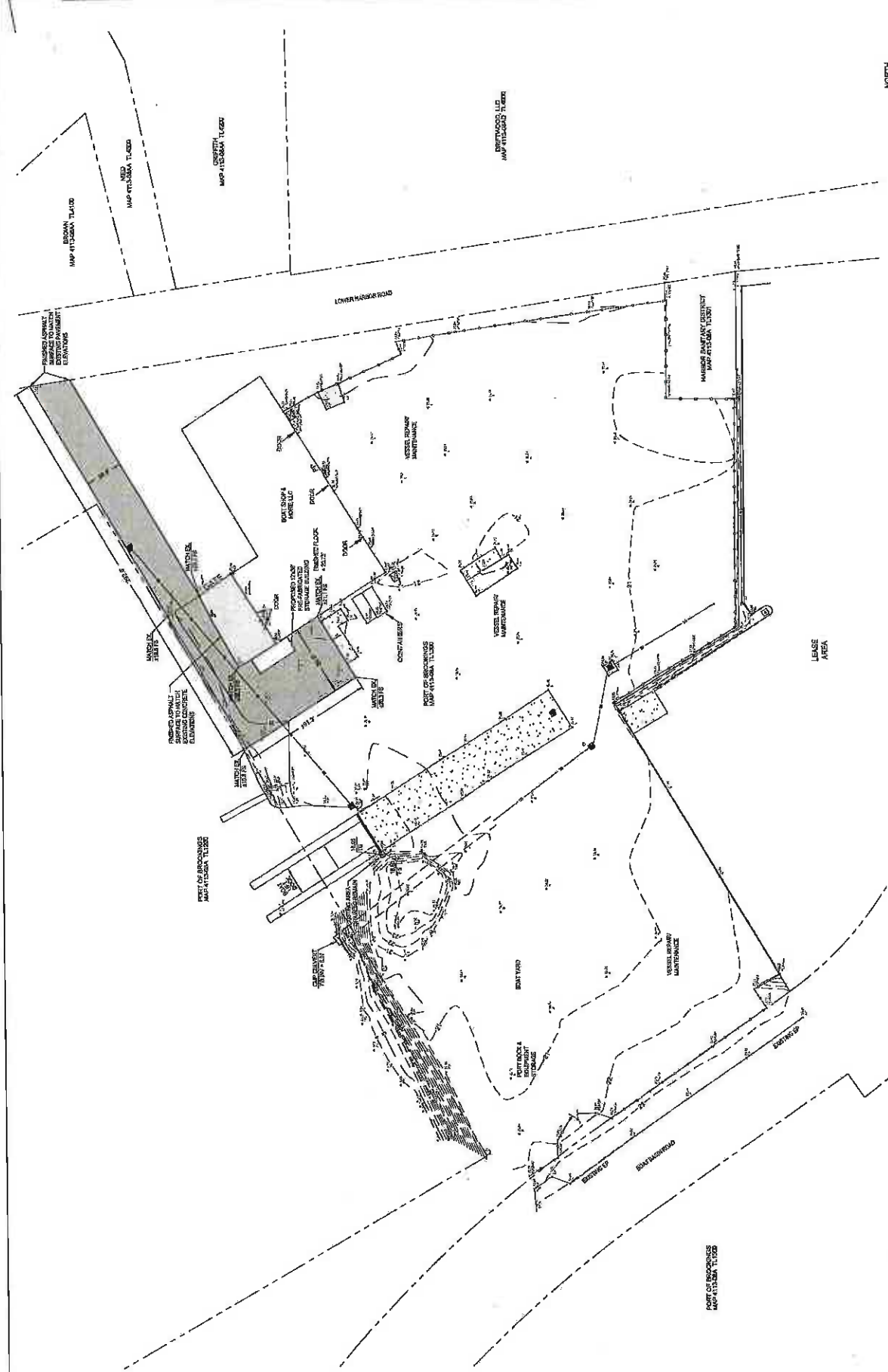

FINISHED PAVING PLAN
 SCALE: 1" = 30'



PORT OF BROOKINGS HARBOR
BOAT YARD PAVING

16330 LOWER HARBOR ROAD, BROOKINGS, OR 97415

DESIGNED BY:	JCS
DATE:	11 MAY 2021
JOB NO.:	11
SHEET NO.:	C3.0
PAVEMENT AREAS	



REVISIONS	BY:

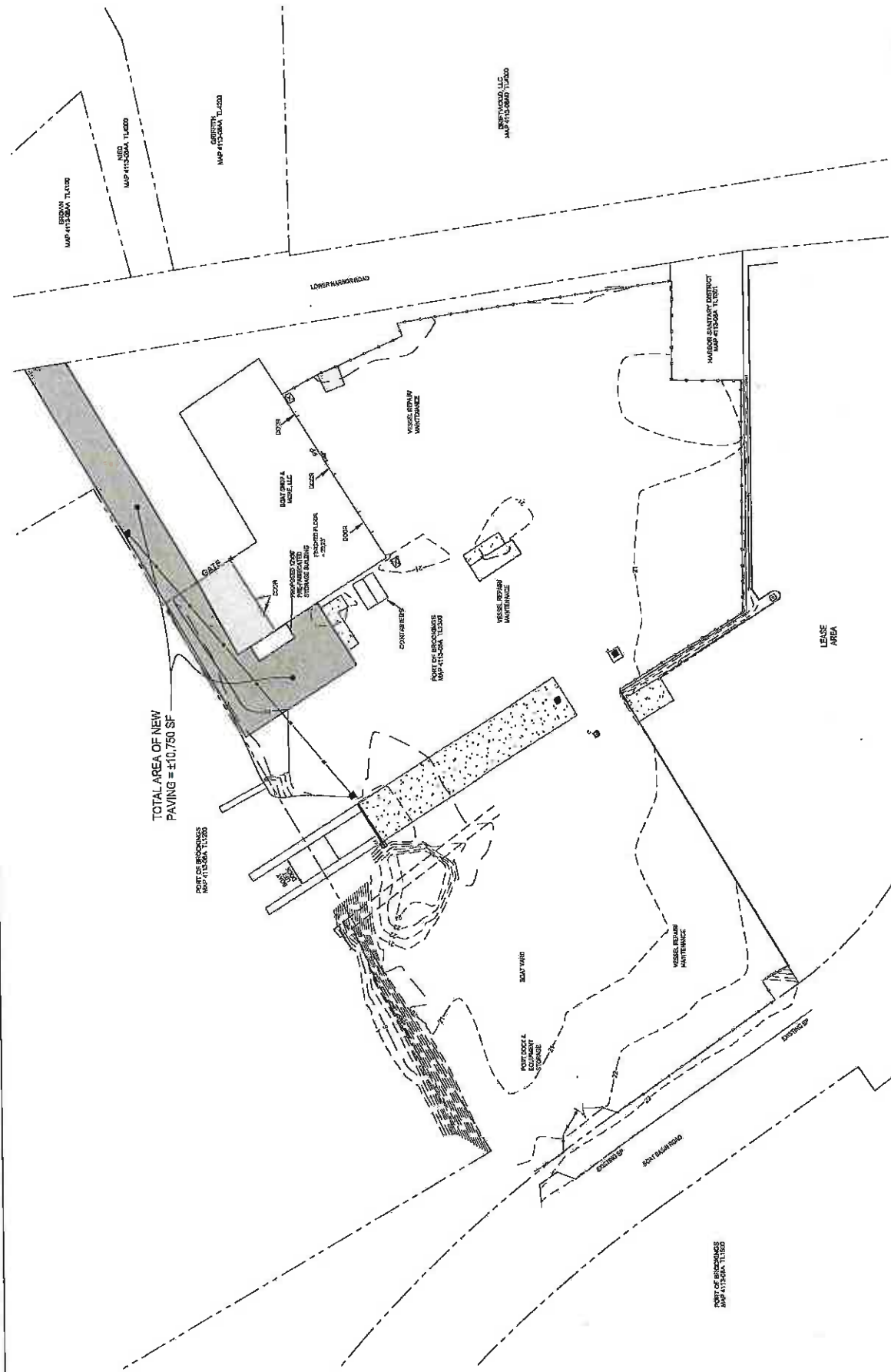

REVISIONS	BY

EMC
 Engineers/Scientists, LLC
 1000 North Carolina Street, Suite 200
 Raleigh, NC 27601
 Phone: 919.978.1234
 Fax: 919.978.1235
 Email: info@emc-engineers.com



PORT OF BROOKINGS HARBOR
 BOAT YARD PAVING
 16330 LOWER HARBOR ROAD, BROOKINGS, OR 97415

DRAWN BY: JG
 DATE: 11 MAY 2021
 SHEET NO: C4.0
 STORMWATER CONVEYANCE

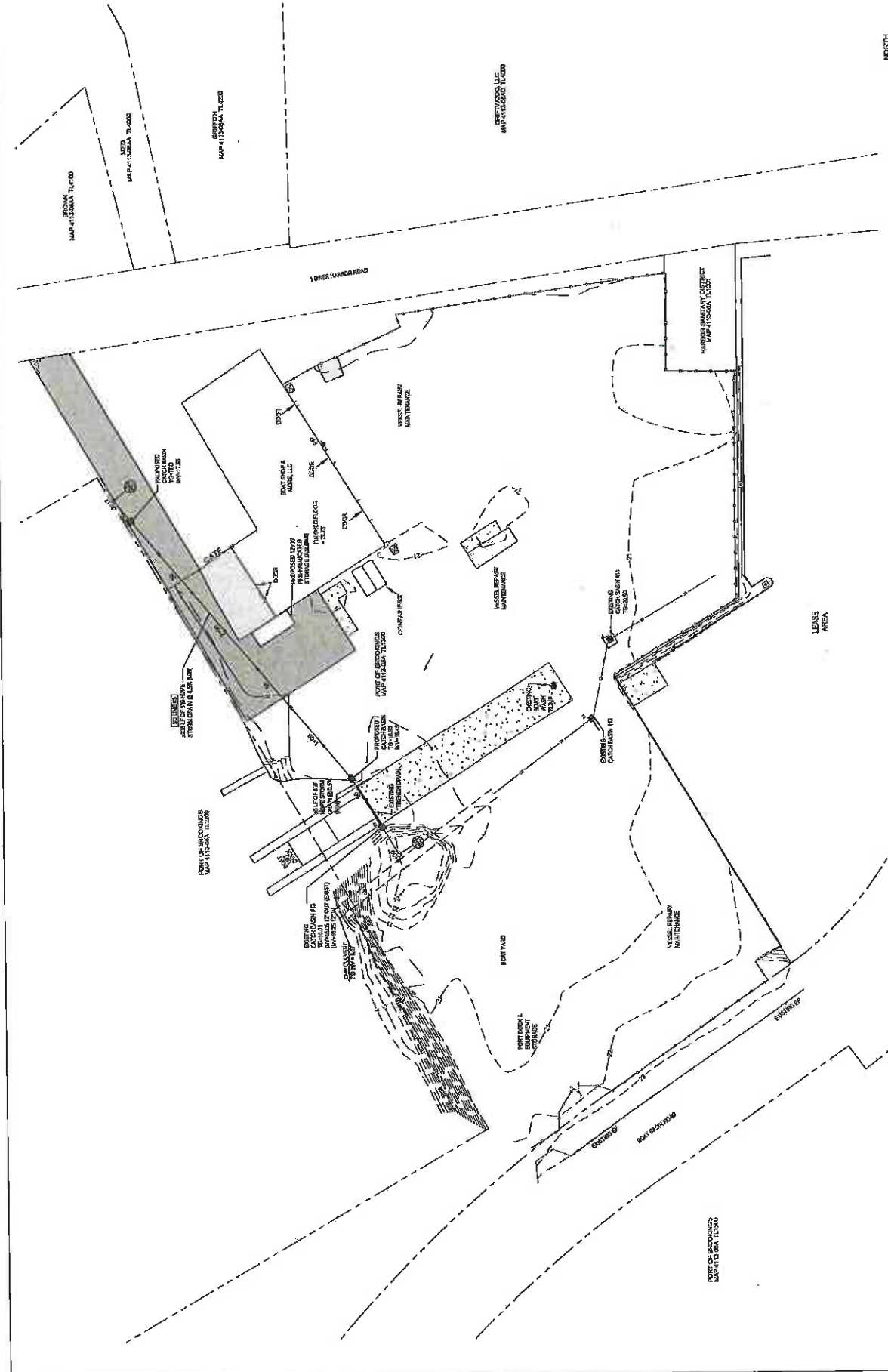

STORMWATER CONVEYANCE
 SCALE: 1" = 20'



505

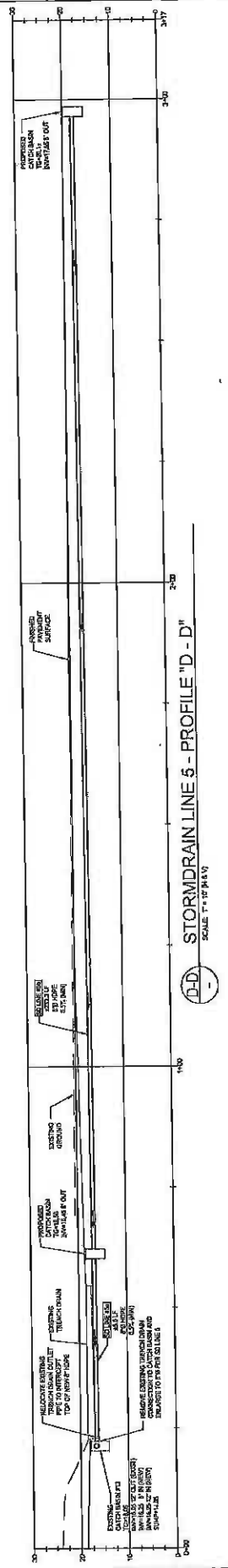

D-D
 STORMDRAIN LINE 5 - PROFILE "D - D"
 SCALE 1" = 10' H&V

PORT OF BROOKINGS HARBOR
 BOAT YARD PAVING
 16330 LOWER HARBOR ROAD, BROOKINGS, OR 97415



EMC
 Engineers/Scientists, LLC
 1000 NE Oregon Street, Suite 200, Medford, OR 97504
 541-754-9900 • Fax 541-754-9901
 1000 NE Oregon Street, Suite 200, Medford, OR 97504
 541-754-9900 • Fax 541-754-9901

DRAWN BY: JG
 DATE: 11 MAY 2021
 JOB No: 2
 SHEET No: 2
 CA.1
 STORMDRAIN
 PROFILES

NO.	REVISIONS	BY:

REVISIONS	BY:

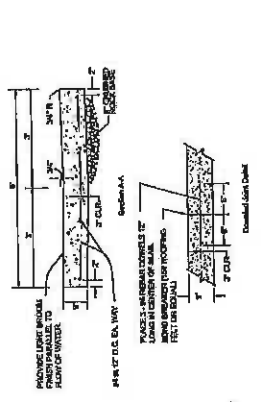
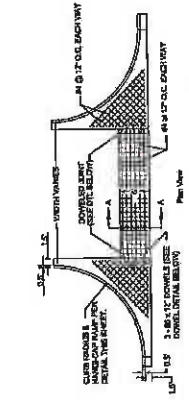

NOTES
1. ALL CONCRETE SHALL BE CAST IN PLACE AND SHALL BE FINISHED TO MATCH ADJACENT DRIVEWAY SURFACE.
2. SUBGRADE SHALL BE 4\"/>

200 DRIVEWAY APRON WITH VALLEY GUTTER
SCALE: 1/8\"/>

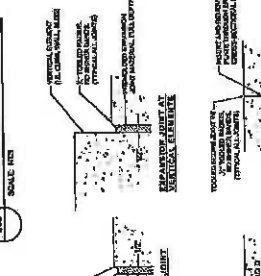
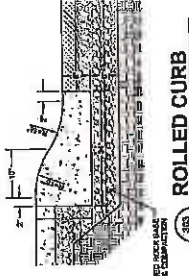

NOTES
1. CURB SHALL BE CAST IN PLACE AND SHALL BE FINISHED TO MATCH ADJACENT DRIVEWAY SURFACE.
2. SUBGRADE SHALL BE 4\"/>

210 ROLLED CURB
SCALE: 1/8\"/>

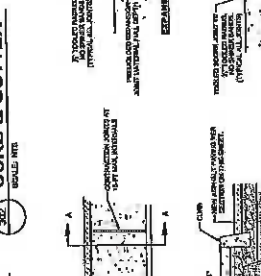
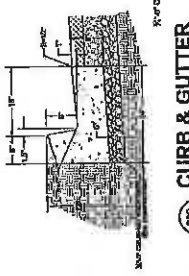

NOTES
1. CURB SHALL BE CAST IN PLACE AND SHALL BE FINISHED TO MATCH ADJACENT DRIVEWAY SURFACE.
2. SUBGRADE SHALL BE 4\"/>

220 CURB & GUTTER
SCALE: 1/8\"/>

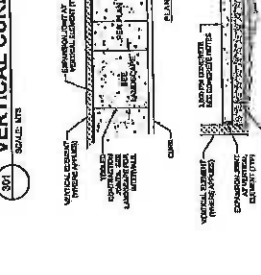
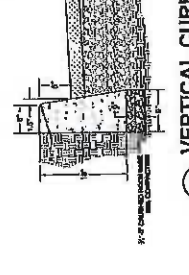

NOTES
1. CURB SHALL BE CAST IN PLACE AND SHALL BE FINISHED TO MATCH ADJACENT DRIVEWAY SURFACE.
2. SUBGRADE SHALL BE 4\"/>

230 VERTICAL CURB
SCALE: 1/8\"/>

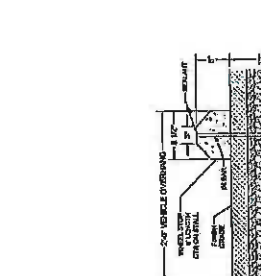

NOTES
1. CURB LINE SHALL BE CAST IN PLACE AND SHALL BE FINISHED TO MATCH ADJACENT DRIVEWAY SURFACE.
2. SUBGRADE SHALL BE 4\"/>

240 CURB LINE CONCRETE SIDEWALK
SCALE: 1/8\"/>



NOTES
1. WHEEL STOP SHALL BE CAST IN PLACE AND SHALL BE FINISHED TO MATCH ADJACENT DRIVEWAY SURFACE.
2. SUBGRADE SHALL BE 4\"/>

250 WHEEL STOP
SCALE: 1/8\"/>

NOTES
1. CURB TAPER SHALL BE CAST IN PLACE AND SHALL BE FINISHED TO MATCH ADJACENT DRIVEWAY SURFACE.
2. SUBGRADE SHALL BE 4\"/>

260 CURB TAPER
SCALE: 1/8\"/>

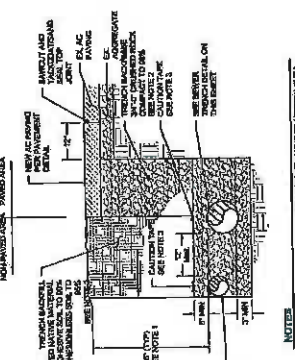

NOTES
1. JOINT TRENCH SHALL BE CAST IN PLACE AND SHALL BE FINISHED TO MATCH ADJACENT DRIVEWAY SURFACE.
2. SUBGRADE SHALL BE 4\"/>

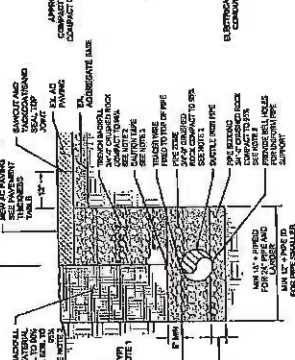

270 JOINT TRENCH DETAIL
SCALE: 1/8\"/>

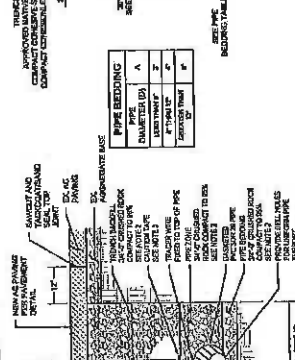

NOTES
1. WATER TRENCH SHALL BE CAST IN PLACE AND SHALL BE FINISHED TO MATCH ADJACENT DRIVEWAY SURFACE.
2. SUBGRADE SHALL BE 4\"/>

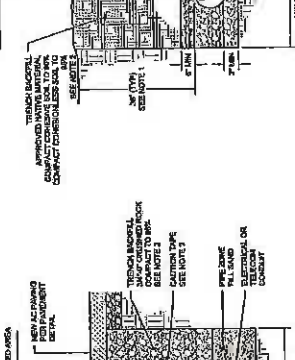

280 WATER TRENCH DETAIL
SCALE: 1/8\"/>

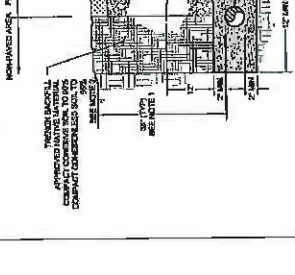

NOTES
1. SEWER TRENCH SHALL BE CAST IN PLACE AND SHALL BE FINISHED TO MATCH ADJACENT DRIVEWAY SURFACE.
2. SUBGRADE SHALL BE 4\"/>

290 SEWER TRENCH DETAIL
SCALE: 1/8\"/>

NOTES
1. CONDUIT TRENCH SHALL BE CAST IN PLACE AND SHALL BE FINISHED TO MATCH ADJACENT DRIVEWAY SURFACE.
2. SUBGRADE SHALL BE 4\"/>

300 CONDUIT TRENCH DETAIL
SCALE: 1/8\"/>

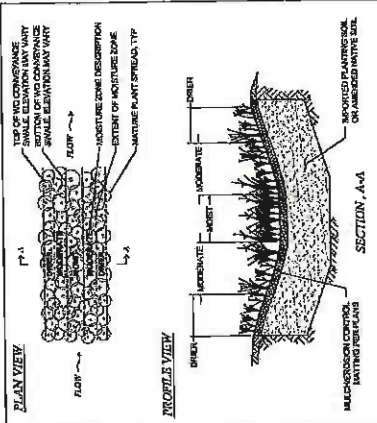

LEGEND

- 1. MULCH
- 2. GEOTEXTILE
- 3. SOIL
- 4. PLANT
- 5. SUBGRADE

NOTES

1. DETAILS PROVIDED AS A SCHEMATIC EXAMPLE OF THE PROPOSED VEGETATED PARKING AREA.
2. MULCH SHALL BE FINE GRADED MULCH, 4" MINIMUM DEPTH, AND SHALL BE COVERED WITH 2" OF COMPOST OR OTHER ORGANIC MATERIAL.
3. GEOTEXTILE SHALL BE 20 OZ/SYD WOVEN POLYESTER NONWOVEN GEOTEXTILE.
4. SOIL SHALL BE 2" MINIMUM DEPTH OF TOPSOIL.
5. PLANTS SHALL BE 1" MINIMUM TALL, NON-TOXIC, AND SUITABLE FOR THE CLIMATE AND SOIL TYPE.
6. MULCH SHALL BE COVERED WITH 2" OF COMPOST OR OTHER ORGANIC MATERIAL.
7. SUBGRADE SHALL BE 4" MINIMUM DEPTH OF COMPACTED SUBGRADE.
8. VEGETATION SHALL BE MAINTAINED AT ALL TIMES.
9. MULCH SHALL BE MAINTAINED AT ALL TIMES.
10. GEOTEXTILE SHALL BE MAINTAINED AT ALL TIMES.
11. SOIL SHALL BE MAINTAINED AT ALL TIMES.
12. PLANTS SHALL BE MAINTAINED AT ALL TIMES.
13. SUBGRADE SHALL BE MAINTAINED AT ALL TIMES.

Regan Valley Water Quality Conveyance Swale
 Planning Schematics
 Manual
 BMP 6.03
 Scale: NTS
 1 of 1

General Notes for Vegetated parking

1. Details provided as a schematic example of the proposed vegetated parking area.
2. Details provided as a schematic example of the proposed vegetated parking area.
3. Details provided as a schematic example of the proposed vegetated parking area.
4. Details provided as a schematic example of the proposed vegetated parking area.
5. Details provided as a schematic example of the proposed vegetated parking area.
6. Details provided as a schematic example of the proposed vegetated parking area.
7. Details provided as a schematic example of the proposed vegetated parking area.
8. Details provided as a schematic example of the proposed vegetated parking area.
9. Details provided as a schematic example of the proposed vegetated parking area.
10. Details provided as a schematic example of the proposed vegetated parking area.
11. Details provided as a schematic example of the proposed vegetated parking area.
12. Details provided as a schematic example of the proposed vegetated parking area.
13. Details provided as a schematic example of the proposed vegetated parking area.
14. Details provided as a schematic example of the proposed vegetated parking area.
15. Details provided as a schematic example of the proposed vegetated parking area.
16. Details provided as a schematic example of the proposed vegetated parking area.
17. Details provided as a schematic example of the proposed vegetated parking area.
18. Details provided as a schematic example of the proposed vegetated parking area.
19. Details provided as a schematic example of the proposed vegetated parking area.
20. Details provided as a schematic example of the proposed vegetated parking area.

SWALE SCHEDULE

SWALE TYPE	SWALE WIDTH	SWALE DEPTH	SWALE LENGTH	SWALE SPACING
SWALE 1	10'	6"	10'	10'
SWALE 2	10'	6"	10'	10'
SWALE 3	10'	6"	10'	10'
SWALE 4	10'	6"	10'	10'
SWALE 5	10'	6"	10'	10'
SWALE 6	10'	6"	10'	10'
SWALE 7	10'	6"	10'	10'
SWALE 8	10'	6"	10'	10'
SWALE 9	10'	6"	10'	10'
SWALE 10	10'	6"	10'	10'

NOTES

1. SWALE SCHEDULE SHALL BE CONFORM TO REQUIREMENTS OF LOCAL CODE.
2. SWALE SCHEDULE SHALL BE CONFORM TO REQUIREMENTS OF LOCAL CODE.
3. SWALE SCHEDULE SHALL BE CONFORM TO REQUIREMENTS OF LOCAL CODE.
4. SWALE SCHEDULE SHALL BE CONFORM TO REQUIREMENTS OF LOCAL CODE.
5. SWALE SCHEDULE SHALL BE CONFORM TO REQUIREMENTS OF LOCAL CODE.
6. SWALE SCHEDULE SHALL BE CONFORM TO REQUIREMENTS OF LOCAL CODE.
7. SWALE SCHEDULE SHALL BE CONFORM TO REQUIREMENTS OF LOCAL CODE.
8. SWALE SCHEDULE SHALL BE CONFORM TO REQUIREMENTS OF LOCAL CODE.
9. SWALE SCHEDULE SHALL BE CONFORM TO REQUIREMENTS OF LOCAL CODE.
10. SWALE SCHEDULE SHALL BE CONFORM TO REQUIREMENTS OF LOCAL CODE.
11. SWALE SCHEDULE SHALL BE CONFORM TO REQUIREMENTS OF LOCAL CODE.
12. SWALE SCHEDULE SHALL BE CONFORM TO REQUIREMENTS OF LOCAL CODE.
13. SWALE SCHEDULE SHALL BE CONFORM TO REQUIREMENTS OF LOCAL CODE.
14. SWALE SCHEDULE SHALL BE CONFORM TO REQUIREMENTS OF LOCAL CODE.
15. SWALE SCHEDULE SHALL BE CONFORM TO REQUIREMENTS OF LOCAL CODE.
16. SWALE SCHEDULE SHALL BE CONFORM TO REQUIREMENTS OF LOCAL CODE.
17. SWALE SCHEDULE SHALL BE CONFORM TO REQUIREMENTS OF LOCAL CODE.
18. SWALE SCHEDULE SHALL BE CONFORM TO REQUIREMENTS OF LOCAL CODE.
19. SWALE SCHEDULE SHALL BE CONFORM TO REQUIREMENTS OF LOCAL CODE.
20. SWALE SCHEDULE SHALL BE CONFORM TO REQUIREMENTS OF LOCAL CODE.

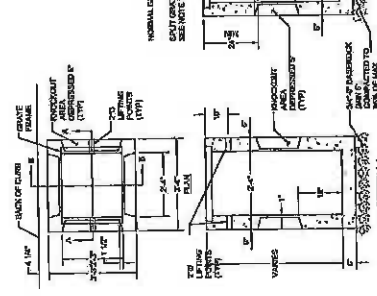

CATCH BASIN
 Scale: NTS

NOTES

1. CATCH BASIN SHALL BE CONSTRUCTED OF CONCRETE.
2. CATCH BASIN SHALL BE CONSTRUCTED OF CONCRETE.
3. CATCH BASIN SHALL BE CONSTRUCTED OF CONCRETE.
4. CATCH BASIN SHALL BE CONSTRUCTED OF CONCRETE.
5. CATCH BASIN SHALL BE CONSTRUCTED OF CONCRETE.
6. CATCH BASIN SHALL BE CONSTRUCTED OF CONCRETE.
7. CATCH BASIN SHALL BE CONSTRUCTED OF CONCRETE.
8. CATCH BASIN SHALL BE CONSTRUCTED OF CONCRETE.
9. CATCH BASIN SHALL BE CONSTRUCTED OF CONCRETE.
10. CATCH BASIN SHALL BE CONSTRUCTED OF CONCRETE.
11. CATCH BASIN SHALL BE CONSTRUCTED OF CONCRETE.
12. CATCH BASIN SHALL BE CONSTRUCTED OF CONCRETE.
13. CATCH BASIN SHALL BE CONSTRUCTED OF CONCRETE.
14. CATCH BASIN SHALL BE CONSTRUCTED OF CONCRETE.
15. CATCH BASIN SHALL BE CONSTRUCTED OF CONCRETE.
16. CATCH BASIN SHALL BE CONSTRUCTED OF CONCRETE.
17. CATCH BASIN SHALL BE CONSTRUCTED OF CONCRETE.
18. CATCH BASIN SHALL BE CONSTRUCTED OF CONCRETE.
19. CATCH BASIN SHALL BE CONSTRUCTED OF CONCRETE.
20. CATCH BASIN SHALL BE CONSTRUCTED OF CONCRETE.

LYNCH STYLE CATCH BASIN
 Scale: NTS

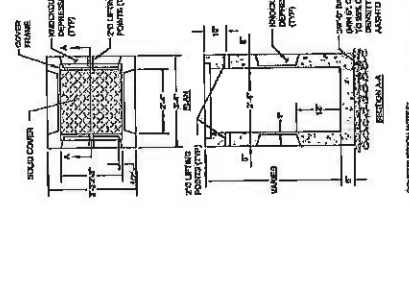

NOTES

1. LYNCH STYLE CATCH BASIN SHALL BE CONSTRUCTED OF CONCRETE.
2. LYNCH STYLE CATCH BASIN SHALL BE CONSTRUCTED OF CONCRETE.
3. LYNCH STYLE CATCH BASIN SHALL BE CONSTRUCTED OF CONCRETE.
4. LYNCH STYLE CATCH BASIN SHALL BE CONSTRUCTED OF CONCRETE.
5. LYNCH STYLE CATCH BASIN SHALL BE CONSTRUCTED OF CONCRETE.
6. LYNCH STYLE CATCH BASIN SHALL BE CONSTRUCTED OF CONCRETE.
7. LYNCH STYLE CATCH BASIN SHALL BE CONSTRUCTED OF CONCRETE.
8. LYNCH STYLE CATCH BASIN SHALL BE CONSTRUCTED OF CONCRETE.
9. LYNCH STYLE CATCH BASIN SHALL BE CONSTRUCTED OF CONCRETE.
10. LYNCH STYLE CATCH BASIN SHALL BE CONSTRUCTED OF CONCRETE.
11. LYNCH STYLE CATCH BASIN SHALL BE CONSTRUCTED OF CONCRETE.
12. LYNCH STYLE CATCH BASIN SHALL BE CONSTRUCTED OF CONCRETE.
13. LYNCH STYLE CATCH BASIN SHALL BE CONSTRUCTED OF CONCRETE.
14. LYNCH STYLE CATCH BASIN SHALL BE CONSTRUCTED OF CONCRETE.
15. LYNCH STYLE CATCH BASIN SHALL BE CONSTRUCTED OF CONCRETE.
16. LYNCH STYLE CATCH BASIN SHALL BE CONSTRUCTED OF CONCRETE.
17. LYNCH STYLE CATCH BASIN SHALL BE CONSTRUCTED OF CONCRETE.
18. LYNCH STYLE CATCH BASIN SHALL BE CONSTRUCTED OF CONCRETE.
19. LYNCH STYLE CATCH BASIN SHALL BE CONSTRUCTED OF CONCRETE.
20. LYNCH STYLE CATCH BASIN SHALL BE CONSTRUCTED OF CONCRETE.

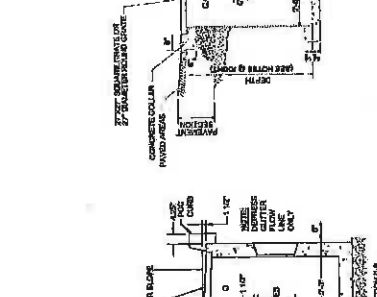

48" STORM MANHOLE
 Scale: NTS

NOTES

1. 48" STORM MANHOLE SHALL BE CONSTRUCTED OF CONCRETE.
2. 48" STORM MANHOLE SHALL BE CONSTRUCTED OF CONCRETE.
3. 48" STORM MANHOLE SHALL BE CONSTRUCTED OF CONCRETE.
4. 48" STORM MANHOLE SHALL BE CONSTRUCTED OF CONCRETE.
5. 48" STORM MANHOLE SHALL BE CONSTRUCTED OF CONCRETE.
6. 48" STORM MANHOLE SHALL BE CONSTRUCTED OF CONCRETE.
7. 48" STORM MANHOLE SHALL BE CONSTRUCTED OF CONCRETE.
8. 48" STORM MANHOLE SHALL BE CONSTRUCTED OF CONCRETE.
9. 48" STORM MANHOLE SHALL BE CONSTRUCTED OF CONCRETE.
10. 48" STORM MANHOLE SHALL BE CONSTRUCTED OF CONCRETE.
11. 48" STORM MANHOLE SHALL BE CONSTRUCTED OF CONCRETE.
12. 48" STORM MANHOLE SHALL BE CONSTRUCTED OF CONCRETE.
13. 48" STORM MANHOLE SHALL BE CONSTRUCTED OF CONCRETE.
14. 48" STORM MANHOLE SHALL BE CONSTRUCTED OF CONCRETE.
15. 48" STORM MANHOLE SHALL BE CONSTRUCTED OF CONCRETE.
16. 48" STORM MANHOLE SHALL BE CONSTRUCTED OF CONCRETE.
17. 48" STORM MANHOLE SHALL BE CONSTRUCTED OF CONCRETE.
18. 48" STORM MANHOLE SHALL BE CONSTRUCTED OF CONCRETE.
19. 48" STORM MANHOLE SHALL BE CONSTRUCTED OF CONCRETE.
20. 48" STORM MANHOLE SHALL BE CONSTRUCTED OF CONCRETE.

CONTROL STRUCTURE MANHOLE
 Scale: NTS

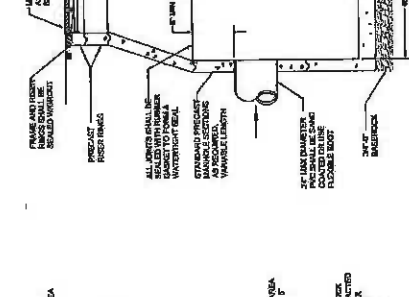

NOTES

1. CONTROL STRUCTURE MANHOLE SHALL BE CONSTRUCTED OF CONCRETE.
2. CONTROL STRUCTURE MANHOLE SHALL BE CONSTRUCTED OF CONCRETE.
3. CONTROL STRUCTURE MANHOLE SHALL BE CONSTRUCTED OF CONCRETE.
4. CONTROL STRUCTURE MANHOLE SHALL BE CONSTRUCTED OF CONCRETE.
5. CONTROL STRUCTURE MANHOLE SHALL BE CONSTRUCTED OF CONCRETE.
6. CONTROL STRUCTURE MANHOLE SHALL BE CONSTRUCTED OF CONCRETE.
7. CONTROL STRUCTURE MANHOLE SHALL BE CONSTRUCTED OF CONCRETE.
8. CONTROL STRUCTURE MANHOLE SHALL BE CONSTRUCTED OF CONCRETE.
9. CONTROL STRUCTURE MANHOLE SHALL BE CONSTRUCTED OF CONCRETE.
10. CONTROL STRUCTURE MANHOLE SHALL BE CONSTRUCTED OF CONCRETE.
11. CONTROL STRUCTURE MANHOLE SHALL BE CONSTRUCTED OF CONCRETE.
12. CONTROL STRUCTURE MANHOLE SHALL BE CONSTRUCTED OF CONCRETE.
13. CONTROL STRUCTURE MANHOLE SHALL BE CONSTRUCTED OF CONCRETE.
14. CONTROL STRUCTURE MANHOLE SHALL BE CONSTRUCTED OF CONCRETE.
15. CONTROL STRUCTURE MANHOLE SHALL BE CONSTRUCTED OF CONCRETE.
16. CONTROL STRUCTURE MANHOLE SHALL BE CONSTRUCTED OF CONCRETE.
17. CONTROL STRUCTURE MANHOLE SHALL BE CONSTRUCTED OF CONCRETE.
18. CONTROL STRUCTURE MANHOLE SHALL BE CONSTRUCTED OF CONCRETE.
19. CONTROL STRUCTURE MANHOLE SHALL BE CONSTRUCTED OF CONCRETE.
20. CONTROL STRUCTURE MANHOLE SHALL BE CONSTRUCTED OF CONCRETE.

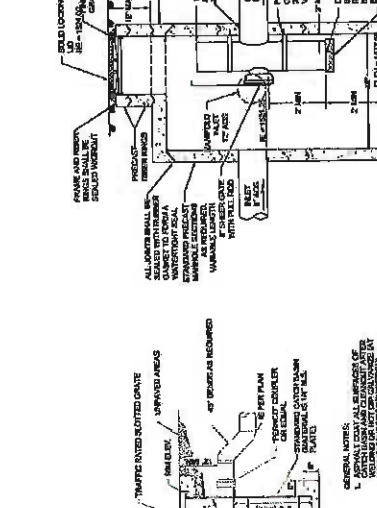

TYPICAL CLEANOUT
 Scale: NTS

NOTES

1. TYPICAL CLEANOUT SHALL BE CONFORM TO REQUIREMENTS OF LOCAL CODE.
2. TYPICAL CLEANOUT SHALL BE CONFORM TO REQUIREMENTS OF LOCAL CODE.
3. TYPICAL CLEANOUT SHALL BE CONFORM TO REQUIREMENTS OF LOCAL CODE.
4. TYPICAL CLEANOUT SHALL BE CONFORM TO REQUIREMENTS OF LOCAL CODE.
5. TYPICAL CLEANOUT SHALL BE CONFORM TO REQUIREMENTS OF LOCAL CODE.
6. TYPICAL CLEANOUT SHALL BE CONFORM TO REQUIREMENTS OF LOCAL CODE.
7. TYPICAL CLEANOUT SHALL BE CONFORM TO REQUIREMENTS OF LOCAL CODE.
8. TYPICAL CLEANOUT SHALL BE CONFORM TO REQUIREMENTS OF LOCAL CODE.
9. TYPICAL CLEANOUT SHALL BE CONFORM TO REQUIREMENTS OF LOCAL CODE.
10. TYPICAL CLEANOUT SHALL BE CONFORM TO REQUIREMENTS OF LOCAL CODE.
11. TYPICAL CLEANOUT SHALL BE CONFORM TO REQUIREMENTS OF LOCAL CODE.
12. TYPICAL CLEANOUT SHALL BE CONFORM TO REQUIREMENTS OF LOCAL CODE.
13. TYPICAL CLEANOUT SHALL BE CONFORM TO REQUIREMENTS OF LOCAL CODE.
14. TYPICAL CLEANOUT SHALL BE CONFORM TO REQUIREMENTS OF LOCAL CODE.
15. TYPICAL CLEANOUT SHALL BE CONFORM TO REQUIREMENTS OF LOCAL CODE.
16. TYPICAL CLEANOUT SHALL BE CONFORM TO REQUIREMENTS OF LOCAL CODE.
17. TYPICAL CLEANOUT SHALL BE CONFORM TO REQUIREMENTS OF LOCAL CODE.
18. TYPICAL CLEANOUT SHALL BE CONFORM TO REQUIREMENTS OF LOCAL CODE.
19. TYPICAL CLEANOUT SHALL BE CONFORM TO REQUIREMENTS OF LOCAL CODE.
20. TYPICAL CLEANOUT SHALL BE CONFORM TO REQUIREMENTS OF LOCAL CODE.

EMC
 Engineers, Scientists, LLC
 1600 N. Westfield Blvd., Suite 200
 Cary, NC 27513
 919.487.1000
 Website: www.emceng.com

Greenville Park • Hendersonville • Midvale, GA
 Cary, NC • Raleigh, NC • Durham, NC • Chapel Hill, NC
 Research Triangle Park, NC • Winston-Salem, NC
 Greensboro, NC • Charlotte, NC

PORT OF BROOKINGS HARBOR
 BOAT YARD PAVING
 1630 LOWER HARBOR ROAD, BROOKINGS, OR 97415

DATE: 11 MAY 2021
 JOB NO. 4
 SHEET NO. 6
C6.1
 PROJECT DETAILS

NOTES

1. ALL PROJECT SECTIONS SHALL CONFORM TO REQUIREMENTS OF LOCAL CODE.
2. ALL PROJECT SECTIONS SHALL CONFORM TO REQUIREMENTS OF LOCAL CODE.
3. ALL PROJECT SECTIONS SHALL CONFORM TO REQUIREMENTS OF LOCAL CODE.
4. ALL PROJECT SECTIONS SHALL CONFORM TO REQUIREMENTS OF LOCAL CODE.
5. ALL PROJECT SECTIONS SHALL CONFORM TO REQUIREMENTS OF LOCAL CODE.
6. ALL PROJECT SECTIONS SHALL CONFORM TO REQUIREMENTS OF LOCAL CODE.
7. ALL PROJECT SECTIONS SHALL CONFORM TO REQUIREMENTS OF LOCAL CODE.
8. ALL PROJECT SECTIONS SHALL CONFORM TO REQUIREMENTS OF LOCAL CODE.
9. ALL PROJECT SECTIONS SHALL CONFORM TO REQUIREMENTS OF LOCAL CODE.
10. ALL PROJECT SECTIONS SHALL CONFORM TO REQUIREMENTS OF LOCAL CODE.
11. ALL PROJECT SECTIONS SHALL CONFORM TO REQUIREMENTS OF LOCAL CODE.
12. ALL PROJECT SECTIONS SHALL CONFORM TO REQUIREMENTS OF LOCAL CODE.
13. ALL PROJECT SECTIONS SHALL CONFORM TO REQUIREMENTS OF LOCAL CODE.
14. ALL PROJECT SECTIONS SHALL CONFORM TO REQUIREMENTS OF LOCAL CODE.
15. ALL PROJECT SECTIONS SHALL CONFORM TO REQUIREMENTS OF LOCAL CODE.
16. ALL PROJECT SECTIONS SHALL CONFORM TO REQUIREMENTS OF LOCAL CODE.
17. ALL PROJECT SECTIONS SHALL CONFORM TO REQUIREMENTS OF LOCAL CODE.
18. ALL PROJECT SECTIONS SHALL CONFORM TO REQUIREMENTS OF LOCAL CODE.
19. ALL PROJECT SECTIONS SHALL CONFORM TO REQUIREMENTS OF LOCAL CODE.
20. ALL PROJECT SECTIONS SHALL CONFORM TO REQUIREMENTS OF LOCAL CODE.



PORT OF BROOKINGS HARBOR

PORT OF BROOKINGS-HARBOR
2021 CIVIL IMPROVEMENTS

**SOUTH BASIN EMBANKMENT
RECONSTRUCTION**

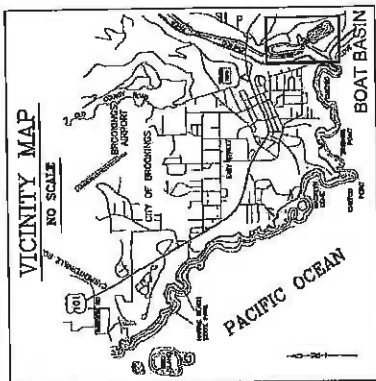

NATURAL FEATURES
EXISTING NATURAL RESOURCES OR NATURAL HAZARDS ON THE SUBJECT PROPERTY, INCLUDING WETLANDS, FLOOD PLAINS, FLOOD HAZARD AREAS, FLOOD PLAINS, OR FLOODWAYS TO BE DETERMINED BY AN ENGINEER.

EXISTING TREE CANOPY
THERE ARE NO EXISTING TREES ON THE SUBJECT PROPERTY.

CULTURAL RESOURCES
LOCALLY, OR FEDERALLY DESIGNATED HISTORIC AND/OR CULTURAL RESOURCES ON THE SITE, OR ON ADJACENT PARCELS TO BE DETERMINED BY AN ENGINEER.

PUBLIC SERVICES
PUBLIC UTILITY SERVICES, INCLUDING WATER, SEWER, STORM DRAINAGE, POWER, TELEPHONE, CABLE INTERNET, AND GAS ARE AVAILABLE TO THE SUBJECT PROPERTY.

UTILITY STATEMENT
EXISTING UNDERGROUND UTILITIES ILLUSTRATED IN THESE PLANS ARE APPROXIMATED BASED ON INFORMATION FROM CURRY COUNTY GIS ELEVATIONS ESTIMATES, OR HAVE BEEN LOCATED BY A UTILITY LOCATE COMPANY. LAYOUT INDICATED IS NOT TO BE RELIED ON AS BEING EXACT OR COMPLETE. ALL LINES WITHIN PROJECTED WORK ZONE SHALL BE FIELD VERIFIED AS REQUIRED PRIOR TO CONSTRUCTION.

PROJECT DESCRIPTION

TITLE: SOUTH BASIN EMBANKMENT RECONSTRUCTION
REFERENCE: PB113
LOCATION: SOUTH BASIN
TAX LOT(S): 401, 456, 1100, 1200, 1300, 1400

DRAWING REGISTER

Number	Description
PB113-C100	Cover sheet
PB113-C101	Notes
PB113-C102	Existing Condition
PB113-C102A	EXISTING EMBANKMENT VIEWS
PB113-C103	Embankment
PB113-C104	Details
PB113-C105	Plan details

PROJECT OVERVIEW
SCALE 1" = 200'

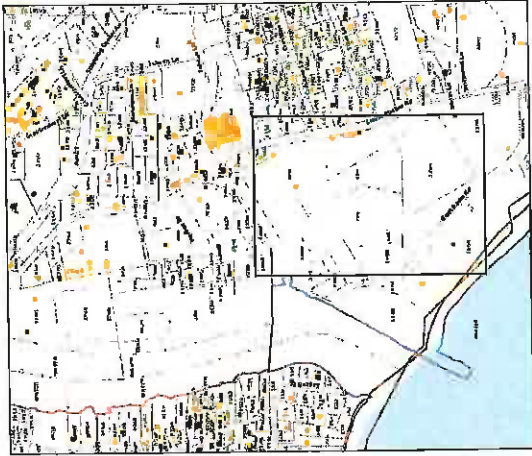
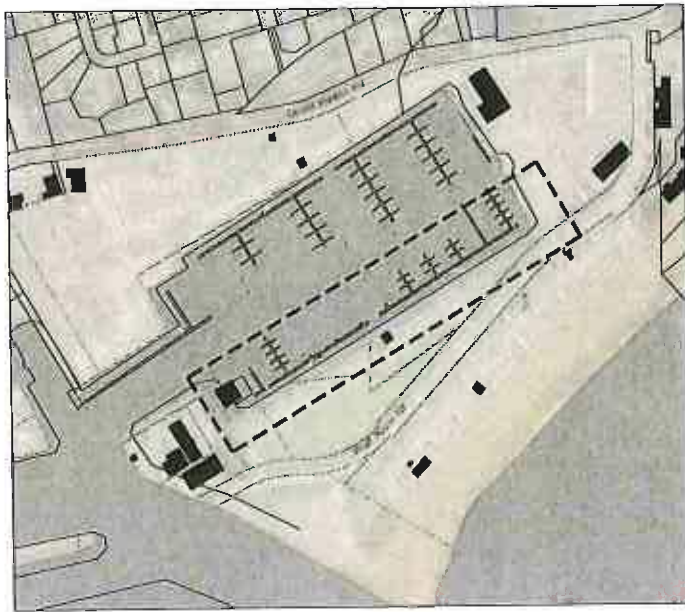

PORT OF BROOKINGS HARBOR
MAP OF TAX LOTS

PRELIM GRADING NOTES

1. DEO 1200-C PERMIT IS REQUIRED.
2. UNLESS DIRECTED OTHERWISE, REMOVE AND GRUBBED MATERIAL FROM THE SITE AND DISPOSE AT AN APPROVED LOCATION.
3. PRIOR TO THE START OF CONSTRUCTION, VERIFY GRADES AT SHARPS CORNERS AND MATCHING OR SECTION GRADE LOCATIONS.
4. EXPOSED SOILS SHALL BE PROTECTED DURING MET WEATHER. IF THE SITE SOILS ARE EXPOSED DURING MET WEATHER, THE USE OF CRUSHED ROCK PLACED AS ENGINEERED FILL IN THE BOTTOM OF THE EXCAVATIONS MAY BE NECESSARY TO PROTECT THE SUBGRADE. TAKE ALL PRECAUTIONS TO LIMIT SURFACE DISTURBANCE AND PROTECT THE SITE GRADING AREA FROM EROSION AND RUNOFF SAMPLING AND TESTING OTHERWISE NOTED IN THE CONTRACT SHALL BE AT THE EXPENSE OF THE CONTRACTOR. ALL TESTING OF MATERIALS AND WORKMANSHIP SHALL BE PERFORMED BY A CERTIFIED TESTER. RESULTS OF THE TESTS SHALL BE SENT DIRECTLY TO THE PROJECT ENGINEER AS WELL AS THE CONTRACTOR, BY THE LABORATORY. LOCATION AND FREQUENCY OF TESTS SHALL BE DESIGNATED BY THE GENERAL CONTRACTOR.
5. ALL CUT AND FILL SLOPES SHALL BE MAXIMUM OF 3:1.

LEGEND

—	ELEVATION
—	SUBGRADE MINOR CONTOUR
—	SUBGRADE MAJOR CONTOUR
—	PAVEMENT
—	GRAVELLITE
—	CONCRETE PAD
—	CONCRETE CURB
—	SLIT WALK
—	PAVED ROAD

PORT OF BROOKINGS
1530 Lower Harbor Rd, Brookings, OR 97415

DATE: 12/8/2020
DRAWN BY: [Name]
CHECKED BY: [Name]
SCALE: C-100
SHEET NO. 11

GENERAL NOTES
 These notes are intended for use in interpreting and implementing the tasks shown on the following construction plans and specifications sheets. These are in addition to the overall project specification and bid documents and contractual items.

These are intended for the use of the general contractor and his/her subcontractors in the demolition and reconstruction of the subject area of the Port of Brookings Harbor. Use for other purposes or at other sites is not recommended and is accomplished at the sole risk of the user.

These items are to be used as a supplement to the details provided on the plan sheets and specifications pages. Any discrepancies found among the drawings, the Specifications, referenced reports, these General Notes and other items listed on this sheet and the site conditions shall be reported to the Engineer, who shall correct such discrepancy in writing. Any work done by the General Contractor after discovery of such discrepancy shall be done at the General Contractor's risk. The General Contractor shall verify and coordinate dimensions among all drawings prior to proceeding with any work.

The embankment repair has been designed to resist anticipated vertical and lateral forces after the construction of all structural elements has been completed. Stability of the structure and slope areas prior to completion is the responsibility of the General Contractor. This responsibility includes, but is not limited to jobsite safety, construction means, methods, and sequences, temporary shoring, slope stability, formwork and bracing, use of equipment and construction procedures.

Construction observation by the Engineer is for checking for conformance with design aspects only and is not intended in any way to review and/or approve the General Contractor's construction procedures or relieve the contractor from providing a completed project, consistent with the plans and specifications and good construction practices. Special inspection by the engineer does not provide a certification of the project or relieve the contractor of all responsibility for a properly constructed project.

Standards Used for Design

All methods, materials and workmanship shall conform to the plans and specifications and ODOT Standard Specifications, unless elsewhere herein specified otherwise.
 International Building Code (IBC) 2009; 2010 Oregon Structure Specialty Code (OSSC); American Society of Civil Engineers (ASCE)

Other Notes

1. Jobsite safety is the responsibility of the Contractor.
2. All products and workmanship shall be new materials of good quality, acceptable for this type of construction. Work to be accomplished in a good and workmanlike manner.
3. All materials to be shipped, handled and stockpiled in accordance with the manufacturers recommendations and good construction practices.
4. Locations must be verified at the site with the geotechnical engineer and the Port of Brookings Harbor representative prior to placement.
5. Abide by local, state and federal building ordinances, including all safety requirements, in all phases of the project.
6. All phases of the project are to conform to the plans and specifications attached hereto and specifications provided by the owner and the engineer-of-record.
7. Proposed changes to project plans and specifications must be approved by the designer prior to acceptance and implementation at the site.
8. Proposed changes must be submitted in writing for review and approval/disapproval by the designer and the owner.
9. In no case shall changes, substitutions or omissions be made to the design or materials without the written authorization of the designer and the owner.
10. Authorization of a design change by the engineer does not constitute acceptance by the Port of Brookings Harbor, nor does it authorize additional funds for the changes. The Port's representative must authorize in writing the design change and applicable changes in the contract amount and/or construction time period prior to implementation of such changes.
11. Project schedule and general sequencing of all work must be reviewed and approved by the design engineer and the owner. Such approval does not relieve the contractor or his/her subcontractors of all responsibilities for proper execution of the subject project construction.
12. Sequencing of tasks that requires varying the installed sizes of project materials must be reviewed and approved by the design engineer and owner.
13. Traffic control and signage must be provided by the contractor unless otherwise stated in the contract. Access to the US Coast Guard facilities must be maintained during construction.
14. Contractor must understand that the project site is in a Harbor area subject to tidal fluctuations. Therefore, sequencing and project work must take into account effects of high and low tides.
15. Replacement of specified products by an "Equivalent" product must be approved by the design engineer and the owner. Redesign required for use of design engineer and the owner. Redesign required for use of alternate "Equivalent" materials is to be borne by the contractor.

1. DEC 1200-C PERMIT IS NOT REQUIRED.
2. UNLESS DIRECTED OTHERWISE, REMOVE CLEARED AND CRUMBED MATERIAL FROM THE SITE AND DISPOSE AT AN APPROVED LOCATION.
3. PRIOR TO THE START OF CONSTRUCTION, VERIFY GRADES AT SAWCUT LOCATIONS AND MATCHING OF EXISTING GRADE LOCATIONS.
4. MINIMIZE TRAFFIC ON SOIL AREAS DURING WET WEATHER. IF THE SITE SOILS ARE EXPOSED DURING WET WEATHER, THE USE OF CRUSHED ROCK PLACED AS ENGINEERED FILL IN THE BOTTOM OF THE EXCAVATIONS MAY BE NECESSARY TO PROTECT THE SUBGRADE. TAKE ALL PRECAUTIONS TO LIMIT SURFACE DISTURBANCE AND PROTECT THE SITE GRADING AREA FROM EROSION AND RUNOFF.
5. UNLESS OTHERWISE NOTED, THE SAMPLING AND TESTING OF MATERIALS FOR USE ON THE JOBSITE SHALL BE AT THE EXPENSE OF THE CONTRACTOR. ALL TESTING OF MATERIALS AND WORKMANSHIP SHALL BE PERFORMED BY A CERTIFIED TESTER. RESULTS OF THE TESTS SHALL BE SENT DIRECTLY TO THE PROJECT ENGINEER AS WELL AS THE CONTRACTOR, BY THE LABORATORY. LOCATION AND FREQUENCY OF TESTS SHALL BE DESIGNATED BY THE GENERAL CONTRACTOR.
6. ALL CUT AND FILL SLOPES SHALL BE MAXIMUM OF 2:1.

EROSION, SEDIMENTATION & POLLUTION CONTROL PLAN NOTES

1. PROJECT/PURPOSE - WITH THE PURPOSE OF MAINTAINING, REHABILITATING, REPLACING AND UPGRADING THE EXISTING WESTERN EMBANKMENT AT THE SOUTH BASIN OF PORT OF BROOKINGS, THE EXISTING EMBANKMENT WILL BE CLEARED DOWN TO SUITABLE SUBGRADE AT SLOPE BETWEEN 1.5:1 AND 2:1. A 4FT DEEP TRENCH WILL BE EXCAVATED AT THE BASE OF THE EMBANKMENT. A 3FT DEEP LAYER OF AGGREGATE WILL BE PLACED ON TOP OF THE SLOPE AND INTO THE TRENCH.
2. CONTRACTOR ACTIVITIES - CONTRACTOR ACTIVITIES ARE DESCRIBED AS EXCAVATION AND CLEARING USING A 25T EXCAVATOR. EXCAVATION AND SPREADING AT THE BASE OF THE SLOPE USING A LONG REACH EXCAVATOR. PLACEMENT OF GEOGRID, PLACEMENT OF CRUSHED AGGREGATE FROM FINE GRAVEL TO 2FT BOULDERS
3. SOIL DISTURBING ACTIVITIES - EXCAVATION WILL BE LIMITED TO EXISTING MARINA EDGES AS SHOWN ON DRAWING C102
4. NON-STORMWATER DISCHARGES - NO DEWATERING, WATER-LINE FLUSHING, PAVEMENT WASH WATERS OR IRRIGATION WATER DISCHARGES ARE PLANNED FOR THIS PROJECT.
5. ESTIMATED START DATE FOR CONSTRUCTION - 02/01/21 - 03/30/21
6. NEAREST SURFACE WATER BODIES - PORT OF BROOKINGS ICE HOUSE INLET IN THE COMMERCIAL BASIN (SOUTH BASIN) AND THE SPORT BASIN, NEAR DOCK 4 (NORTH BASIN).
7. RECEIVING WATERS - PACIFIC OCEAN
8. SPECIAL ENVIRONMENTAL CONSIDERATIONS - SEE SECTION BELOW DESCRIBING PRECAUTION REGARDING CRESTOSITE COATED PILES TO BE EXTRACTED. ESA OPINIONS PROVIDED BY USACE, WWS AND ODW.
9. DESIGNATED EPCC - THE DESIGNATED EROSION AND POLLUTION CONTROL MANAGER (EPCC) WHO WILL ASSURE COMPLIANCE WITH ALL ITEMS IN THIS PLAN IS TED FITZGERALD, PORT DIRECTOR, OR HIS DESIGNEE.

10. EROSION, SEDIMENTATION AND POLLUTION CONTROL BMPs - BEST MANAGEMENT PRACTICES (BMP) TO BE USED, WHEN APPLICABLE, TO PREVENT POLLUTION RELATED TO CONSTRUCTION ACTIVITIES LISTED IN THIS SECTION ARE AS FOLLOWS: A) OFFSITE VEHICLE TRACKING DUST PREVENTION - MEASURES WILL BE TAKEN TO PREVENT OFFSITE TRACKING OF MATERIALS, INCLUDING SWEETING PREVENTIONS. COVERING LOADS AND WETTING SOIL TO PREVENT DUST. B) ON SITE TUBES WILL BE DELIVERED, HANDLED, STORED, USED, AND APPLIED SO AS NOT TO BE RELEASED INTO THE WATERS OF THE STATE/US. FUELING WILL BE ACCOMPLISHED AWAY FROM THE WORK AREA. A SPILL CLEANUP KIT WILL BE AVAILABLE IF DEMAED BY THE EPCC TO BE REQUIRED. C) WASTE MANAGEMENT - HANDLING, STORAGE AND DISPOSAL OF SOLID WASTE AND/OR HAZARDOUS WASTE WILL BE DISPOSED INTO SUITABLE LANDFILL OFFSITE. D) INSPECTION AND MAINTENANCE - DAILY INSPECTION AND MAINTENANCE FOR ALL CONTROLS INCLUDED IN THE POLLUTION CONTROL PLAN AND THE EPCC WILL BE PERFORMED BY THE EPCC OR HIS DESIGNEE. E) EMPLOYEE AND SUBCONTRACTOR TRAINING - BEFORE ACTIVITIES BEGIN, ALL EMPLOYEES AND SUBCONTRACTORS WILL INCLUDE INFORMING PERSONNEL OF THE POSTED LOCATIONS OF THE POLLUTION CONTROL PLAN/EROSION AND SEDIMENT CONTROL PLAN/MSDS'S AND OF REVISED EMERGENCY PHONE NUMBERS. EMPLOYER WILL ALSO INCLUDE INFORMING PERSONNEL OF ACTIVATED MATERIAL MANAGEMENT PROCEDURES FOLLOWING A SPILL F) (CRITERIA 15) RECONSTRUCTION ASSOCIATED WITH ALL TEMPORARY OF THE ACTION AREA, FLAG THE BOUNDARIES OF CLEARING AND ENSURE THAT ALL TEMPORARY CONSTRUCTION TO MINIMIZE SOIL AND VEGETATION DISTURBANCE AND SITE PREPARATION - BORING SITE PREPARATION, CONSERVE NATIVE MATERIALS (GRAVEL, SAND, SILT, CLAY, AND OTHERS) DISPLACED BY CONSTRUCTION. WHENEVER PRACTICAL, LEAVE NATIVE MATERIALS (GRAVEL, SAND, SILT, CLAY, AND OTHERS) TO BE CLEARED. CLIP VEGETATION AT GROUNDLINE TO REMAIN ROOT MASS AND ENCOURAGE REESTABLISHMENT OF NATIVE VEGETATION. BUILDING AND RELATED STRUCTURES MAY NOT BE CONSTRUCTED INSIDE THE RIPARIAN HABITAT RESTORATION AREA (CRITERIA 17) HEAVY EQUIPMENT - HEAVY EQUIPMENT WILL BE SELECTED AND OPERATED AS NECESSARY TO MINIMIZE ADVERSE EFFECTS ON THE ENVIRONMENT AND ALL VEHICLES AND OTHER HEAVY EQUIPMENT WILL BE USED AS FOLLOWS: (A.) STORED, FUELED AND MAINTAINED IN A VEHICLE STAGING AREA PLACED 150 FEET OR MORE FROM ANY WATERBODY, OR IN AN ISOLATED HARD ZONE SUCH AS A PAVED PARKING LOT. (B.) INSPECTED DAILY FOR FUEL LEAKS BEFORE LEAVING THE VEHICLE STAGING AREA FOR OPERATION WITHIN 50 FEET OF ANY WATERBODY. (C.) STEAM-CLEANED BEFORE OPERATION BELOW ORDINARY HIGH WATER, AND AS OFTEN AS NECESSARY DURING OPERATION TO REMAIN FREE OF ALL EXTERNAL OIL, GREASE, MUD, SEEDS, ORGANISMS AND OTHER POTENTIALLY HARMFUL CONTAMINANTS. (D.) GENERATORS, GRADERS AND ANY OTHER STATIONARY EQUIPMENT OPERATED WITHIN 150 FEET OF ANY WATERBODY, WILL BE MAINTAINED AND PROTECTED AS NECESSARY TO PREVENT LEAKS AND SPILLS FROM ENTERING THE WATER 1) (CRITERIA 18)

- IN-WATER WORK PERIOD - ALL WORK WITHIN THE ACTIVE CHANNEL WILL BE COMPLETED IN ACCORDANCE WITH THE OREGON GUIDELINES FOR TIMING OF IN-WATER WORK TO PROTECT FISH AND WILDLIFE RESOURCES (ODFW 2000, OR THE MOST RECENT VERSION).
- J) (CRITERIA 21) EMBANKMENT INSTALLATION -
- K) (CRITERIA 24) SUBGRADE PREPARATION -



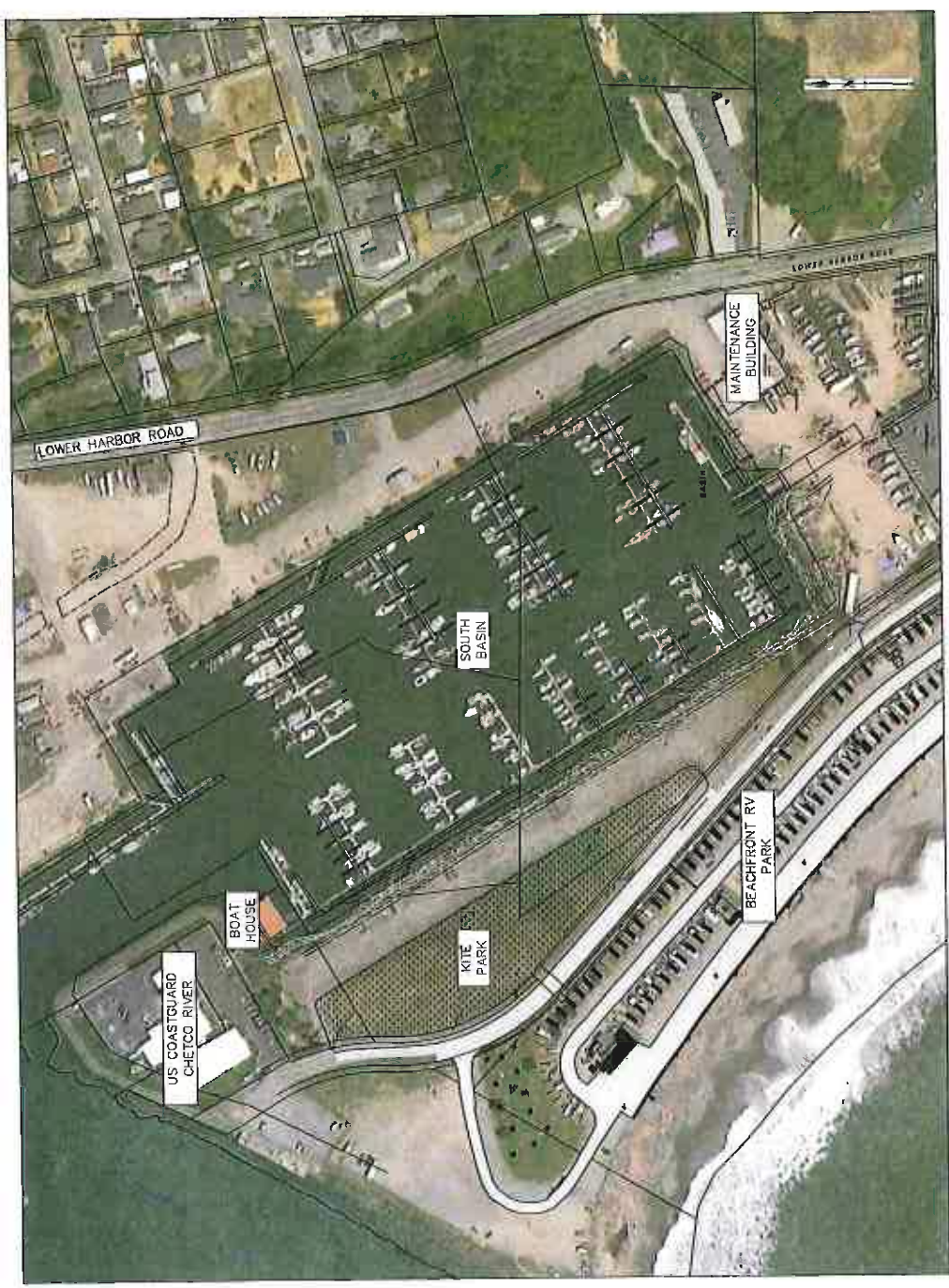
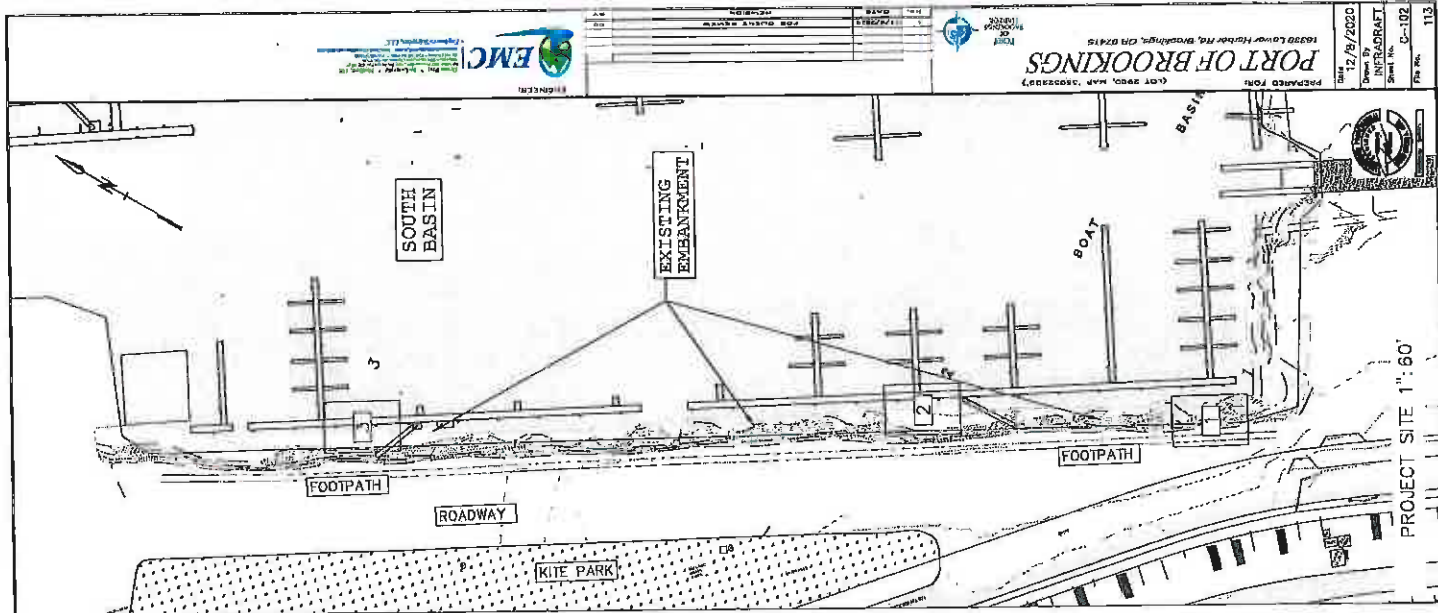

EXISTING CONDITIONS
 SCALE 1" = 100'



PREPARED FOR
PORT OF BROOKINGS
16300 Lower Harbor Rd, Brookings, OR 97518



NO.	DATE	DESCRIPTION
1	01/16/2021	PORT OF BROOKINGS
2	01/16/2021	PORT OF BROOKINGS
3	01/16/2021	PORT OF BROOKINGS
4	01/16/2021	PORT OF BROOKINGS
5	01/16/2021	PORT OF BROOKINGS
6	01/16/2021	PORT OF BROOKINGS
7	01/16/2021	PORT OF BROOKINGS
8	01/16/2021	PORT OF BROOKINGS
9	01/16/2021	PORT OF BROOKINGS
10	01/16/2021	PORT OF BROOKINGS



DATE: 01/16/2021
DRAWN BY: JINPAURAFI
CHECKED BY: C-102A
JOB NO.: 113

EMBANKMENT CONSTRUCTION
 Place fabric on the entire embankment. Place riprap similar to TYPICAL SECTION. Start with larger boulders (3' x 4' x 4') into the 5' cut made in the toe. Place another layer of rock atop that rock. Place a combination of smaller rocks, anywhere from 3' diameter to 1' diameter, above the toe, up to 12' above the bottom of the toe. The wall should be 5' thick at the bottom, up to 2' thick at the top.

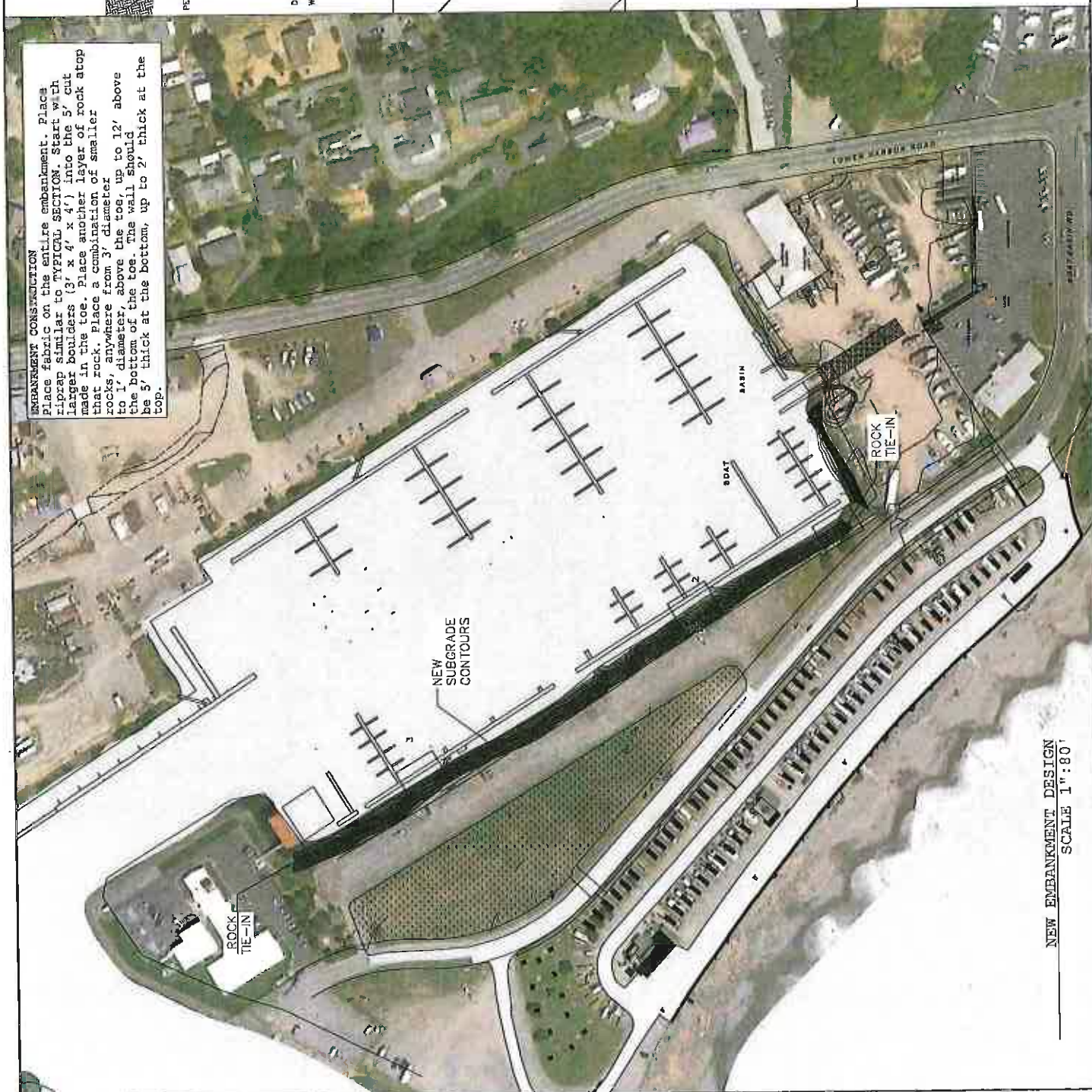

NEW EMBANKMENT DESIGN
 SCALE 1" = 80'

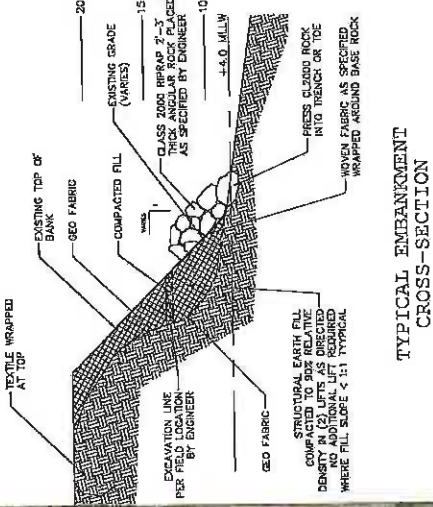

TYPICAL EMBANKMENT CROSS-SECTION

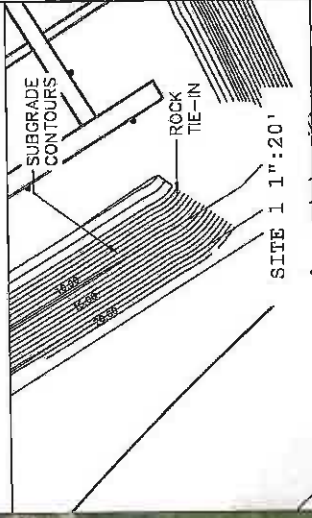

SITE 1 1" : 20'

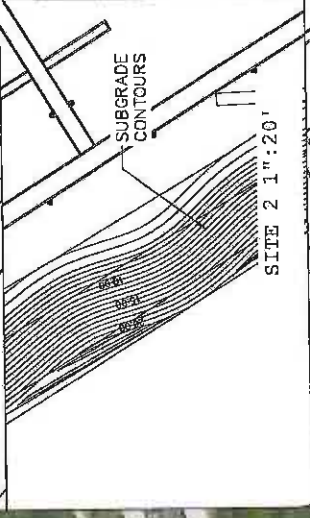

SITE 2 1" : 20'

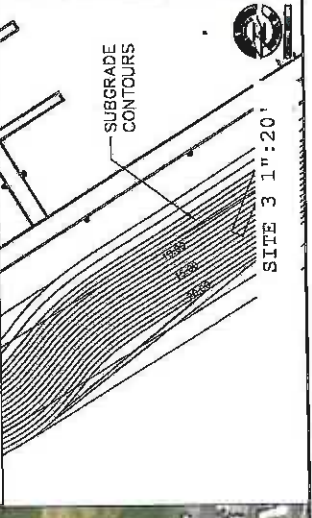

SITE 3 1" : 20'



Design Specifics of Rock & Construction
 The rock used (if 405 Mitigation is approved) for this project will be specified to follow test requirements found within AASHTO R 85 (Apparent specific gravity, percent absorption); ODOT TM 208A (degradation); and AASHTO R 104 (soundness). All rock specified in this project must be shaped to a third shape, and the thickness of any single rock shall not be greater than one-third of its length. Round rock will not be accepted. The class specified, be free rock must meet the gradation required for the class specified. Non-durable rock, shale or rock with shales, is not acceptable. Class 2000 rip rap is by definition a mixture of rocks that are 20% by weight of 1400 pounds to 2000 pounds and 80% by weight of 700 to 1400 pounds, 40% by weight 40 to 700 pounds and 0 to 10% to 40 pounds. Either a filter blanket of 16 inch layer of class 50, or specified filter fabric will be laid beneath the rock.

A clamshell, orange peel bucket, skip or similar approved device will be used which will transport the riprap material to its final destination. The riprap material will be placed on the riprap material. The riprap material and submaterial. However, rapidly varying, unstable, or undulating conditions occur occasionally, and excessive wave action, high winds and extreme flow turbulence can occur at this location. These conditions are among the reasons for the extent of protection required for this revetment includes design the vertical extent of protection for a distance greater than the length that is impacted. The height and foundation of toe depth. The design height of the rip rap (from surge) is to be equal to the design high water elevation (king tide plus storm surge) with adequate freeboard to accommodate wave action, super elevation from the channel bend, hydraulic jump, and flow irregularities, plus erratic phenomena such as unforeseen embankment settlement, accumulation of trash and debris from the river.

Scour depth is estimated at about 4 feet from the lowest elevation in the cross-section of the river at this point, utilizing the conservative assumption of median diameter of bed material to be about 0.15 m. Riprap thickness for Class 2000 is specified to be at least a 4 foot layer.

The filter beneath the riprap and overlying the structural fill is to prevent the migration of fine soil particles through structural voids and to distribute the weight of the armor units (riprap) to provide more uniform settlement, and also permits relief of hydrostatic pressures within the soils.

For the areas above the waterline at any given time the fabric or geotextile also prevents surface water from ponding beneath the rip rap. In addition to the consideration with respect to scour the flanks of this revetment are designed for upstream and downstream conditions.

General Construction, Erosion & Control Notes
 Final bank slopes will be between 1V:1.5H and 1V:2H. Bank preparation will consist of clearing debris and minor grading. Riprap placement will be by machine placing and hand placing. Hand placing will be performed as specified by EMC on steeper side slopes.

Re-handling or dragging to smooth revetment services tend to result in segregation and breakage of stone and are to be avoided. Stone will not be dropped from an excessive height.

Actions that will require the use of materials that are hazardous or toxic to human life (such as motor fuel, oil, or drilling fluid), are included within the pollution and erosion control plan sections of this narrative, to be managed by EMC and enforced by the Port of Brookings-Harbor. The plan includes practices to minimize erosion and sedimentation associated with all aspects of the project (e.g., staging areas, stockpiles, grading); to prevent debris from dropping or otherwise entering any stream or waterbody; and to prevent and control hazardous material spills.

Erosion controls will be monitored and maintained daily during the rainy season and weekly during the dry season as necessary to ensure controls are properly maintained. The following shows that the erosion controls are properly placed to prevent visible sediment discharge, the project will stop to evaluate erosion control measures. Repairs, replacements or the installation of additional erosion control measures will be completed before the project resumes.

If applicable, maintenance will include removal of sediment and debris from erosion controls like silt fences or hay bales once it has reached one-third of the exposed height of the control. Whenever practices that utilize materials to be left there they are found and in areas where cleared vegetation is to be clipped at ground level to remain root mass and encourage reestablishment of native vegetation.

Heavy equipment will be selected and operated as necessary to minimize adverse effects on the environment (e.g., minimally-sized, low pressure tires, minimal hard turn paths for tracked vehicles, temporary mats or plates within wet areas or sensitive soils); and all vehicles and other heavy equipment will be used as follows:

- 1) Stored, fueled and maintained in a vehicle staging area placed 150 feet or more from any waterbody, or in an isolated hard zone such as a paved parking lot, or lined surface;
- 2) Inspected regularly for fluid leaks before leaving the vehicle staging area or stream-cleared before operation below ordinary high water, and as often as necessary during operation to remain free of all external oil, grease, mud, seeds, dirt, and other visible contaminants and
- 3) Generators, cranes and any other stationary equipment operated within 150 feet of any waterbody will be maintained and protected as necessary to prevent leaks and spills from entering the water.

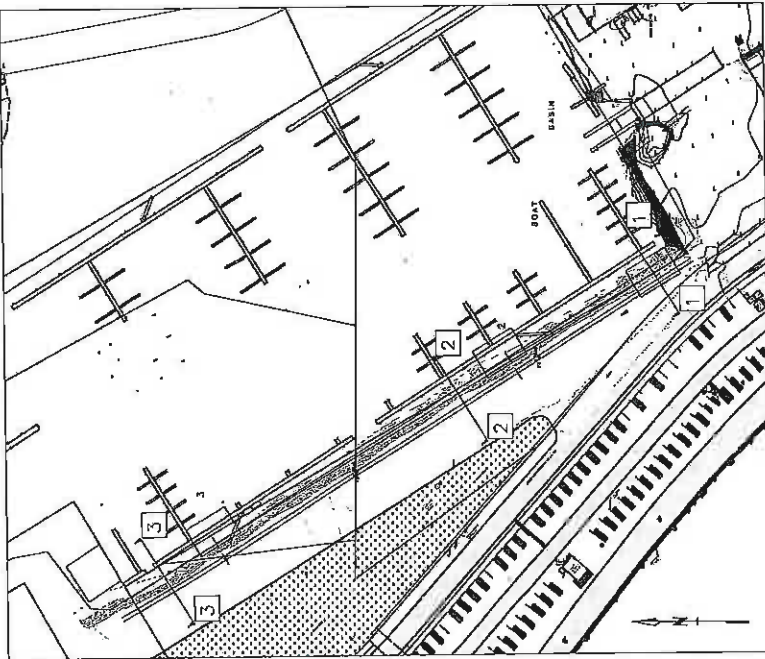

SITES 1, 2, 3 SECTION LINES

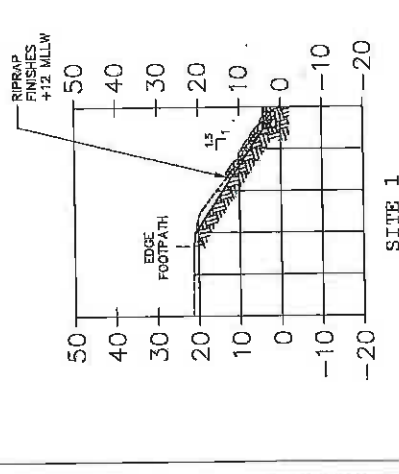
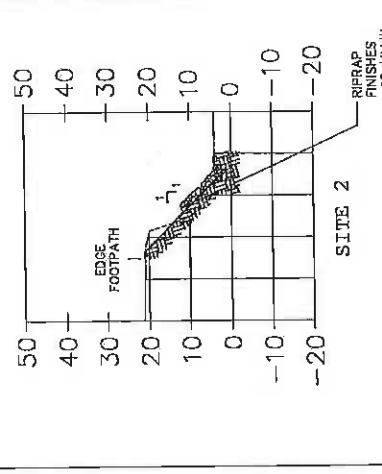
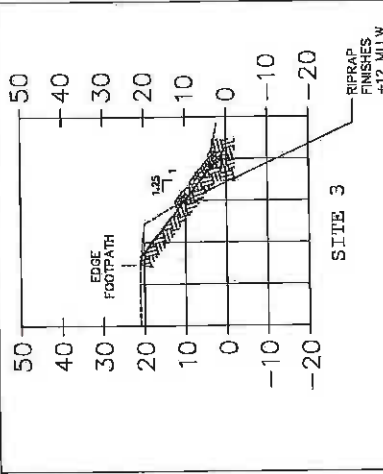

CROSS-SECTIONS NTS

Nonwoven Geotextile

ASTM F1061 - 07E 2001 100 US 300g/SM geotextile (unreinforced polypropylene) for use in erosion control applications. This geotextile meets or exceeds the following specifications: UV resistance, aging, abrasion, chemical resistance, and biological degradation. Meeting, ASTM D-4632, 200 lbs, 1.33S N, 304, 3.979 lbs/yd, 300 N, 3.962 N, 3.962 N, 511 N, 101 US (500) 1.000 mm, 1.000 mm, 1.000 mm, 1.000 mm, 75 g/m², 1.000 mm, 75%.

PROPERTY	TEST METHOD	ENGLISH	METRIC
Weight	ASTM D-4632	200 lbs	90.7 kg
Thickness	ASTM D-4632	3/8 in	9.5 mm
Stitching	ASTM D-4632	500 PPM	300 N
Strength	ASTM D-4632	180 lbs	81 N
UV Resistance	ASTM D-4632	118 hrs	511 N
Permeability	ASTM D-4632	1.000 mm	1.000 mm
Water Flow Rate	ASTM D-4632	75 g/m ²	75 g/m ²

VOLUME REPORT	
(APPROXIMATE)	
GEOTEXTILE FABRIC	4458 SQ YD
CLASS 2000 RIP RAP	2452.34 CU YD
ROLL SIZE ROLL DIAMETER AREA WEIGHT	1792 CU YD
	966 CU YD

ROLL SIZE ROLL DIAMETER AREA WEIGHT	
15' x 300'	250 lb
15' x 300'	250 lb
15' x 300'	250 lb

DATE	DESCRIPTION
12/27/2020	PREPARED FOR
12/27/2020	DATE
12/27/2020	BY
12/27/2020	CHECKED BY
12/27/2020	APPROVED BY

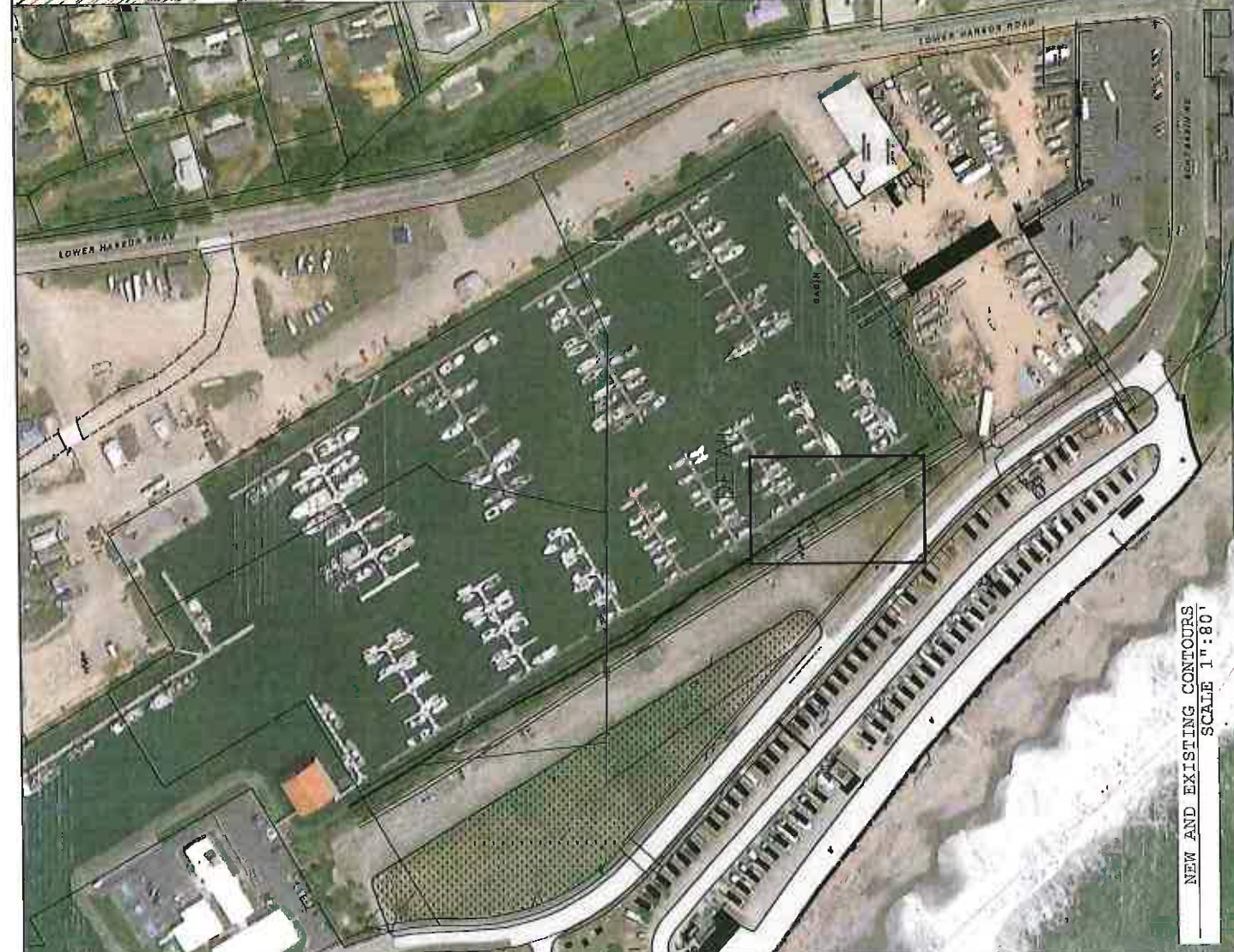
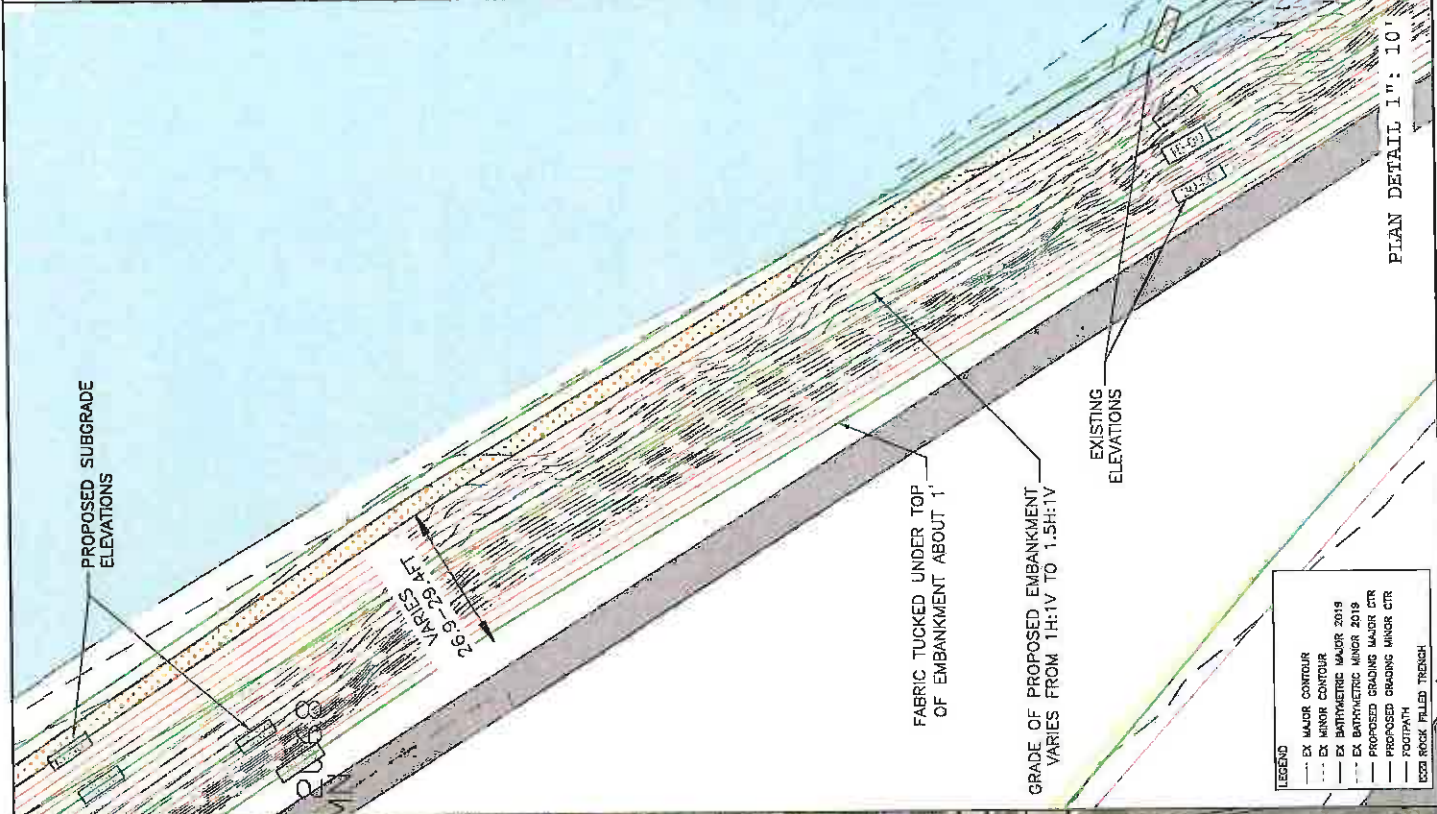

REV	BY	DATE

CHUCK PERRY & ASSOCIATES A PROFESSIONAL CORP
 1200 W. 4TH AVENUE, SUITE 1000
 PORTLAND, OREGON 97224
 PH: (503) 228-4646 FAX: (503) 228-4647
 www.chuckperry.com
 ENGINEERS ARCHITECTS PLANNERS
EMC Engineers/Architects, LLC



PORT OF BROOKINGS HARBOR
SOUTH BOAT BASIN WALL
 1630 LOWER HARBOR ROAD, BROOKINGS, OR 97415

DRAWN BY: JIG
 DATE: 11 APR 2011
 SHEET NO. 2
C0.0
 COVER SHEET

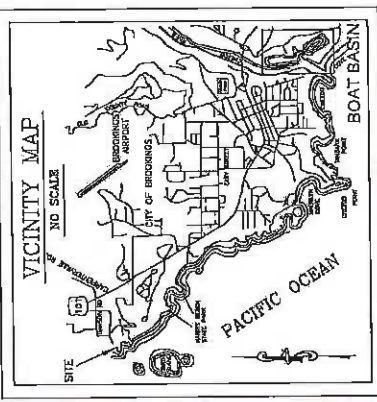

SHEET INDEX
 C0.0 COVER SHEET
 C1.0 EXISTING CONDITIONS
 C2.0 CONTON ROCK WALL

REVISIONS	BY	DATE

EMC
 Engineers/Scientists, LLC
 15000 SW 25th Avenue, Suite 100
 Portland, Oregon 97225
 Phone: 503.253.8800
 Fax: 503.253.8801
 Website: www.emc-engineers.com

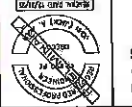

PORT OF BROOKINGS HARBOR
 SOUTH HARBOR ROAD, BROOKINGS, OR 97415
 SOUTH BOAT BASIN WALL

DRAWN BY: JG
 DATE: 16 APR 2021
 JOB NO.:
 SHEET NO.:
C1.0
 EXISTING
 CONDITIONS

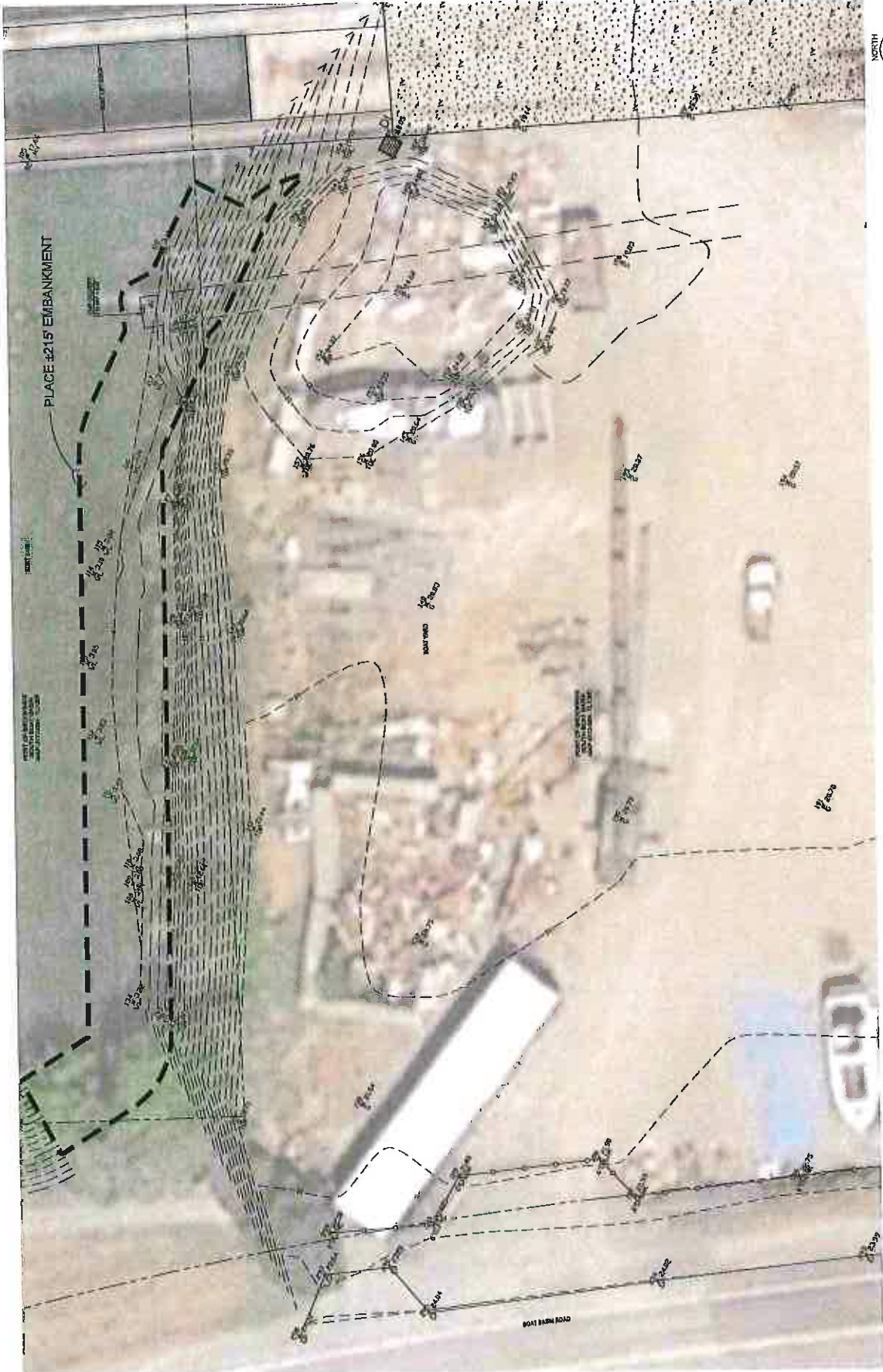

EXISTING CONDITIONS
 SCALE 1" = 20'



VERTICAL DATUM
 MEAN SEA LEVEL (MSL)
 ALL ELEVATIONS ARE TO MSL UNLESS OTHERWISE NOTED

HORIZONTAL DATUM
 NAD 83
 ALL HORIZONTAL COORDINATES ARE TO NAD 83 UNLESS OTHERWISE NOTED

SURVEY BY
 JAMES L. GUNTER, P.E.
 REGISTERED PROFESSIONAL ENGINEER
 LICENSE NO. 12345

NO.	DESCRIPTION	DATE	BY

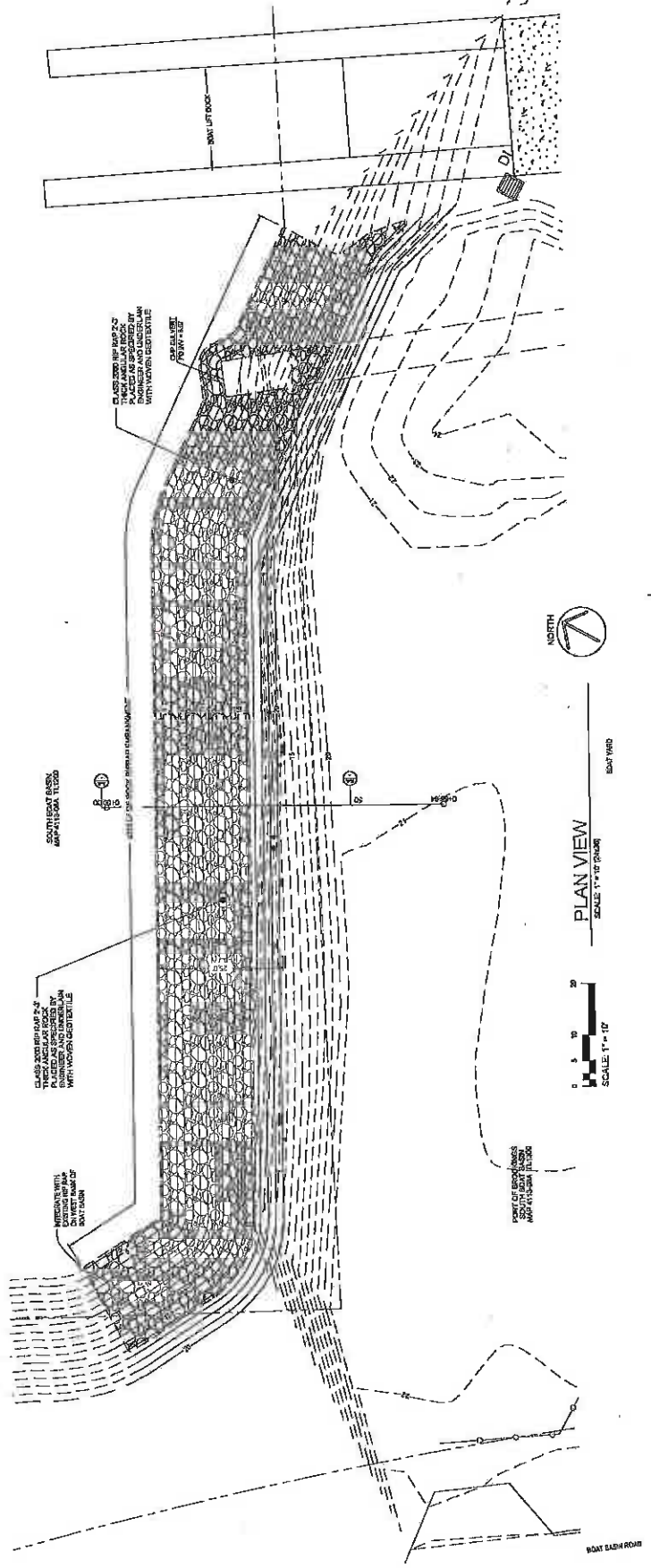

PLACE FABRIC ON THE ENTIRE EMBANKMENT. PLACE BERRAP
 SIMILAR TO TYPICAL SECTION. BERRAP WITH LAMINATED LAYER
 OF ROCK STOP THAT ROCKS. PLACE A COMBINATION OF SMALLER
 ROCKS AT THE BOTTOM OF THE TIE. THE WALL
 SHOULD BE 2 THICK AT THE BOTTOM, UP TO 2 THICK AT THE TOP.

EMBANKMENT CONSTRUCTION NOTES
PROPOSED ROCK EMBANKMENT - OPTION 4
 SCALE 1" = 10' 0" 0/08

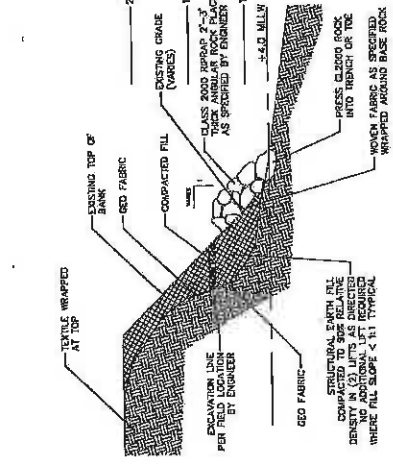

TYPICAL EMBANKMENT CROSS SECTION
 NOT TO SCALE

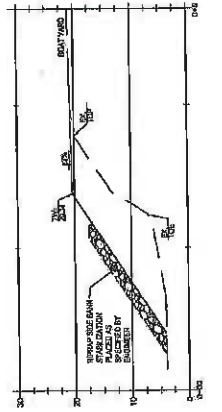

ROCK EMBANKMENT - SECTION A - A
 SCALE 1" = 10' 0" 0/08





PORT OF BROOKINGS-HARBOR
2021 CIVIL IMPROVEMENTS
PROPOSED ROAD

NATURAL FEATURES
EXISTING NATURAL RESOURCES OR NATURAL HAZARDS ON THE SUBJECT PROPERTY, INCLUDING WETLANDS, STREAMS, RIPARIAN AREAS, FLOOD PLAINS, OR FLOODWAYS TO BE DETERMINED BY ENGINEER

EXISTING TREE CANOPY
THERE ARE NO EXISTING TREES ON THE SUBJECT PROPERTY

CULTURAL RESOURCES
LOCALLY, OR FEDERALLY DESIGNATED HISTORIC AND/OR CULTURAL RESOURCES ON THE SITE OR ON ADJACENT PARCELS TO BE DETERMINED BY ENGINEER.

PUBLIC UTILITIES
PUBLIC UTILITY SERVICES, INCLUDING WATER, SEWER, STORM DRAINAGE, POWER, TELEPHONE, CABLE INTERNET, AND GAS ARE AVAILABLE TO THE SUBJECT PROPERTY.

UTILITY STATEMENT
EXISTING UNDERGROUND UTILITIES ILLUSTRATED IN THESE PLANS ARE APPROXIMATED BASED ON MAPS OBTAINED FROM CURRY COUNTY GIS ELEVATIONS ESTIMATES, OR HAVE BEEN LOCATED BY A UTILITY LOCATE COMPANY. LAYOUT INDICATED IS NOT TO BE RELIED ON AS BEING EXACT OR COMPLETE. ALL LINES WITHIN PROJECTED WORK ZONE SHALL BE FIELD VERIFIED AS REQUIRED PRIOR TO CONSTRUCTION.

PROJECT DESCRIPTION
TITLE: PROPOSED ROAD
REFERENCE: 140
LOCATION: HARBOR ST
TAX LOT(S): 2500,2600,2700,2800
2900,2999,402

DRAWING REGISTER
140-CV COVER SHEET
140-C100 NOTES
140-C101 EXISTING CONDITIONS
140-C102 PROPOSED GRADING
140-C103 PROPOSED PAVING
140-C104 PROPOSED DRAINAGE
140-C105 DETAILS
140-C106 DETAILS



PROJECT OVERVIEW
SCALE 1"=200'

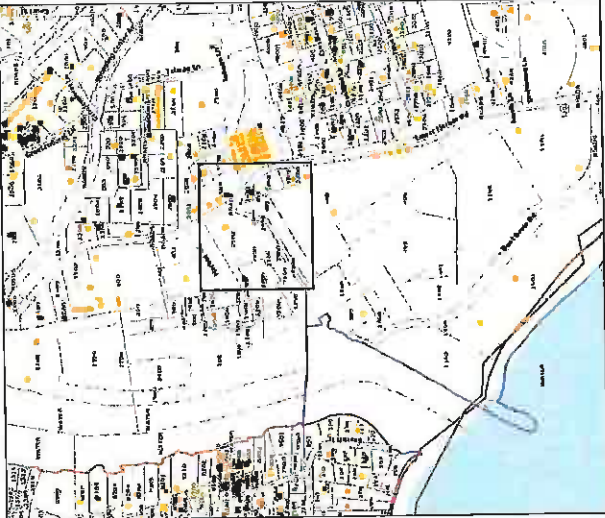

PORT OF BROOKINGS HARBOR
MAP OF TAX LOTS

- PRELIM GRADING NOTES**
1. DEQ 1200-C PERMIT IS REQUIRED.
 2. UNLESS DIRECTED OTHERWISE, REMOVE CLEARED AND GROBBED MATERIAL FROM THE SITE AND DISPOSE AT AN APPROVED LOCATION, PRIOR TO THE START OF CONSTRUCTION.
 3. VERIFY GRADES AT SAWCUT LOCATIONS AND MATCHING OF EXISTING GRADE LOCATIONS.
 4. MINIMIZE TRAFFIC ON SOIL AREAS DURING WET WEATHER. IF THE SITE SOILS ARE EXPOSED DURING WET WEATHER, THE USE OF CRUSHED ROCK PLACED AS ENGINEERED FILL IN THE BOTTOM OF THE EXCAVATIONS MAY BE NECESSARY TO PROTECT THE SUBGRADE. TAKE ALL PRECAUTIONS TO LIMIT SURFACE DISTURBANCE AND PROTECT THE SITE GRADING AREA FROM EROSION AND RUNOFF.
 5. UNLESS OTHERWISE NOTED, THE SAMPLING AND TESTING OF MATERIALS FOR USE ON THE JOBSITE SHALL BE AT THE EXPENSE OF THE CONTRACTOR. ALL TESTING OF MATERIALS AND WORKMANSHIP SHALL BE PERFORMED BY A CERTIFIED TESTER. RESULTS OF THE TESTS SHALL BE SENT DIRECTLY TO THE PROJECT ENGINEER AS WELL AS THE CONTRACTOR, BY THE LABORATORY. LOCATION AND FREQUENCY OF TESTS SHALL BE DESIGNATED BY THE GENERAL CONTRACTOR.
 6. ALL CUT AND FILL SLOPES SHALL BE MAXIMUM OF 2:1.

LEGEND

5	ELEVATION
---	SUBGRADE MINOR CONTOUR
---	SUBGRADE MAJOR CONTOUR
---	PARCEL
---	GEOTEXTILE
---	CONCRETE PAD
---	EXISTING GRASS
---	SLIP RAY
---	PAVED ROAD



EMC ENGINEERS
16390 Lower Harbor Rd, Brookings, OR 97415
PREPARED FOR: (Lot 2800, MAP 5802202B)
DATE: 04/04/2021
DRAWN BY: INFRADRAFT
SHEET NO.: CV
FILE NO.: 140

GRADING NOTES

1. PRIOR TO THE CONSTRUCTION OF EMBANKMENTS, THE CONTRACTOR SHALL EXCAVATE UNSUITABLE FOUNDATION MATERIAL, BASEMENTS, TRENCHES AND HOLES ENCOUNTERED WITHIN EMBANKMENT LIMITS SHALL BE FILLED WITH APPROVED MATERIAL. PRIOR TO BACKFILLING THE CONTRACTOR SHALL BREAK CONCRETE FLOORS OF BASEMENTS AS DIRECTED. THE CONTRACTOR SHALL BREAK UP AND ROUGHEN THE GROUND SURFACE BEFORE EMBANKMENT'S MATERIAL IS PLACED THE NATURAL GROUND UNDERLYING EMBANKMENT'S SHELL BE COMPACTED TO THE DENSITY SPECIFIED FOR THE EMBANKMENT MATERIALS TO BE PLACED, AND TO THE DEPTH OF THE GRUBBING OR A MINIMUM OF 6 INCHES.
2. EMBANKMENT CONSTRUCTION SHALL INCLUDE PREPARATION OF THE AREAS UPON WHICH EMBANKMENTS ARE PLACED, THE PLACEMENT AND COMPACTION OF APPROVED EMBANKMENT MATERIALS AND FILLING OF HOLES, PITS AND OTHER DEPRESSIONS WITHIN THE SUBDIVISION. THE CONTRACTOR SHALL PLACE EMBANKMENTS AND FILLS IN THE HORIZONTAL LAYERS OF 8 INCHES MAXIMUM DEPTH AND COMPACT EACH LAYER TO THE DENSITY SPECIFIED.
4. EMBANKMENT SHALL NOT BE CONSTRUCTED WHEN THE EMBANKMENT MATERIAL OR THE FOUNDATION ON WHICH THE EMBANKMENT WOULD BE PLACED IS FROZEN.
5. IMMEDIATELY PRIOR TO COMPLETION OF THE EARTHWORK, THE CONTRACTOR SHALL CLEAN THE ENTIRE WORK AREA OF DEBRIS AND FOREIGN MATTER.
6. THE MAXIMUM DENSITY OF COMPACTED MATERIAL WILL BE DETERMINED BY AASHTO T-99
7. THE CONTRACTOR SHALL COMPACT ALL EMBANKMENTS, FILLS AND BACKFILLS TO A MINIMUM IN PLACE DENSITY OF 95 PERCENT.
8. THE CONTRACTOR SHALL WATER THE MATERIALS TO PROVIDE OPTIMUM MOISTURE FOR COMPACTION OF EMBANKMENT AND BACKFILLS. EMBANKMENTS OR BACKFILL MATERIALS SHALL NOT BE PLACED IN FINAL POSITION UNTIL MOISTURE IN EXCESS OF OPTIMUM MOISTURE HAS BEEN REMOVED.
9. IF THE SPECIFIED COMPACTION IS NOT OBTAINED, THE CONTRACTOR SHALL NOTIFY THE ENGINEER. THE CONTRACTOR MAY BE REQUIRED TO USE A MODIFIED COMPACTION PROCEDURE OR APPLY ADDITIONAL COMPACTIVE EFFORT. IF APPROVED MATERIALS MEETING THE SPECIFICATIONS CANNOT BE COMPACTED TO THE REQUIRED DENSITY REGARDLESS OF COMPACTIVE EFFORT OR METHOD, THE ENGINEER MAY REDUCE THE REQUIRED DENSITY OR DIRECT THE ALTERNATE MATERIALS BE USED. IN NO CASE SHALL EARTHWORK OPERATIONS PROCEED UNTIL THE CONTRACTOR IS ABLE TO COMPACT THE MATERIAL TO THE SATISFACTION OF THE ENGINEER.
10. DEC 1200-C PERMIT IS NOT REQUIRED.
11. UNLESS DIRECTED OTHERWISE, REMOVE CLEARED AND GRUBBED MATERIAL FROM THE SITE AND DISPOSE AT AN APPROVED LOCATION.
12. UNLESS OTHERWISE NOTED, THE SAMPLING AND TESTING OF MATERIALS FOR USE ON THE JOBSITE SHALL BE AT THE EXPENSE OF THE CONTRACTOR. ALL TESTING OF MATERIALS AND WORKMANSHIP SHALL BE PERFORMED BY A CERTIFIED TESTER. RESULTS OF THE TESTS SHALL BE SENT DIRECTLY TO THE PROJECT ENGINEER AS WELL AS THE CONTRACTOR, BY THE LABORATORY. LOCATION AND FREQUENCY OF TESTS SHALL BE DESIGNATED BY THE GENERAL CONTRACTOR.
13. ALL CUT AND FILL SLOPES SHALL BE MAXIMUM OF 2:1.

GEOTECHNICAL NOTE

THE CONTRACTOR SHALL COORDINATE CONSTRUCTION ACTIVITIES WITH THE PROJECT ENGINEER FOR REQUIRED REMEDIATION. THE CONTRACTOR SHALL COORDINATE WITH THE PROJECT ENGINEER FOR REQUIRED SITE OBSERVATIONS AND TESTING OF ALL FILLS.

GENERAL NOTES

NO SCALE

319



NO.	DATE	REVISION	BY

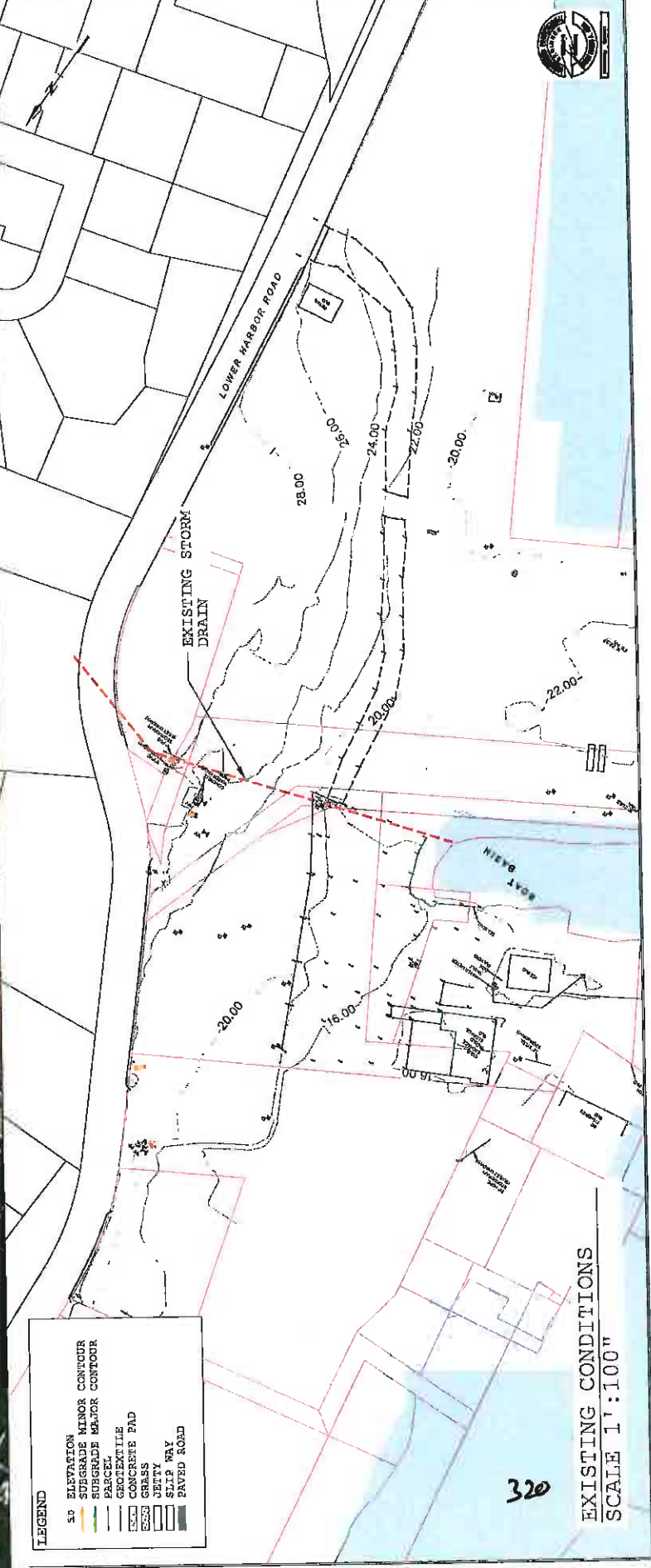

LEGEND

	5.0 ELEVATION
	SUBGRADE MINOR CONTOUR
	SUBGRADE MAJOR CONTOUR
	PARCEL
	GEOTECHNICAL
	CONCRETE PAD
	EDGE GRASS
	JETTY WAY
	SLIP WAY
	PAVED ROAD

320

EXISTING CONDITIONS
 SCALE 1"=100"



NO.	DATE	REVISION



NO.	DATE	REVISION

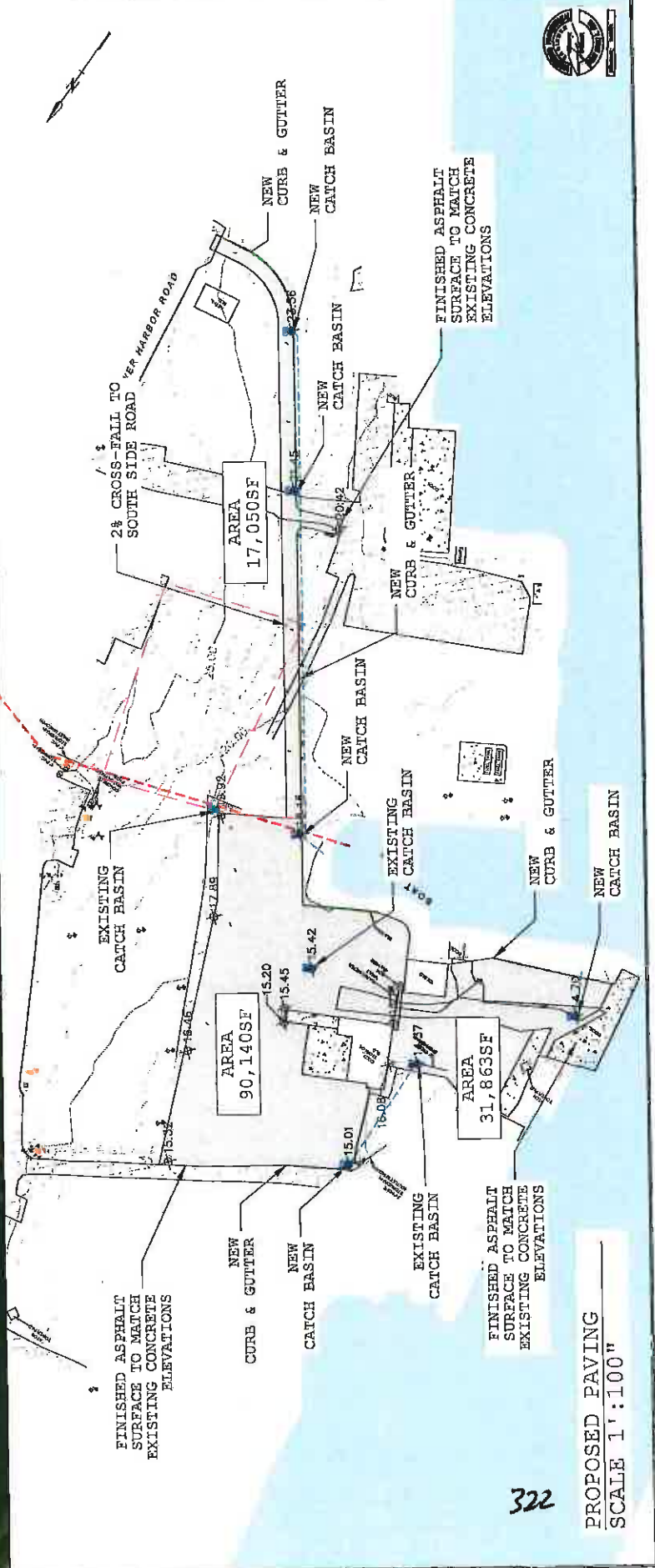

PROPOSED PAVING
 SCALE 1" = 100"

322

NO.	DATE	REVISION



323

STORMWATER ATTENUATION
 SCALE 1" = 100'

--	--	--	--	--	--	--	--	--	--

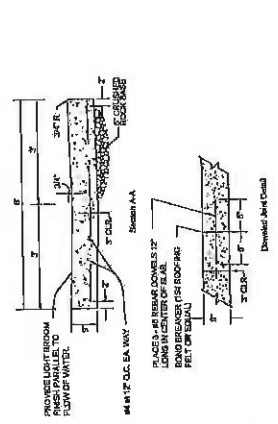
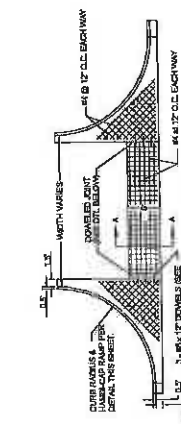

- NOTES**
1. CONCRETE TO BE CONCRETE ON GRADE (CONCRETE ENERGY AND FLOOR DETAIL ON PAVEMENT EXCLUDED)
 2. SUBGRADE AND BACKFILL SHALL BE COMPACTED TO 95% RELATIVE DENSITY.
 3. TRENCH BACKFILL SHALL BE WASTE TRENCH TO ASSURE TIGHT.

327 DRIVEWAY APRON WITH VALLEY GUTTER
 SCALE: NTS

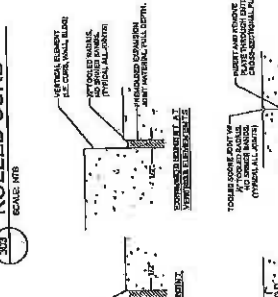
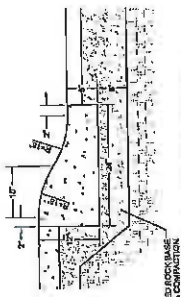

- NOTES**
1. CONCRETE TO BE CONCRETE ON GRADE (CONCRETE ENERGY AND FLOOR DETAIL ON PAVEMENT EXCLUDED)
 2. SUBGRADE AND BACKFILL SHALL BE COMPACTED TO 95% RELATIVE DENSITY.
 3. TRENCH BACKFILL SHALL BE WASTE TRENCH TO ASSURE TIGHT.

328 ROLLED CURB
 SCALE: NTS

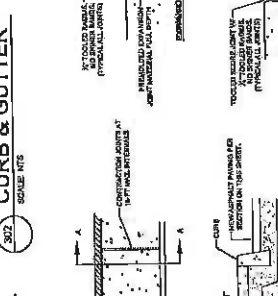
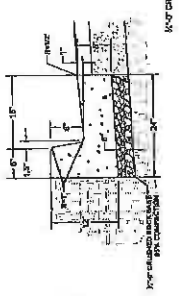

- NOTES**
1. CONCRETE TO BE CONCRETE ON GRADE (CONCRETE ENERGY AND FLOOR DETAIL ON PAVEMENT EXCLUDED)
 2. SUBGRADE AND BACKFILL SHALL BE COMPACTED TO 95% RELATIVE DENSITY.
 3. TRENCH BACKFILL SHALL BE WASTE TRENCH TO ASSURE TIGHT.

329 CURB & GUTTER
 SCALE: NTS

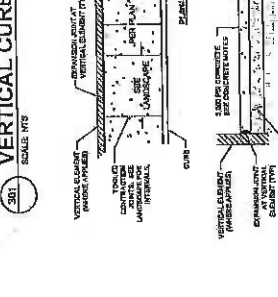
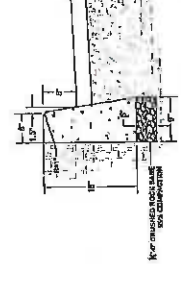

- NOTES**
1. CONCRETE TO BE CONCRETE ON GRADE (CONCRETE ENERGY AND FLOOR DETAIL ON PAVEMENT EXCLUDED)
 2. SUBGRADE AND BACKFILL SHALL BE COMPACTED TO 95% RELATIVE DENSITY.
 3. TRENCH BACKFILL SHALL BE WASTE TRENCH TO ASSURE TIGHT.

330 VERTICAL CURB
 SCALE: NTS

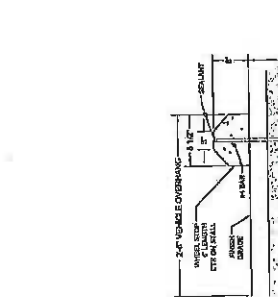

- NOTES**
1. CONCRETE TO BE CONCRETE ON GRADE (CONCRETE ENERGY AND FLOOR DETAIL ON PAVEMENT EXCLUDED)
 2. SUBGRADE AND BACKFILL SHALL BE COMPACTED TO 95% RELATIVE DENSITY.
 3. TRENCH BACKFILL SHALL BE WASTE TRENCH TO ASSURE TIGHT.

331 VERTICAL CURB
 SCALE: NTS



- NOTES**
1. CONCRETE TO BE CONCRETE ON GRADE (CONCRETE ENERGY AND FLOOR DETAIL ON PAVEMENT EXCLUDED)
 2. SUBGRADE AND BACKFILL SHALL BE COMPACTED TO 95% RELATIVE DENSITY.
 3. TRENCH BACKFILL SHALL BE WASTE TRENCH TO ASSURE TIGHT.

332 WHEEL STOP
 SCALE: NTS

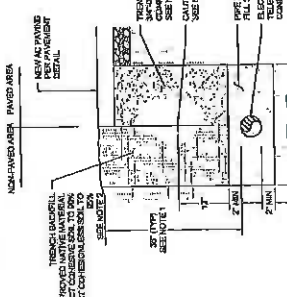
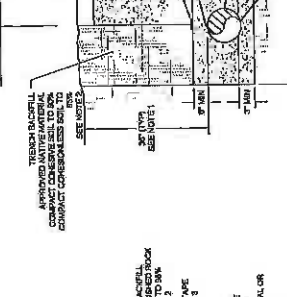
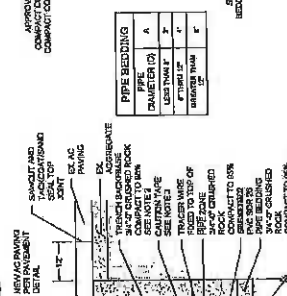
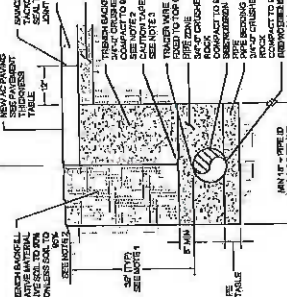
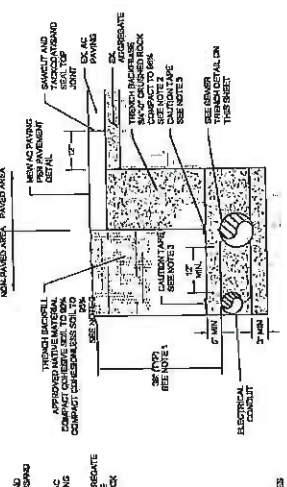
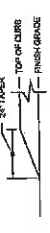

- NOTES**
1. CONCRETE TO BE CONCRETE ON GRADE (CONCRETE ENERGY AND FLOOR DETAIL ON PAVEMENT EXCLUDED)
 2. SUBGRADE AND BACKFILL SHALL BE COMPACTED TO 95% RELATIVE DENSITY.
 3. TRENCH BACKFILL SHALL BE WASTE TRENCH TO ASSURE TIGHT.

- NOTES**
1. CONCRETE TO BE CONCRETE ON GRADE (CONCRETE ENERGY AND FLOOR DETAIL ON PAVEMENT EXCLUDED)
 2. SUBGRADE AND BACKFILL SHALL BE COMPACTED TO 95% RELATIVE DENSITY.
 3. TRENCH BACKFILL SHALL BE WASTE TRENCH TO ASSURE TIGHT.

- NOTES**
1. CONCRETE TO BE CONCRETE ON GRADE (CONCRETE ENERGY AND FLOOR DETAIL ON PAVEMENT EXCLUDED)
 2. SUBGRADE AND BACKFILL SHALL BE COMPACTED TO 95% RELATIVE DENSITY.
 3. TRENCH BACKFILL SHALL BE WASTE TRENCH TO ASSURE TIGHT.

- NOTES**
1. CONCRETE TO BE CONCRETE ON GRADE (CONCRETE ENERGY AND FLOOR DETAIL ON PAVEMENT EXCLUDED)
 2. SUBGRADE AND BACKFILL SHALL BE COMPACTED TO 95% RELATIVE DENSITY.
 3. TRENCH BACKFILL SHALL BE WASTE TRENCH TO ASSURE TIGHT.

- NOTES**
1. CONCRETE TO BE CONCRETE ON GRADE (CONCRETE ENERGY AND FLOOR DETAIL ON PAVEMENT EXCLUDED)
 2. SUBGRADE AND BACKFILL SHALL BE COMPACTED TO 95% RELATIVE DENSITY.
 3. TRENCH BACKFILL SHALL BE WASTE TRENCH TO ASSURE TIGHT.

324 JOINT TRENCH DETAIL
 SCALE: NTS

325 WATER TRENCH DETAIL
 SCALE: NTS

326 SEWER TRENCH DETAIL
 SCALE: NTS

327 CONDUIT TRENCH DETAIL
 SCALE: NTS

EMC
 Earth's Most Critical Technology
 Engineering Technology, LLC
 3555 S. 16th Street, Suite 100
 Phoenix, AZ 85048
 Phone: 602-998-0000
 Fax: 602-998-0001
 www.emctech.com

JASON A. SMITH
 Professional Engineer
 No. 00000000000000000000
 State of Arizona
 License No. 00000000000000000000
 Issue Date 01/01/2010

HAINP DRAINAGE
 2020 IMPROVEMENTS
 PORT OF TEBBOK-KING'S HARBOR
 10300 W. TEBBOK BLVD, PHOENIX, AZ 85042

DATE: 09/01/20	JOB NO: 20-XXX	C106
SCALE: NTS	SCALE: NTS	SCALE: NTS

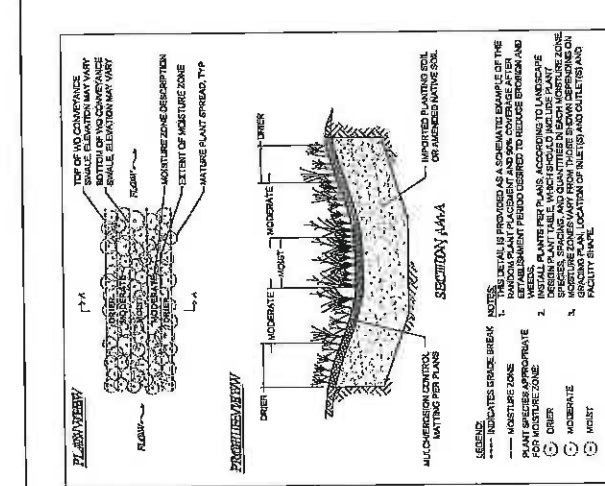
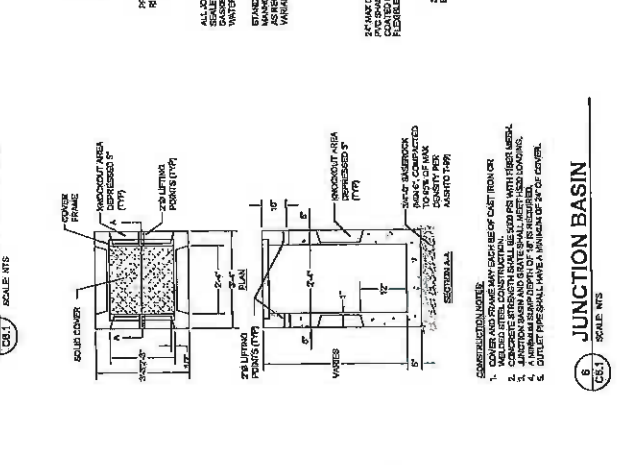
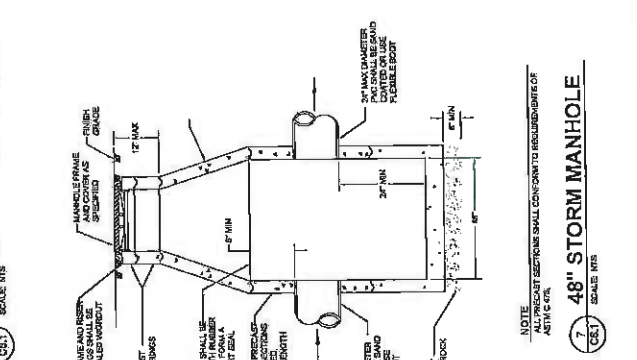
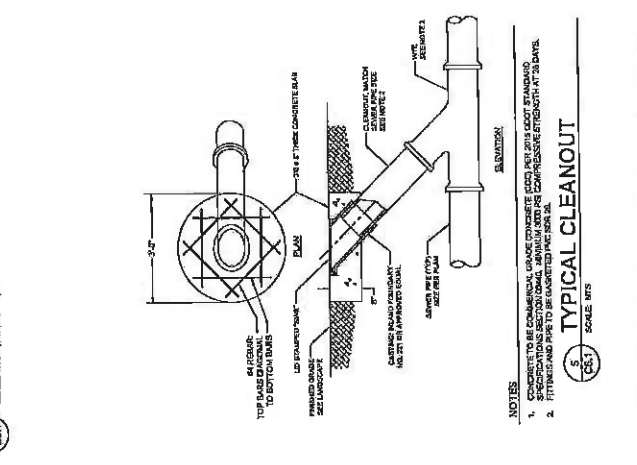
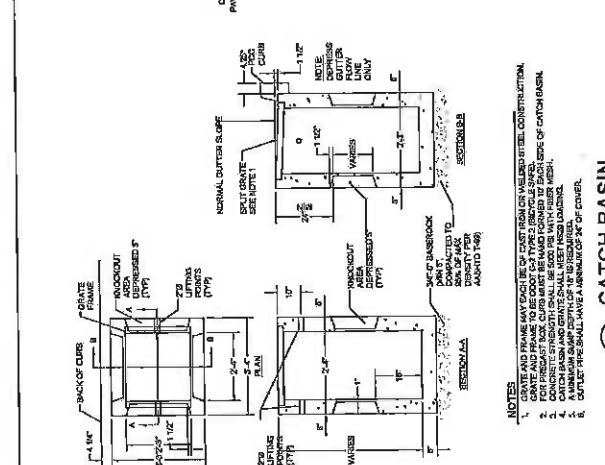
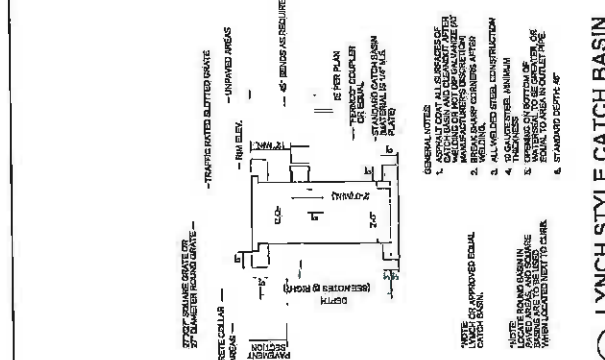
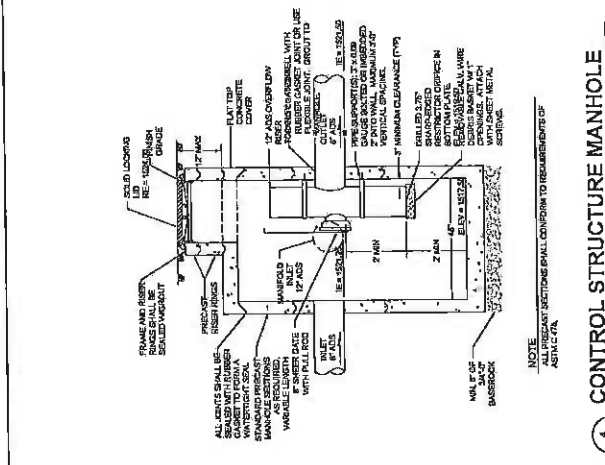

Reggie Valley Water Quality Conveyance Swails Planting Schematic
 BMP 6.03
 Scale: NTS

General Notes for Vegetated BMPs:
 1. This BMP is designed to provide a vegetated area that will filter and absorb runoff from the watershed. The vegetated area should be established and maintained to ensure the BMP is effective.
 2. The vegetated area should be established and maintained to ensure the BMP is effective.
 3. The vegetated area should be established and maintained to ensure the BMP is effective.
 4. The vegetated area should be established and maintained to ensure the BMP is effective.
 5. The vegetated area should be established and maintained to ensure the BMP is effective.
 6. The vegetated area should be established and maintained to ensure the BMP is effective.
 7. The vegetated area should be established and maintained to ensure the BMP is effective.
 8. The vegetated area should be established and maintained to ensure the BMP is effective.
 9. The vegetated area should be established and maintained to ensure the BMP is effective.
 10. The vegetated area should be established and maintained to ensure the BMP is effective.
 11. The vegetated area should be established and maintained to ensure the BMP is effective.
 12. The vegetated area should be established and maintained to ensure the BMP is effective.
 13. The vegetated area should be established and maintained to ensure the BMP is effective.
 14. The vegetated area should be established and maintained to ensure the BMP is effective.
 15. The vegetated area should be established and maintained to ensure the BMP is effective.
 16. The vegetated area should be established and maintained to ensure the BMP is effective.
 17. The vegetated area should be established and maintained to ensure the BMP is effective.
 18. The vegetated area should be established and maintained to ensure the BMP is effective.
 19. The vegetated area should be established and maintained to ensure the BMP is effective.
 20. The vegetated area should be established and maintained to ensure the BMP is effective.

Storm Water Design Manual
 Water Quality Conveyance Swails
 Planting Schematic
 BMP 6.03
 Scale: NTS

General Notes for Vegetated BMPs:
 1. This BMP is designed to provide a vegetated area that will filter and absorb runoff from the watershed. The vegetated area should be established and maintained to ensure the BMP is effective.
 2. The vegetated area should be established and maintained to ensure the BMP is effective.
 3. The vegetated area should be established and maintained to ensure the BMP is effective.
 4. The vegetated area should be established and maintained to ensure the BMP is effective.
 5. The vegetated area should be established and maintained to ensure the BMP is effective.
 6. The vegetated area should be established and maintained to ensure the BMP is effective.
 7. The vegetated area should be established and maintained to ensure the BMP is effective.
 8. The vegetated area should be established and maintained to ensure the BMP is effective.
 9. The vegetated area should be established and maintained to ensure the BMP is effective.
 10. The vegetated area should be established and maintained to ensure the BMP is effective.
 11. The vegetated area should be established and maintained to ensure the BMP is effective.
 12. The vegetated area should be established and maintained to ensure the BMP is effective.
 13. The vegetated area should be established and maintained to ensure the BMP is effective.
 14. The vegetated area should be established and maintained to ensure the BMP is effective.
 15. The vegetated area should be established and maintained to ensure the BMP is effective.
 16. The vegetated area should be established and maintained to ensure the BMP is effective.
 17. The vegetated area should be established and maintained to ensure the BMP is effective.
 18. The vegetated area should be established and maintained to ensure the BMP is effective.
 19. The vegetated area should be established and maintained to ensure the BMP is effective.
 20. The vegetated area should be established and maintained to ensure the BMP is effective.

REVISIONS	BY

EMC
 Engineers/Scientists, LLC
 10000 SW 10th Street, Suite 200, Beaverton, OR 97005
 Phone: 503-640-9999 Fax: 503-640-9998
 Email: info@emc-es.com

PORT OF BROOKINGS HARBOR
BOAT YARD PAVING
 16330 LOWER HARBOR ROAD, BROOKINGS, OR 97415

DESIGN BY:	ES
DATE: 26 JAN 2021	
JOB NO.:	21-001
SHEET NO.:	1

C1.0
 COVER SHEET

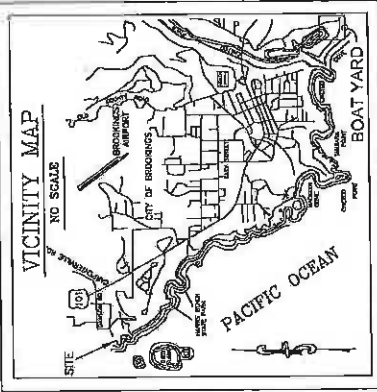

- ### GRADING NOTES
1. PRIOR TO THE COMMENCEMENT OF CONSTRUCTION, THE CONTRACTOR SHALL OBTAIN NECESSARY PERMITS FROM ALL APPLICABLE AGENCIES AND SHALL COMPLY WITH ALL APPLICABLE REGULATIONS AND ORDINANCES. THE CONTRACTOR SHALL BE RESPONSIBLE FOR OBTAINING ALL NECESSARY PERMITS AND SHALL BE RESPONSIBLE FOR THE COST OF OBTAINING SUCH PERMITS. THE CONTRACTOR SHALL BE RESPONSIBLE FOR THE COST OF OBTAINING ALL NECESSARY PERMITS AND SHALL BE RESPONSIBLE FOR THE COST OF OBTAINING SUCH PERMITS.
 2. THE CONTRACTOR SHALL BE RESPONSIBLE FOR OBTAINING ALL NECESSARY PERMITS AND SHALL BE RESPONSIBLE FOR THE COST OF OBTAINING SUCH PERMITS.
 3. THE CONTRACTOR SHALL BE RESPONSIBLE FOR OBTAINING ALL NECESSARY PERMITS AND SHALL BE RESPONSIBLE FOR THE COST OF OBTAINING SUCH PERMITS.
 4. THE CONTRACTOR SHALL BE RESPONSIBLE FOR OBTAINING ALL NECESSARY PERMITS AND SHALL BE RESPONSIBLE FOR THE COST OF OBTAINING SUCH PERMITS.
 5. THE CONTRACTOR SHALL BE RESPONSIBLE FOR OBTAINING ALL NECESSARY PERMITS AND SHALL BE RESPONSIBLE FOR THE COST OF OBTAINING SUCH PERMITS.
 6. THE CONTRACTOR SHALL BE RESPONSIBLE FOR OBTAINING ALL NECESSARY PERMITS AND SHALL BE RESPONSIBLE FOR THE COST OF OBTAINING SUCH PERMITS.
 7. THE CONTRACTOR SHALL BE RESPONSIBLE FOR OBTAINING ALL NECESSARY PERMITS AND SHALL BE RESPONSIBLE FOR THE COST OF OBTAINING SUCH PERMITS.
 8. THE CONTRACTOR SHALL BE RESPONSIBLE FOR OBTAINING ALL NECESSARY PERMITS AND SHALL BE RESPONSIBLE FOR THE COST OF OBTAINING SUCH PERMITS.
 9. THE CONTRACTOR SHALL BE RESPONSIBLE FOR OBTAINING ALL NECESSARY PERMITS AND SHALL BE RESPONSIBLE FOR THE COST OF OBTAINING SUCH PERMITS.
 10. THE CONTRACTOR SHALL BE RESPONSIBLE FOR OBTAINING ALL NECESSARY PERMITS AND SHALL BE RESPONSIBLE FOR THE COST OF OBTAINING SUCH PERMITS.
 11. THE CONTRACTOR SHALL BE RESPONSIBLE FOR OBTAINING ALL NECESSARY PERMITS AND SHALL BE RESPONSIBLE FOR THE COST OF OBTAINING SUCH PERMITS.
 12. THE CONTRACTOR SHALL BE RESPONSIBLE FOR OBTAINING ALL NECESSARY PERMITS AND SHALL BE RESPONSIBLE FOR THE COST OF OBTAINING SUCH PERMITS.
 13. THE CONTRACTOR SHALL BE RESPONSIBLE FOR OBTAINING ALL NECESSARY PERMITS AND SHALL BE RESPONSIBLE FOR THE COST OF OBTAINING SUCH PERMITS.
 14. THE CONTRACTOR SHALL BE RESPONSIBLE FOR OBTAINING ALL NECESSARY PERMITS AND SHALL BE RESPONSIBLE FOR THE COST OF OBTAINING SUCH PERMITS.
 15. THE CONTRACTOR SHALL BE RESPONSIBLE FOR OBTAINING ALL NECESSARY PERMITS AND SHALL BE RESPONSIBLE FOR THE COST OF OBTAINING SUCH PERMITS.
 16. THE CONTRACTOR SHALL BE RESPONSIBLE FOR OBTAINING ALL NECESSARY PERMITS AND SHALL BE RESPONSIBLE FOR THE COST OF OBTAINING SUCH PERMITS.
 17. THE CONTRACTOR SHALL BE RESPONSIBLE FOR OBTAINING ALL NECESSARY PERMITS AND SHALL BE RESPONSIBLE FOR THE COST OF OBTAINING SUCH PERMITS.
 18. THE CONTRACTOR SHALL BE RESPONSIBLE FOR OBTAINING ALL NECESSARY PERMITS AND SHALL BE RESPONSIBLE FOR THE COST OF OBTAINING SUCH PERMITS.
 19. THE CONTRACTOR SHALL BE RESPONSIBLE FOR OBTAINING ALL NECESSARY PERMITS AND SHALL BE RESPONSIBLE FOR THE COST OF OBTAINING SUCH PERMITS.
 20. THE CONTRACTOR SHALL BE RESPONSIBLE FOR OBTAINING ALL NECESSARY PERMITS AND SHALL BE RESPONSIBLE FOR THE COST OF OBTAINING SUCH PERMITS.

GEOTECHNICAL NOTE

THE CONTRACTOR SHALL OBTAIN ALL NECESSARY PERMITS AND SHALL BE RESPONSIBLE FOR THE COST OF OBTAINING SUCH PERMITS. THE CONTRACTOR SHALL BE RESPONSIBLE FOR THE COST OF OBTAINING ALL NECESSARY PERMITS AND SHALL BE RESPONSIBLE FOR THE COST OF OBTAINING SUCH PERMITS.

SHEET INDEX

C1.0	COVER SHEET
C2.0	EXISTING CONDITIONS
C3.0	GRADING PLAN
C4.0	PAVEMENT AREA
C5.0	STORMWATER CONVEYANCE
C6.0	NOT USED
C7.0	PROJECT DETAILS



REVISIONS	BY

EMC
 Engineers, LLC
 10000 Old County Road, Suite 200, Orlando, FL 32837
 407.351.1111
 www.emc-engineers.com



PORT OF BROOKINGS HARBOR
 BOAT YARD PAVING
 18390 LOWER HARBOR ROAD, BROOKINGS, OR 97415

DRAWN BY: JG
 DATE: 26 JAN 2023
 SHEET NO.: 2
 C2.0
 EXISTING
 CONDITIONS

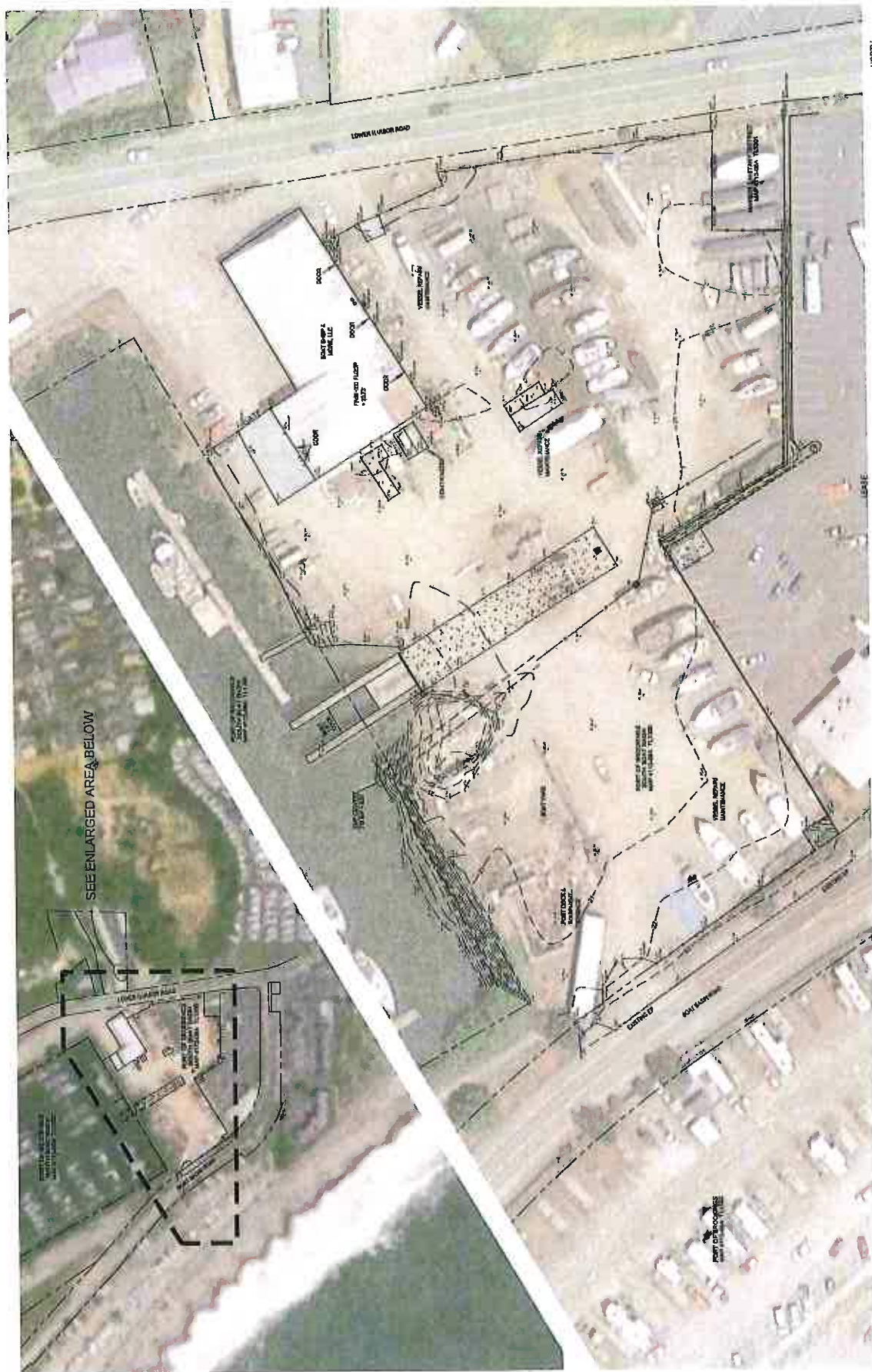

SEE ENLARGED AREA BELOW



EXISTING CONDITIONS
 SCALE: 1" = 20'



VERTICAL DATUM
 MEAN SEA LEVEL (MSL) WITH TIDE GAUGE
 DATUM FOR ELEVATIONS AND SPOTS
 ELEVATIONS ARE IN FEET

HORIZONTAL DATUM
 NAD 83
 HORIZONTAL DATUM IS NAD 83
 HORIZONTAL DATUM IS NAD 83
 HORIZONTAL DATUM IS NAD 83
 HORIZONTAL DATUM IS NAD 83

SURVEY BY
 EMC ENGINEERS, LLC
 10000 OLD COUNTY ROAD, SUITE 200
 ORLANDO, FL 32837
 407.351.1111
 www.emc-engineers.com

REVISIONS	BY:

EMC Engineers/Scientists, LLC
 10000 S.W. 10th Street, Suite 210, Miami, FL 33154
 Phone: (305) 555-1111 Fax: (305) 555-1112
 Email: info@emc-sc.com
 Florida Professional Engineer License No. 12584
 Florida Professional Scientist License No. 12584



PORT OF BROOKINGS HARBOR
 16330 LOWER HARBOR ROAD, BROOKINGS, OR 97415
BOAT YARD PAVING

DRAWN BY: JS
 DATE: 26 JAN 2021
 JOB NO:
 SHEET NO: **C2.1**
 GRADING PLAN

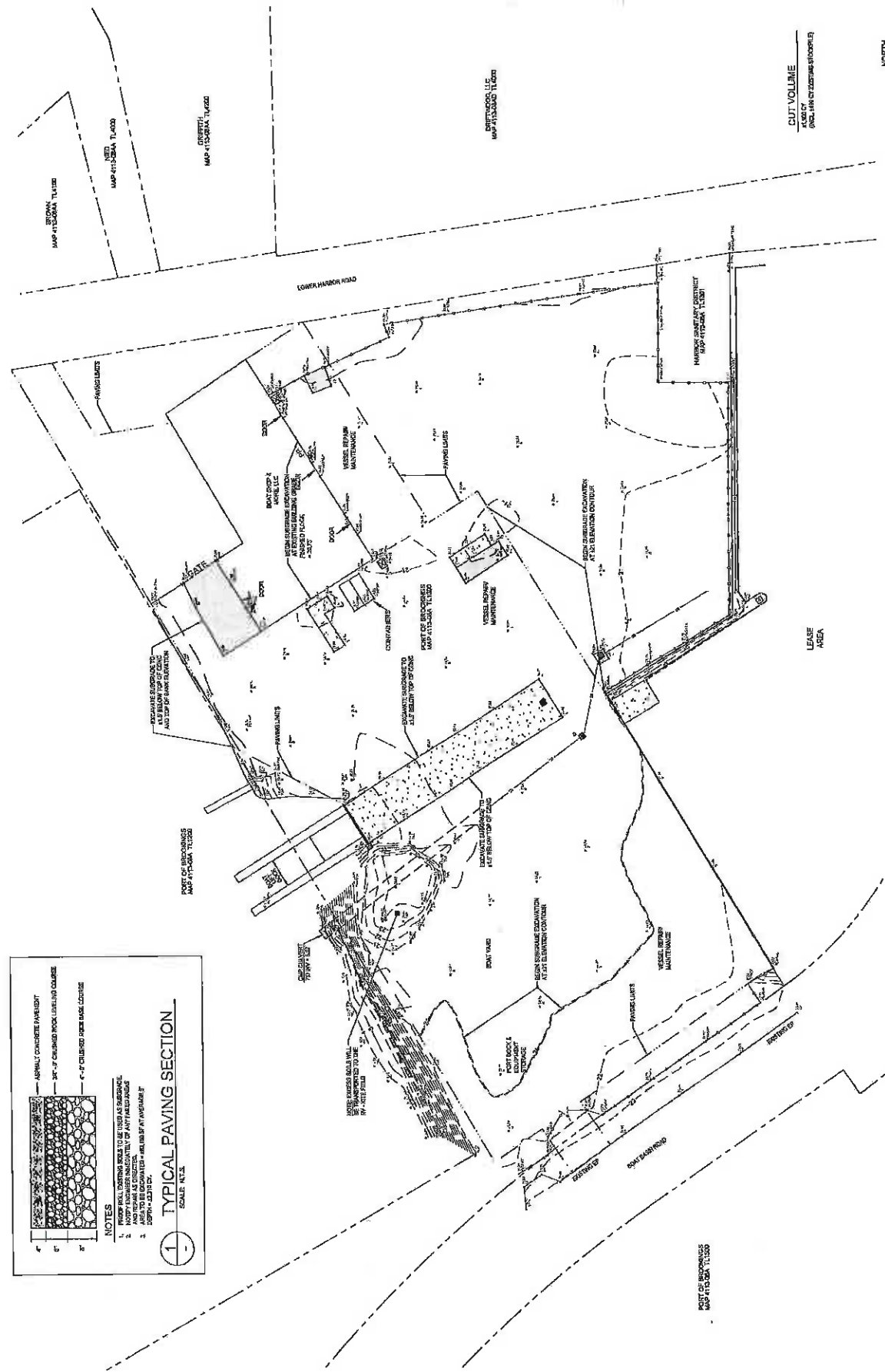

TYPICAL PAVING SECTION
 SCALE: N.T.S.

NOTES

- PROPOSED DRAINAGE SHALL BE USED AS SUBGRADE.
- ALL PAVING SHALL BE CONSTRUCTED TO THE FINISH ELEVATION.
- CONSTRUCTION SHALL BE IN ACCORDANCE WITH THE SPECIFICATIONS.



GRADING PLAN
 SCALE: 1" = 30'



CUT VOLUME
 (INCLUDES CUT EXISTING STOCKPILE)

NO.	DATE	REVISIONS

EMC Engineers/Scientists, LLC
 16330 LOWER HARBOR ROAD, BROOKINGS, OR 97415
 PHONE: 541-338-8800 FAX: 541-338-8801
 WWW.EMCSOCIETY.COM



PORT OF BROOKINGS HARBOR
 BOAT YARD PAVING
 16330 LOWER HARBOR ROAD, BROOKINGS, OR 97415
 DRAWN BY: JAC
 DATE: 28 JAN 2021
 JOB NO.:
 SHEET NO.: **C3.0**
 PAYMENT AREAS

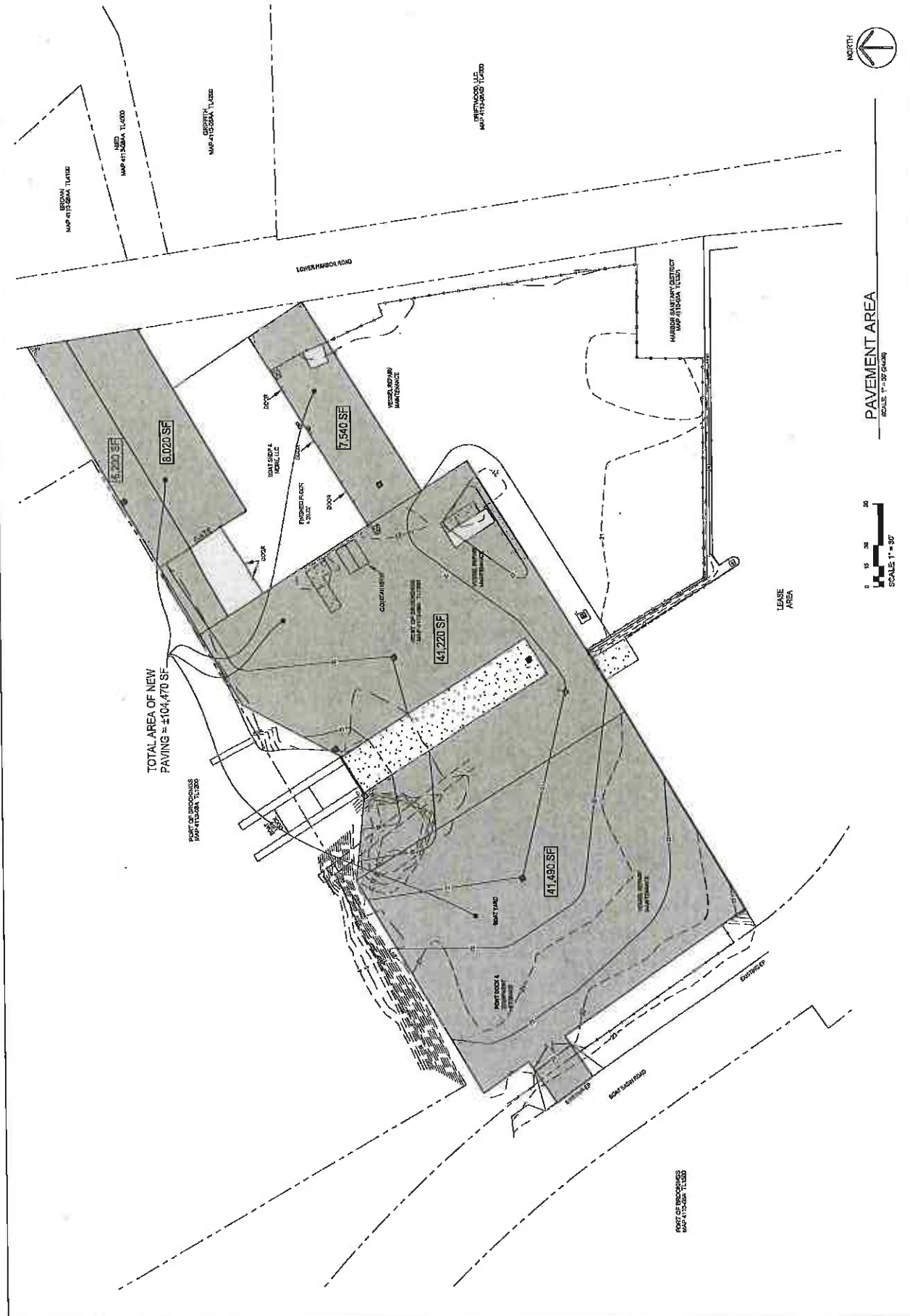



STORMWATER CONVEYANCE
SCALE: 1" = 30'

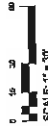

DRAWN BY: JG
DATE: 26 JAN 2021
JOB No.:
SHEET No.:
C4.0
STORMWATER
CONVEYANCE

PORT OF BROOKINGS HARBOR
16330 LOWER HARBOR ROAD, BROOKINGS, OR 97415
BOAT YARD PAVING



EMC Engineers/Scientists, LLC
3700 NE Oregon Street, Suite 200, Medford, OR 97504
Tel: 541-754-1234 Fax: 541-754-5678
www.emc-engineers.com

NO.	REVISIONS

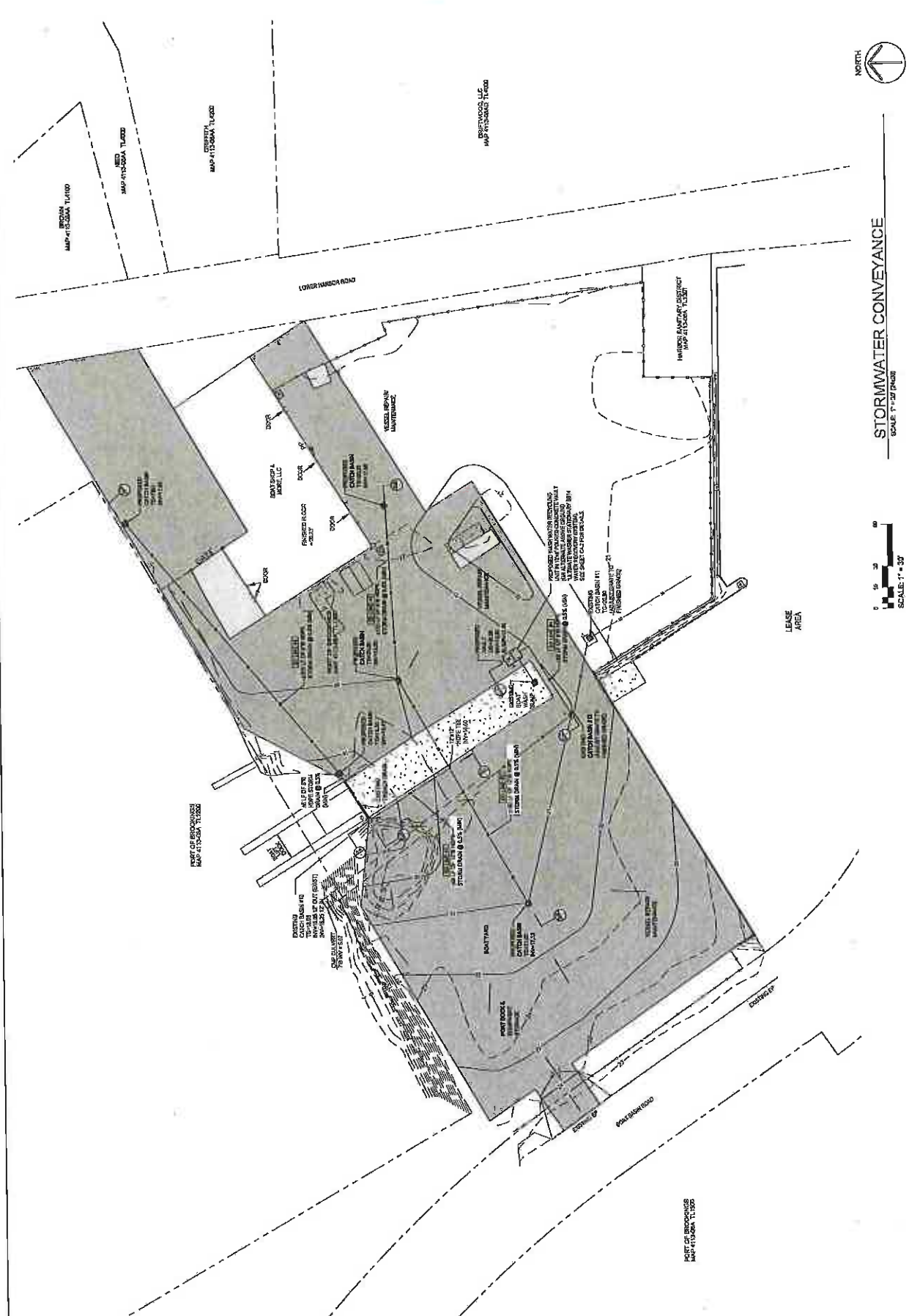

PORT OF BROOKINGS
MAP 411000A, 11.1505

REVISIONS	BY

EMC Engineers & Scientists, LLC
 4700 Old York Road, Suite 200, York, PA 17403
 P: 717-765-1100 F: 717-765-1101
 www.emc-engineers.com



PORT OF BROOKINGS HARBOR
 16300 LOWER HARBOR ROAD, BROOKINGS, OR 97415
 BOAT YARD PAVING

DRAWN BY: JG
 DATE: 26 JAN 2024
 JOB NO: 24001
 SHEET NO: **C4.1**
 STORMDRAIN PROFILES

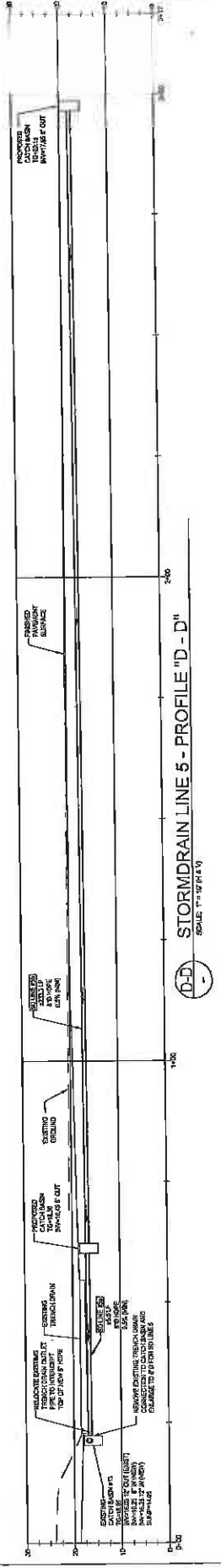
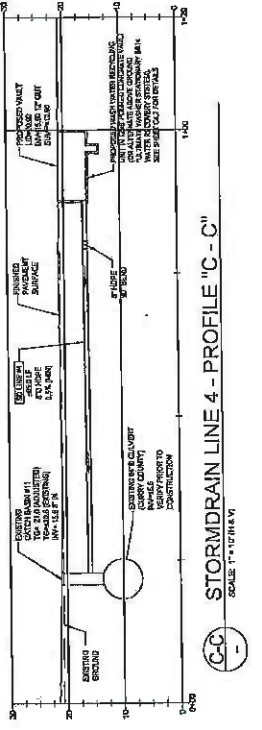
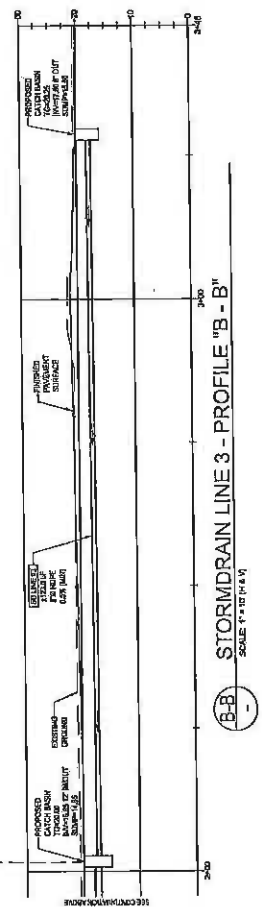
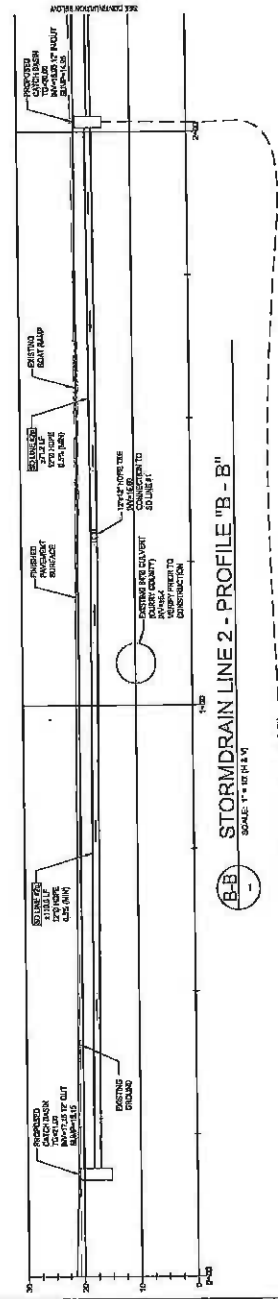
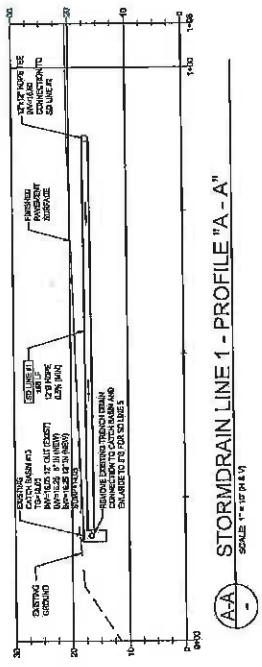

332

REVISIONS	BY:	

EMC
 Engineers/Scientists, LLC
 1330 Lower Harbor Road, Brookings, OR 97415
 Phone: (541) 338-2222
 Fax: (541) 338-2223
 Email: info@emc-sc.com
 Website: www.emc-sc.com



PORT OF BROOKINGS HARBOR
 BOAT YARD PAVING
 1330 LOWER HARBOR ROAD, BROOKINGS, OR 97415

DRAWN BY: JG
 DATE: 20 JAN 2021
 JOB No.:
 SHEET No.:
C42
 WASHWATER RECYCLING DETAILS

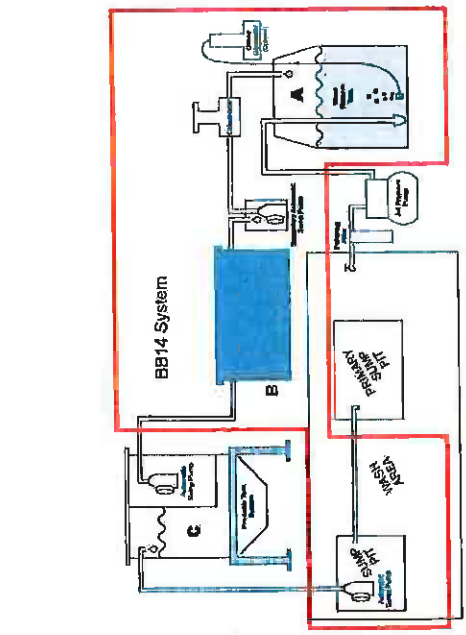

ULTIMATE WASHWATER STATIONARY BB14 WATER RECOVERY SYSTEM



- 1. ALL ELECTRICAL WORK SHALL BE PERFORMED BY A LICENSED ELECTRICIAN.
- 2. ALL PIPING SHALL BE 1/2" DIA. POLYETHYLENE GLYCOL (PE) PIPE.
- 3. ALL PIPING SHALL BE INSTALLED IN ACCORDANCE WITH THE MANUFACTURER'S INSTALLATION INSTRUCTIONS.
- 4. ALL PIPING SHALL BE INSTALLED IN ACCORDANCE WITH THE MANUFACTURER'S INSTALLATION INSTRUCTIONS.
- 5. ALL PIPING SHALL BE INSTALLED IN ACCORDANCE WITH THE MANUFACTURER'S INSTALLATION INSTRUCTIONS.
- 6. ALL PIPING SHALL BE INSTALLED IN ACCORDANCE WITH THE MANUFACTURER'S INSTALLATION INSTRUCTIONS.
- 7. ALL PIPING SHALL BE INSTALLED IN ACCORDANCE WITH THE MANUFACTURER'S INSTALLATION INSTRUCTIONS.
- 8. ALL PIPING SHALL BE INSTALLED IN ACCORDANCE WITH THE MANUFACTURER'S INSTALLATION INSTRUCTIONS.
- 9. ALL PIPING SHALL BE INSTALLED IN ACCORDANCE WITH THE MANUFACTURER'S INSTALLATION INSTRUCTIONS.
- 10. ALL PIPING SHALL BE INSTALLED IN ACCORDANCE WITH THE MANUFACTURER'S INSTALLATION INSTRUCTIONS.

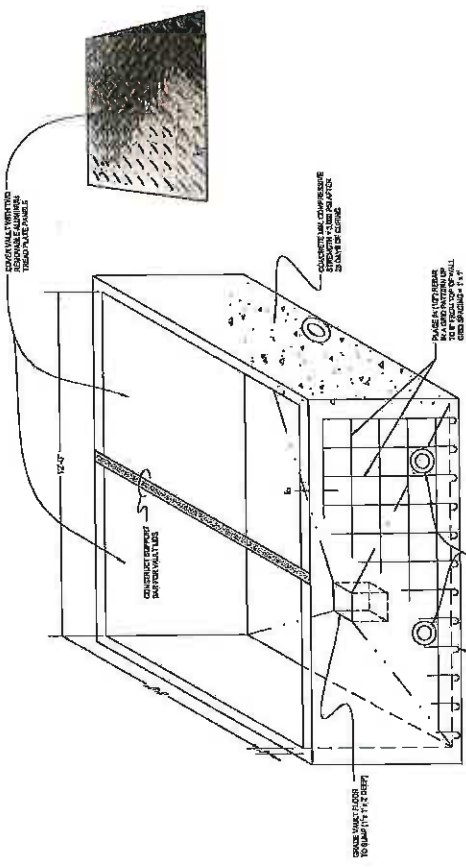

PRELIMINARY WASHWATER RECYCLING VAULT

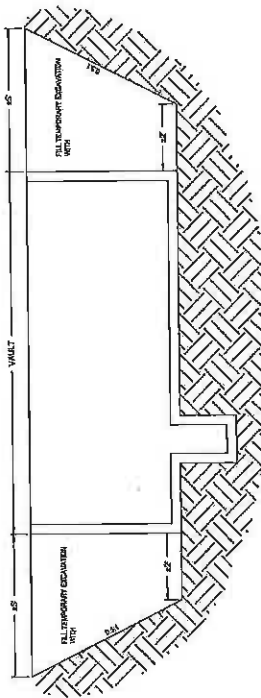

PRELIMINARY WASHWATER RECYCLING VAULT

2

ALTERNATE ABOVE-GROUND WASHWATER RECYCLING UNIT

SCALE: N.T.S.

1

PRELIMINARY WASHWATER RECYCLING VAULT

SCALE: N.T.S.

REVISIONS	BY:

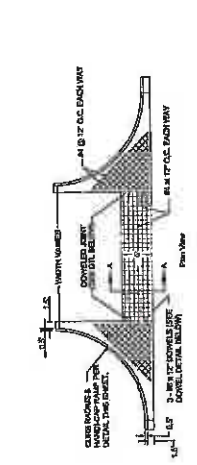

300 ROLLED CURB
SCALE: 1/8\"/>

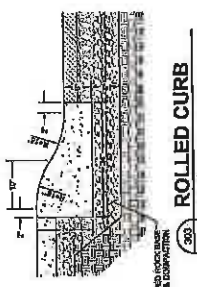

301 VERTICAL CURB
SCALE: 1/8\"/>

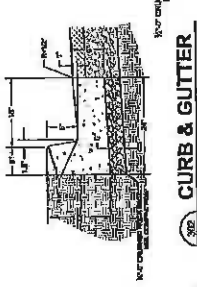

302 CURB & GUTTER
SCALE: 1/8\"/>

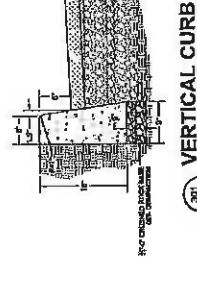

303 CURB LINE CONCRETE SIDEWALK
SCALE: 1/8\"/>

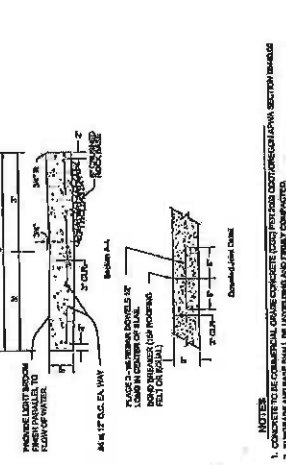

304 DRIVEWAY APRON WITH VALLEY GUTTER
SCALE: 1/8\"/>

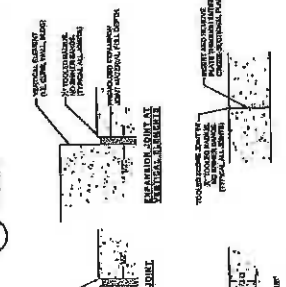

305 CONCRETE CONTROL JOINTS
SCALE: 1/8\"/>

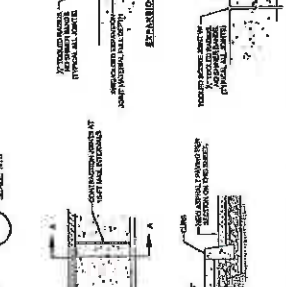

306 WHEEL STOP
SCALE: 1/8\"/>

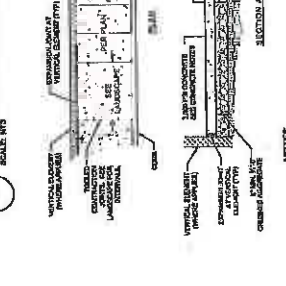

307 CURB TAPER
SCALE: 1/8\"/>

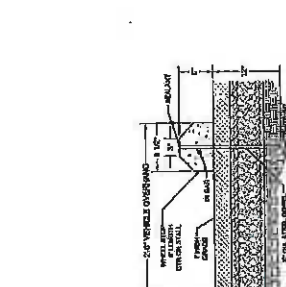

308 CONDUIT TRENCH DETAIL
SCALE: 1/8\"/>



309 WATER TRENCH DETAIL
SCALE: 1/8\"/>



310 JOINT TRENCH DETAIL
SCALE: 1/8\"/>



311 SEWER TRENCH DETAIL
SCALE: 1/8\"/>



312 CONDUIT TRENCH DETAIL
SCALE: 1/8\"/>

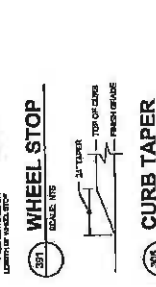

313 CONDUIT TRENCH DETAIL
SCALE: 1/8\"/>

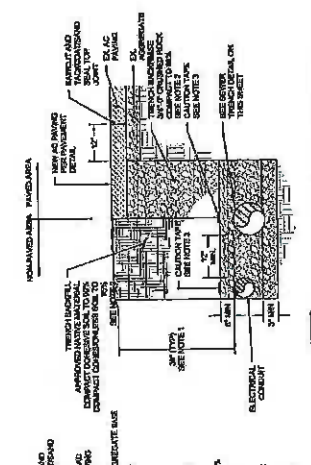

314 CONDUIT TRENCH DETAIL
SCALE: 1/8\"/>

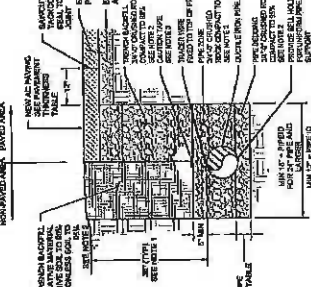

315 CONDUIT TRENCH DETAIL
SCALE: 1/8\"/>

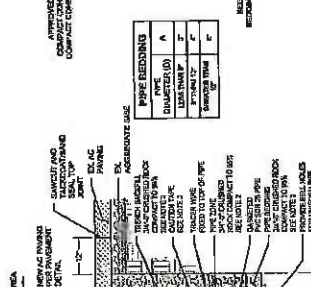

316 CONDUIT TRENCH DETAIL
SCALE: 1/8\"/>

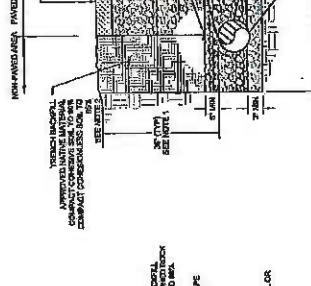

317 CONDUIT TRENCH DETAIL
SCALE: 1/8\"/>

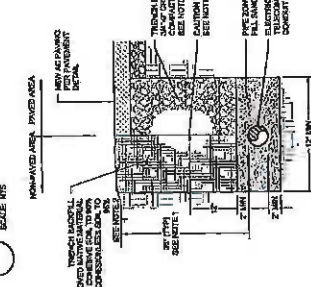

318 CONDUIT TRENCH DETAIL
SCALE: 1/8\"/>

NOTES:

- CONCRETE SHALL BE 4000 PSI COMPRESSIVE STRENGTH, 3% AIR ENTRAINMENT, AND SHALL BE PLACED AND FINISHED TO ASSURE FLAT.
- WALKER GUTTERS SHALL BE INSTALLED IN ACCORDANCE WITH MANUFACTURER'S INSTRUCTIONS.
- SEE NOTES 1-3 FOR GUTTER INSTALLATION.

NOTES:

- CONCRETE SHALL BE 4000 PSI COMPRESSIVE STRENGTH, 3% AIR ENTRAINMENT, AND SHALL BE PLACED AND FINISHED TO ASSURE FLAT.
- WALKER GUTTERS SHALL BE INSTALLED IN ACCORDANCE WITH MANUFACTURER'S INSTRUCTIONS.
- SEE NOTES 1-3 FOR GUTTER INSTALLATION.

NOTES:

- CONCRETE SHALL BE 4000 PSI COMPRESSIVE STRENGTH, 3% AIR ENTRAINMENT, AND SHALL BE PLACED AND FINISHED TO ASSURE FLAT.
- WALKER GUTTERS SHALL BE INSTALLED IN ACCORDANCE WITH MANUFACTURER'S INSTRUCTIONS.
- SEE NOTES 1-3 FOR GUTTER INSTALLATION.

NOTES:

- CONCRETE SHALL BE 4000 PSI COMPRESSIVE STRENGTH, 3% AIR ENTRAINMENT, AND SHALL BE PLACED AND FINISHED TO ASSURE FLAT.
- WALKER GUTTERS SHALL BE INSTALLED IN ACCORDANCE WITH MANUFACTURER'S INSTRUCTIONS.
- SEE NOTES 1-3 FOR GUTTER INSTALLATION.

NOTES:

- CONCRETE SHALL BE 4000 PSI COMPRESSIVE STRENGTH, 3% AIR ENTRAINMENT, AND SHALL BE PLACED AND FINISHED TO ASSURE FLAT.
- WALKER GUTTERS SHALL BE INSTALLED IN ACCORDANCE WITH MANUFACTURER'S INSTRUCTIONS.
- SEE NOTES 1-3 FOR GUTTER INSTALLATION.

REVISIONS	BY:

EMC
 Engineers, Scientists, LLC
 10000 Old County Road, Suite 100
 San Diego, CA 92126
 Tel: 619-444-2200
 Fax: 619-444-2201
 Email: info@emc-engineers.com



PORT OF BROOKINGS HARBOR
 BOAT YARD PAVING
 15330 LOWER HARBOR ROAD, BROOKINGS, OR 97415

DRAWN BY: JG
 DATE: 28 JAN 2011
 JOB NO: #
 SHEET NO: #
C6.1
 PROJECT
 DETAILS

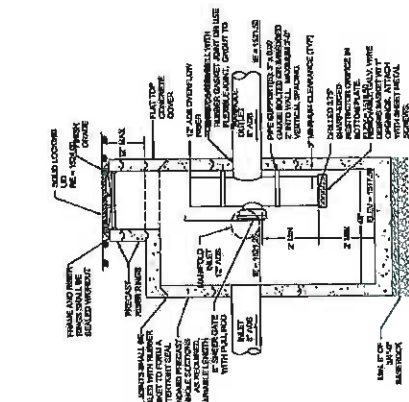

4 CONTROL STRUCTURE MANHOLE
 SCALE: 1/8" = 1'-0"

NOTE:
 ALL PRODUCT SECTIONS SHALL CONFORM TO REQUIREMENTS OF AISC 360-10.

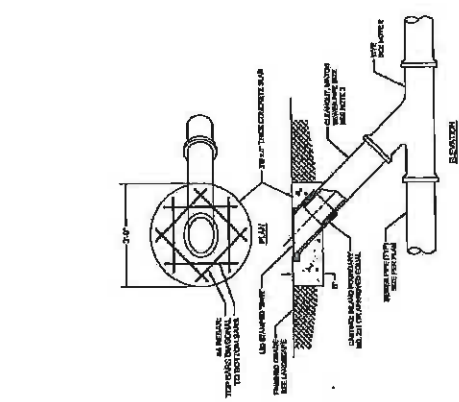

5 TYPICAL CLEANOUT
 SCALE: 1/8" = 1'-0"

NOTE:
 ALL PRODUCT SECTIONS SHALL CONFORM TO REQUIREMENTS OF AISC 360-10.

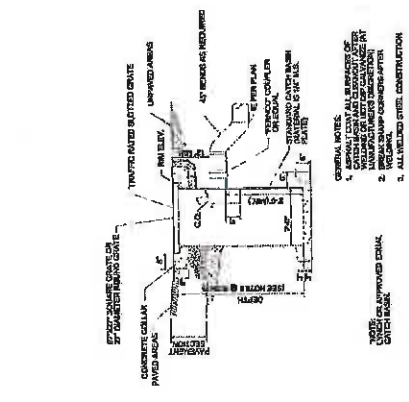

6 LYNCH STYLE CATCH BASIN
 SCALE: 1/8" = 1'-0"

NOTE:
 ALL PRODUCT SECTIONS SHALL CONFORM TO REQUIREMENTS OF AISC 360-10.

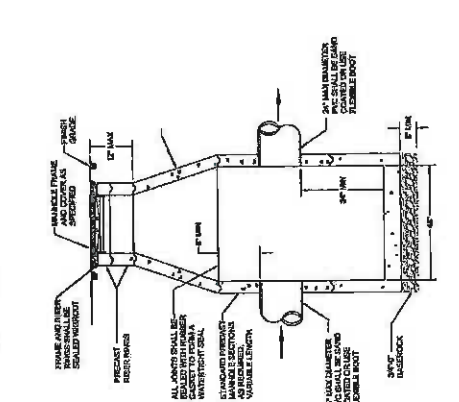

7 48" STORM MANHOLE
 SCALE: 1/8" = 1'-0"

NOTE:
 ALL PRODUCT SECTIONS SHALL CONFORM TO REQUIREMENTS OF AISC 360-10.

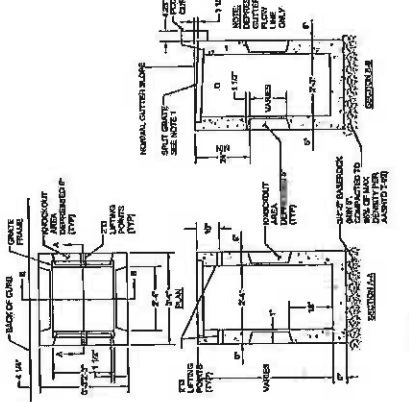

8 CATCH BASIN
 SCALE: 1/8" = 1'-0"

NOTE:
 ALL PRODUCT SECTIONS SHALL CONFORM TO REQUIREMENTS OF AISC 360-10.

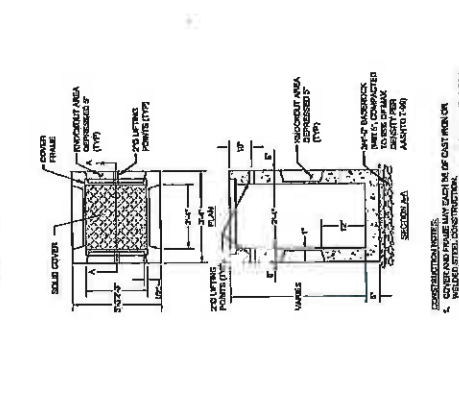

9 JUNCTION BASIN
 SCALE: 1/8" = 1'-0"

NOTE:
 ALL PRODUCT SECTIONS SHALL CONFORM TO REQUIREMENTS OF AISC 360-10.

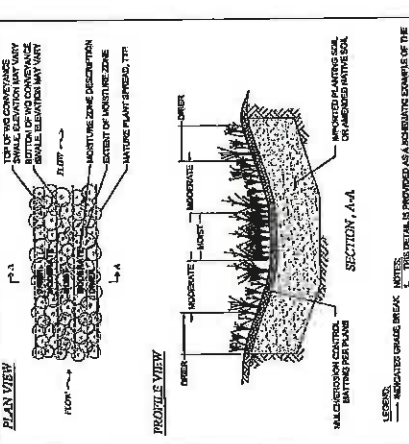

10 VEGETATION ZONE
 SCALE: 1/8" = 1'-0"

NOTE:
 ALL PRODUCT SECTIONS SHALL CONFORM TO REQUIREMENTS OF AISC 360-10.

Rocky Valley Wetland BMPs
 Planning Schematic
 Scale: NTS

1. PURPOSE AND SCOPE:
 The purpose of this document is to provide a planning schematic for the Rocky Valley Wetland BMPs. The schematic is intended to be used as a guide for the design and construction of the BMPs.

2. DESIGN CRITERIA:
 The design criteria for the BMPs are based on the following assumptions:
 a. The BMPs are designed to treat runoff from a 10-acre watershed.
 b. The BMPs are designed to reduce sediment and nutrient loading to the receiving water body.
 c. The BMPs are designed to provide habitat for wildlife and fish.

3. BMP TYPES:
 The BMPs are categorized into the following types:
 a. Vegetation BMPs: Grassed waterway, riparian buffer, wetland.
 b. Structural BMPs: Sediment trap, check dam, stone structure.
 c. Best Management Practices (BMPs): No-till, cover crops, buffer strips.

4. CONSTRUCTION AND MAINTENANCE:
 The construction and maintenance of the BMPs should follow the following guidelines:
 a. Construction should be completed within 12 months of the start of the project.
 b. Maintenance should be performed annually to ensure the BMPs are functioning properly.

5. MONITORING AND EVALUATION:
 The BMPs should be monitored and evaluated on a regular basis to ensure they are meeting the design objectives.



PORT OF BROOKINGS HARBOR

KITE FIELD RV PARK



KITE FIELD PARK EXTENTS



PROJECT OVERVIEW

SCALE: 1"=60' (PLAN) 1"=60' (ELEV.)

DRAWING REGISTER

NO.	DESCRIPTION
C1.0	COVER SHEET
C1.1	EXISTING CONDITIONS
C2.0	SEQUENCING
C2.1	SEQUENCING
C2.2	SEQUENCING
C2.3	SEQUENCING DETAILS
C3.0	PRELIMINARY RV PARK DESIGN
C4.0	ROAD SECTIONS
C5.0	GENERAL NOTES
C5.1	PCS STANDARD DETAILS
C5.2	PCS GENERAL NOTES

THIS DRAWING AND THE INFORMATION CONTAINED HEREIN ARE THE PROPERTY OF EMC ENGINEERING, INC. AND ARE TO BE USED ONLY FOR THE PROJECT AND SITE SPECIFICALLY IDENTIFIED HEREIN. ANY REUSE OR MODIFICATION OF THIS DRAWING WITHOUT THE WRITTEN CONSENT OF EMC ENGINEERING, INC. IS STRICTLY PROHIBITED. THE USER ASSUMES ALL LIABILITY FOR ANY DAMAGE, LOSS, OR INJURY RESULTING FROM THE USE OF THIS DRAWING.

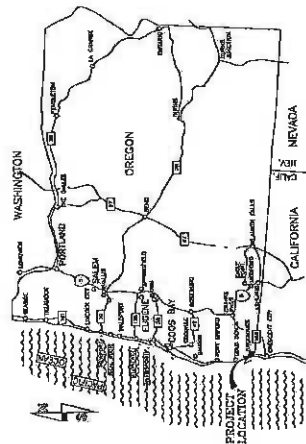

LOCATION MAP

LEGEND:

▲	FIRE HYDRANT	▲	NEW CONCRETE
□	WATER VALVE	▲	NEW BRICK PAVING
■	WATER METER	▲	NEW TRAFFIC PAVING - STANDARD
■	SEWER METER	▲	NEW TRAFFIC PAVING - HEAVY
■	SEWER RELEASE VALVE	▲	NEW LANDSCAPING
■	ASB RELEASE VALVE	▲	NEW RYBAT RAMP
■	GLASSIFY DEVICE ASSEMBLY	▲	
■	PRE DEPARTMENT CONNECTION	▲	
■	END FLAG	▲	
■	TIE	▲	
■	SANITARY SEWER CLEANOUT	▲	
■	SANITARY SEWER MANHOLE	▲	
■	STORM DRAIN CLEANOUT	▲	
■	STORM DRAIN MANHOLE	▲	
■	ATRIUM DRAIN SUBMER	▲	
■	CHIMNEY FLUE	▲	
■	CHIMNEY FLUE	▲	
■	STORM DRAIN CONTROL STRUCTURE	▲	
■	ELECTRIC TRANSFORMER	▲	
■	LIGHTS	▲	
■	REBAR/REINFORCING	▲	
■	WORKMENT	▲	
■	TRIP/SPINAL LIGHT	▲	
■	SIGN (TRAFFIC, INFORMATION)	▲	
■	ISLAND	▲	
■	BICYCLE PAVING SPACE	▲	
■	DECIDUOUS TREE	▲	
■	CONIFER TREE	▲	
■	NEW CONCRETE	▲	
■	NEW BRICK PAVING	▲	
■	NEW TRAFFIC PAVING - STANDARD	▲	
■	NEW TRAFFIC PAVING - HEAVY	▲	
■	NEW LANDSCAPING	▲	
■	NEW RYBAT RAMP	▲	
■	EXIST. FIRE HYDRANT	▲	
■	EXIST. WATER VALVE	▲	
■	EXIST. WATER METER	▲	
■	EXIST. SEWER METER	▲	
■	EXIST. SEWER RELEASE VALVE	▲	
■	EXIST. ASB RELEASE VALVE	▲	
■	EXIST. GLASSIFY DEVICE ASSEMBLY	▲	
■	EXIST. PRE DEPARTMENT CONNECTION	▲	
■	EXIST. END FLAG	▲	
■	EXIST. TIE	▲	
■	EXIST. SANITARY SEWER CLEANOUT	▲	
■	EXIST. SANITARY SEWER MANHOLE	▲	
■	EXIST. STORM DRAIN CLEANOUT	▲	
■	EXIST. STORM DRAIN MANHOLE	▲	
■	EXIST. ATRIUM DRAIN SUBMER	▲	
■	EXIST. CHIMNEY FLUE	▲	
■	EXIST. CHIMNEY FLUE	▲	
■	EXIST. STORM DRAIN CONTROL STRUCTURE	▲	
■	EXIST. ELECTRIC TRANSFORMER	▲	
■	EXIST. LIGHTS	▲	
■	EXIST. REBAR/REINFORCING	▲	
■	EXIST. WORKMENT	▲	
■	EXIST. TRIP/SPINAL LIGHT	▲	
■	EXIST. SIGN (TRAFFIC, INFORMATION)	▲	
■	EXIST. ISLAND	▲	
■	EXIST. BICYCLE PAVING SPACE	▲	
■	EXIST. DECIDUOUS TREE	▲	
■	EXIST. CONIFER TREE	▲	
■	EXIST. NEW CONCRETE	▲	
■	EXIST. NEW BRICK PAVING	▲	
■	EXIST. NEW TRAFFIC PAVING - STANDARD	▲	
■	EXIST. NEW TRAFFIC PAVING - HEAVY	▲	
■	EXIST. NEW LANDSCAPING	▲	
■	EXIST. NEW RYBAT RAMP	▲	
■	EXIST. PROPERTY LINE	▲	

EMC ENGINEERING, INC.
1000 N. W. 10th St., Suite 100
Portland, OR 97227
Phone: 503.253.1234
Fax: 503.253.1235
www.emc-engineering.com

PORT OF BROOKINGS HARBOR
KITE FIELD RV PARK
1630 LOWER HARBOR ROAD, BROOKINGS, OREGON 97418

DATE: 17/01/21
JOB NO: 20-XXX
C1.0
PROJECT
DETAILS

NO.	DATE	REVISION



ACTION AREA
 1732' PERIMETER
 105,524 SF AREA

PORT OF BROOKINGS-HARBOR
 EXISTING ACTION AREA

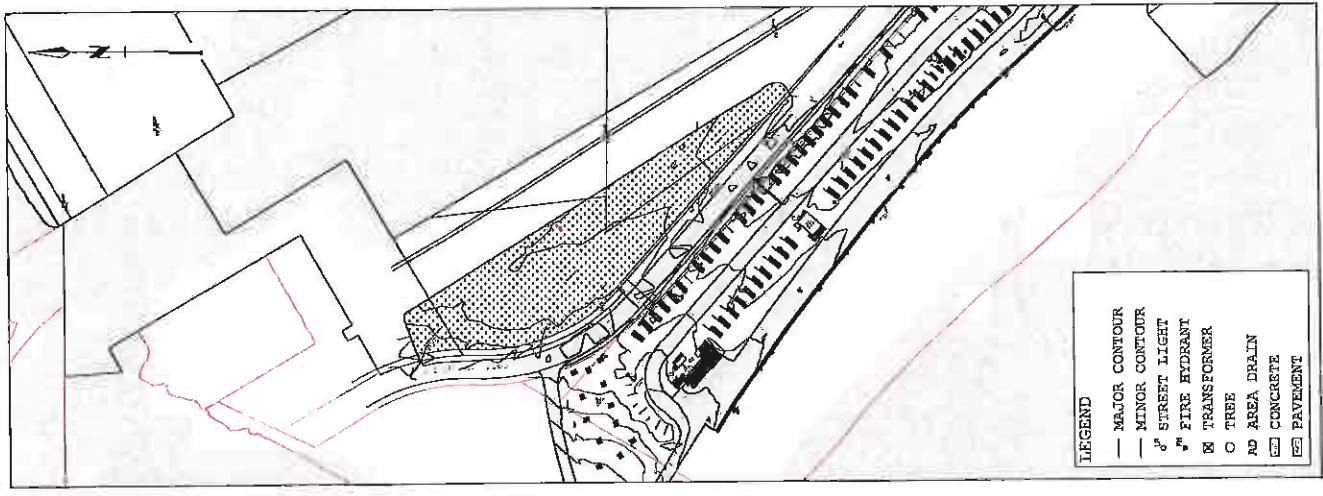

- LEGEND**
- MAJOR CONTOUR
 - MINOR CONTOUR
 - 8" STREET LIGHT
 - 8" FIRE HYDRANT
 - ⊠ TRANSFORMER
 - TREE
 - ▭ ROAD AREA DRAIN
 - ▭ CONCRETE
 - ▭ PAVEMENT

PORT OF BROOKINGS-HARBOR
 TOPOGRAPHIC SURVEY



PORT OF BROOKINGS-HARBOR
 TAX LOTS

REV	DATE	DESCRIPTION

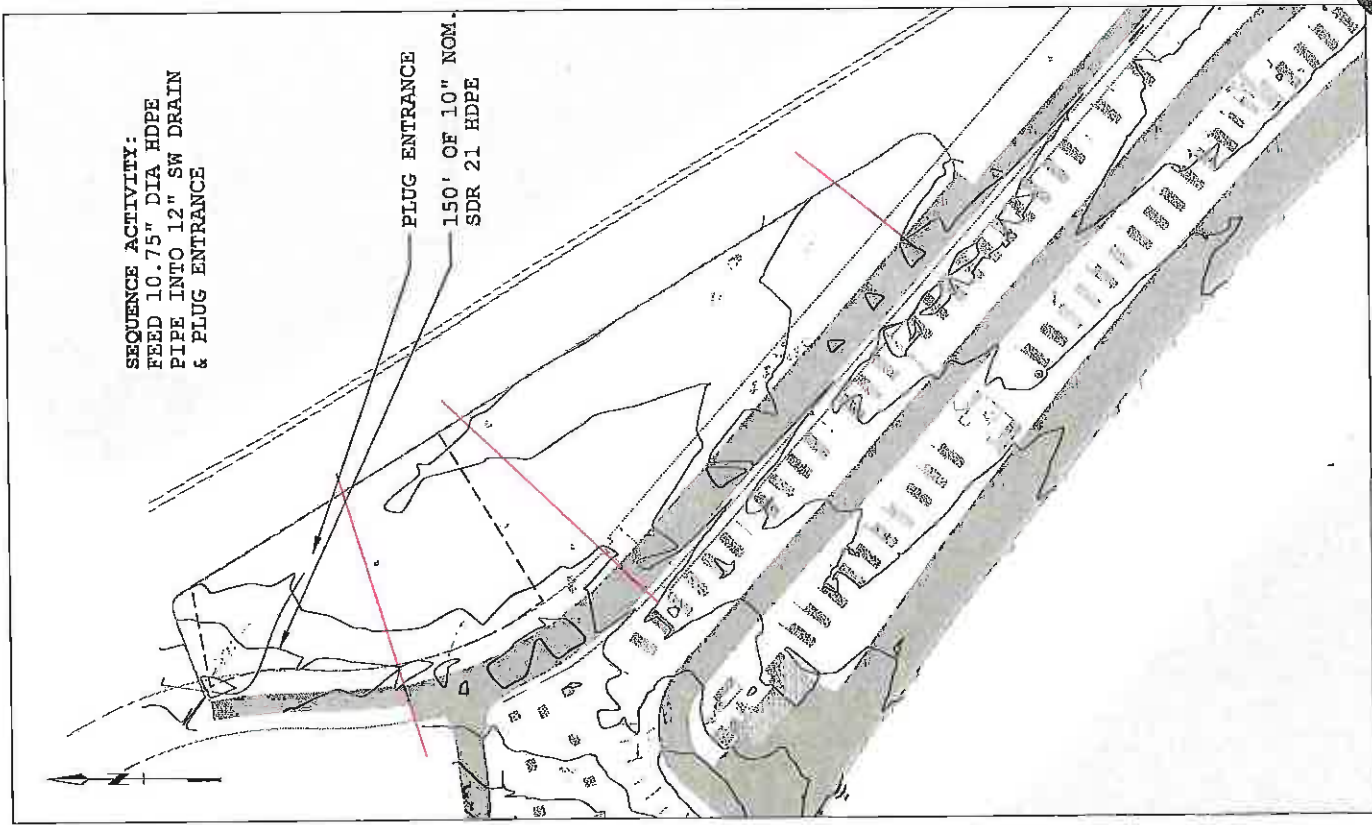

SEQUENCE ACTIVITY:
 FEED 10.75" DIA HDPE
 PIPE INTO 12" SW DRAIN
 & PLUG ENTRANCE

PLUG ENTRANCE
 150' OF 10" NOM.
 SDR 21 HDPE

SEQUENCE #1: SEDIMENT & COLLECTION AREA
 SCALE 1"=80'

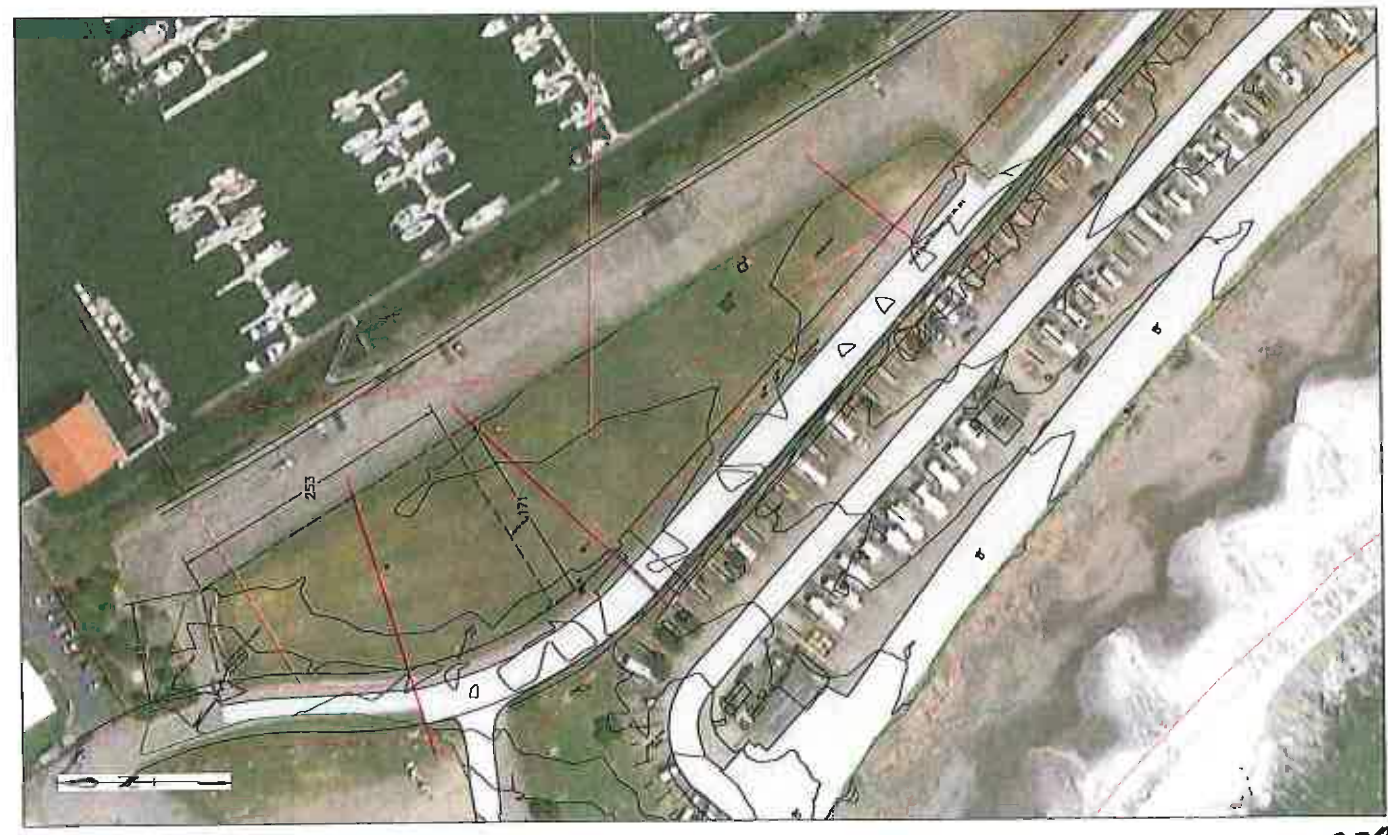

SEQUENCE #0: EXISTING CONDITIONS
 SCALE 1"=80'

NO.	DATE	REVISION

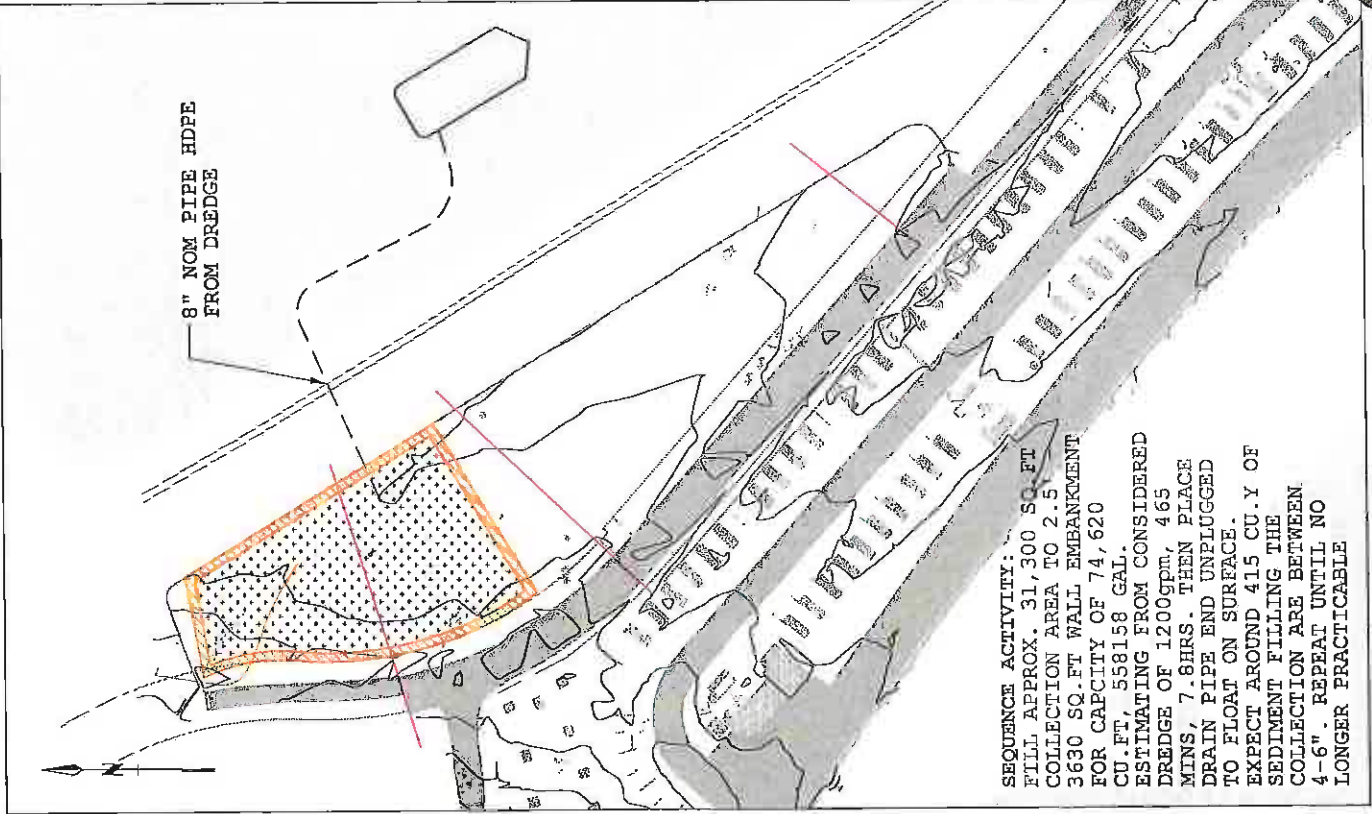

SEQUENCE ACTIVITY:
 FILL APPROX. 31,300 SQ. FT.
 COLLECTION AREA TO 2.5'
 3630 SQ. FT WALL EMBANKMENT
 FOR CAPACITY OF 74,620
 CU. FT. 558158 GAL.
 ESTIMATING FROM CONSIDERED
 DREDGE OF 1200gpm, 465
 MINS, 7.8HRS. THEN PLACE
 DRAIN PIPE END UNPLUGGED
 TO FLOAT ON SURFACE.
 EXPECT AROUND 415 CU. Y OF
 SEDIMENT FILLING THE
 COLLECTION ARE BETWEEN
 4-6". REPEAT UNTIL NO
 LONGER PRACTICABLE

SEQUENCE #3: FILLING PART 1
 SCALE 1"=80'

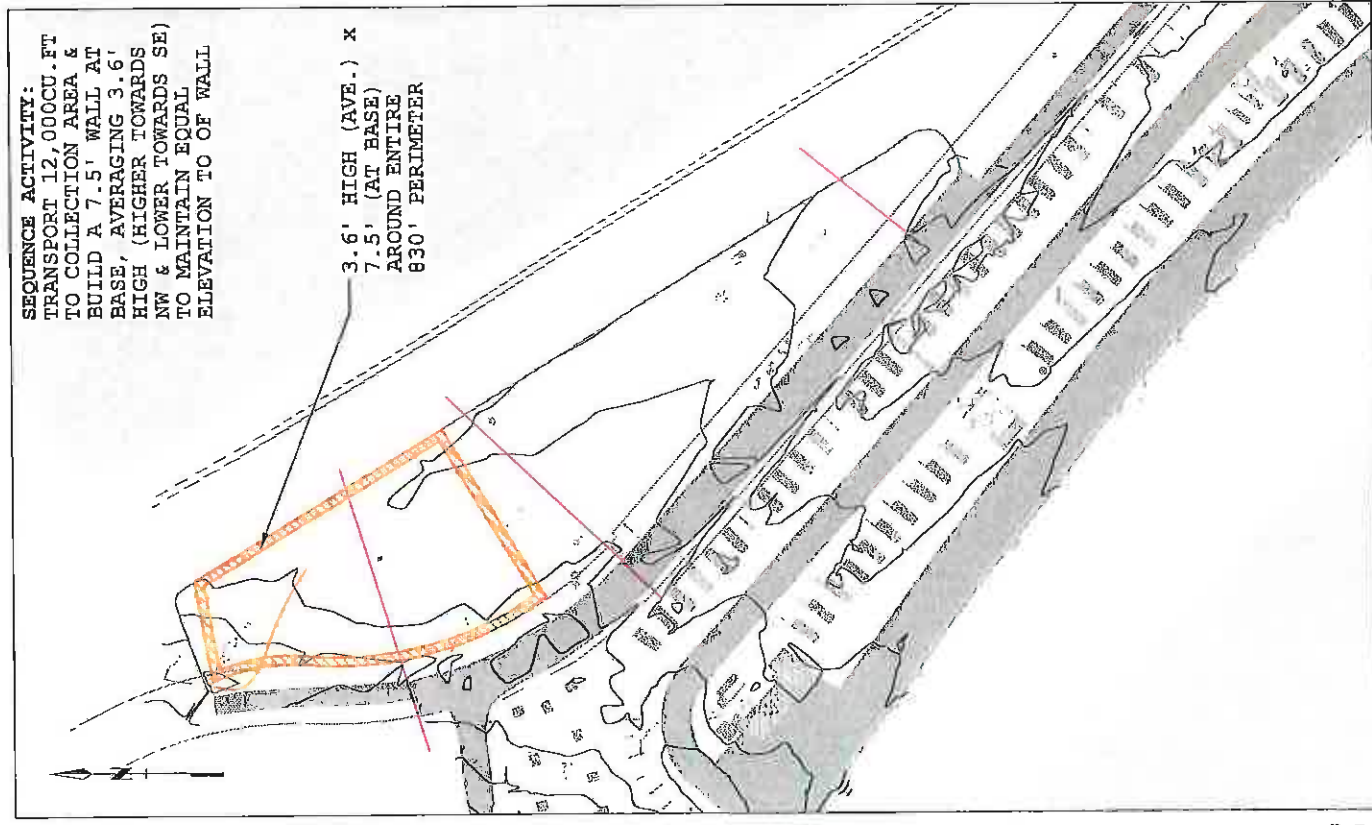

SEQUENCE ACTIVITY:
 TRANSPORT 12,000CU. FT
 TO COLLECTION AREA &
 BUILD A 7.5' WALL AT
 BASE, AVERAGING 3.6'
 HIGH (HIGHER TOWARDS
 NW & LOWER TOWARDS SE)
 TO MAINTAIN EQUAL
 ELEVATION TO OF WALL

3.6' HIGH (AVE.) X
 7.5' (AT BASE)
 AROUND ENTIRE
 830' PERIMETER

SEQUENCE #2: PERIMETER WALL
 SCALE 1"=80'

NO.	DATE	REVISION



SEQUENCE ACTIVITY:
 ACHIEVE FINAL GRADE,
 COMPACTING TO 1FT
 LIFTS TO 95%

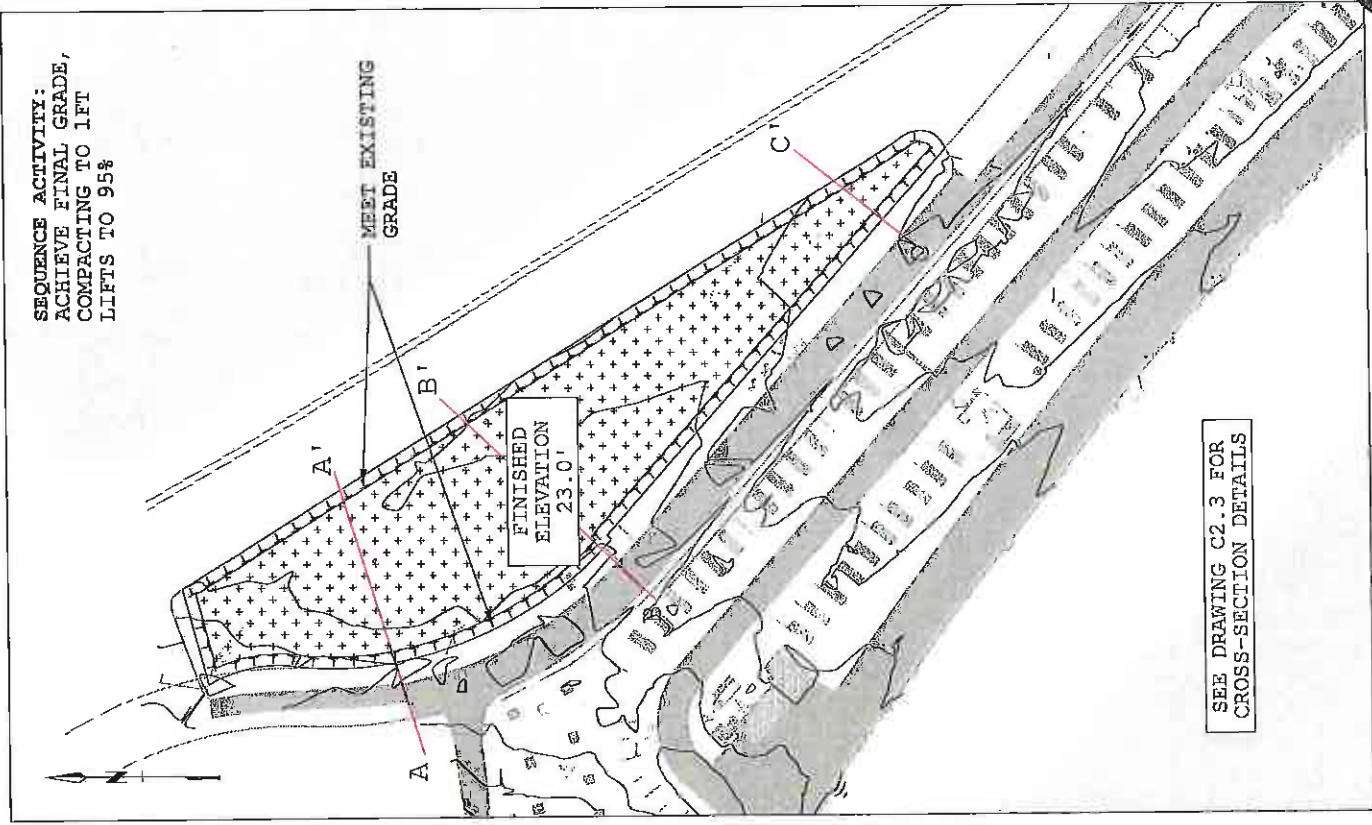

SEQUENCE #5: GRADING AND COMPACTION
 SCALE 1" : 80'

SEQUENCE ACTIVITY:
 TRANSPORT DRAINED
 MATERIAL TO OBTAIN
 SPECIFIED ELEVATION

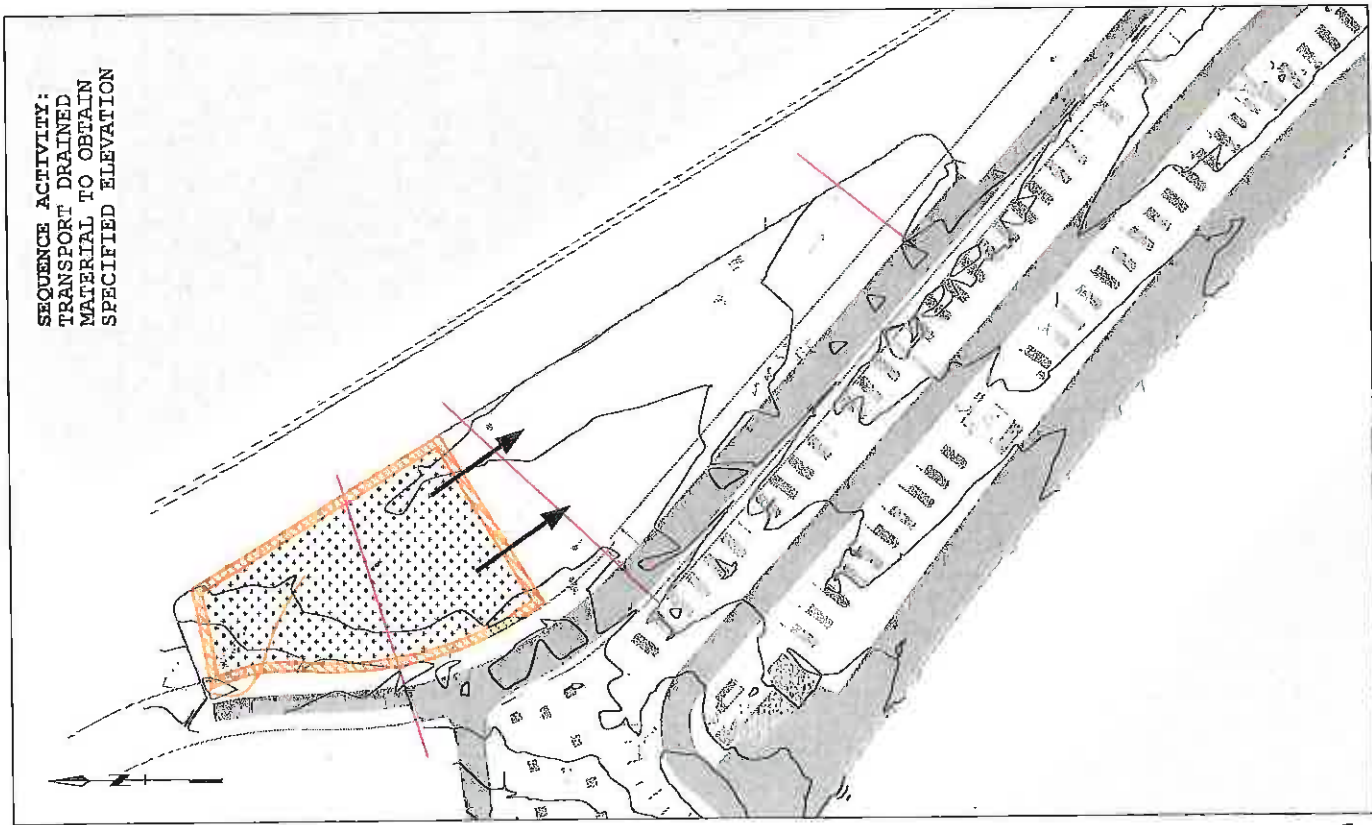

SEQUENCE #4: TRANSPORT MATERIAL
 SCALE 1" : 80'

EMC-Engineers-Scientists, LLC-Oregon-US-Oct 28, 2020.XLSX

Client: Jack Amin - EMC-Engineers-Scientists, LLC-Oregon-US	Date: Oct 28, 2020
Project: SPM	Author: MURDOCH



Mixture Details

Solids concentration in the mixture	22%
% by volume	48%
corresponding to % by weight	
Solid Particle Dimension	200 > 15 mm
Particle Median Diameter	3 kg/m ³
Liquid SG	1.25 kg/m ³
Solids SG	0.001 P/s
Mixture Specific Gravity	
Fluid dynamic Viscosity	

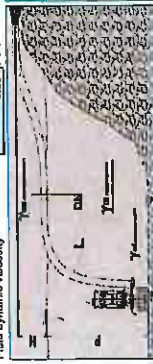

Application Details

Geodetic Height (AH) =	21 m
Geodetic Height (Vahly) =	152 m
Pipeline Total Length =	3000 ft
L =	914.4 m
Pipe Internal Diameter =	7.875 inch
DN	200
Total Mixture Capacity	472 m ³ /h
	12000 GPM

System TDH at best capacity

Slurry (m)	115.7
Slurry (ft)	381
Slurry (m)	1.5
Slurry (ft)	4.9
Slurry (m)	18.5
Slurry (ft)	60.7
Slurry (m)	133.7
Slurry (ft)	438.7
Mixture velocity inside the pipeline	8.0 m/s

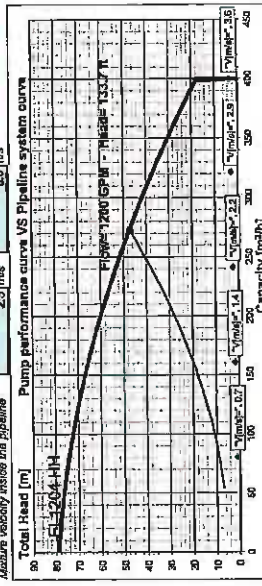

The above values are based on theoretical calculations. The solid concentration can vary from 20% to 60% since capacity can be the limit of material to be pumped, the delivery distance, the working depth, the static head and to the ability of the operator to keep the pump's agitator in constant contact with the material to be pumped.

SEDIMENT DRAGFLOW SPECIFICATIONS

SECTION AA PROFILE

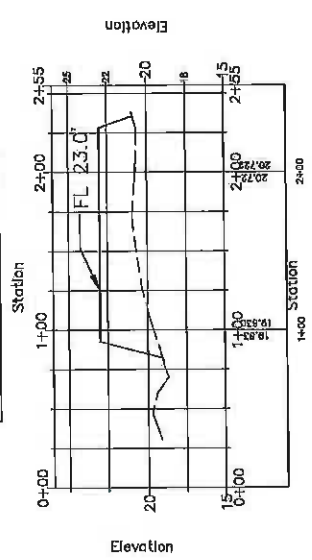

SECTION BB PROFILE

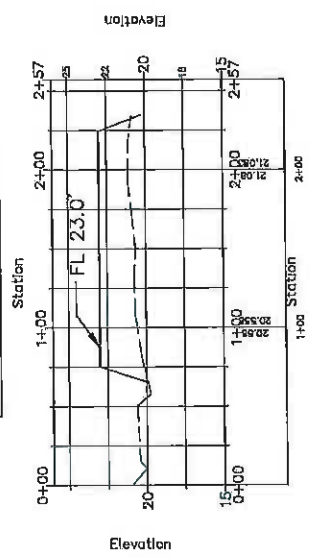

SECTION CC PROFILE

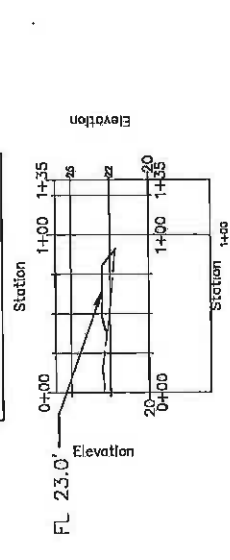

CROSS-SECTIONS NTS
SEE DRAWING C2.2





NO.	DATE	REVISION



KITE FIELD RV PARK PRELIMINARY LAYOUT
 SCALE 1"=50'

APPLICABLE CODES

THE CONTRACTOR SHALL BE RESPONSIBLE FOR OBTAINING ALL APPLICABLE CODES, ORDINANCES, REGULATIONS AND STANDARDS THAT APPLY TO THE PROJECT. THE CONTRACTOR SHALL BE RESPONSIBLE FOR OBTAINING ALL APPLICABLE CODES, ORDINANCES, REGULATIONS AND STANDARDS THAT APPLY TO THE PROJECT. THE CONTRACTOR SHALL BE RESPONSIBLE FOR OBTAINING ALL APPLICABLE CODES, ORDINANCES, REGULATIONS AND STANDARDS THAT APPLY TO THE PROJECT.

PAVEMENT MARKING NOTES

1. ALL PAVEMENT MARKING SHALL BE DONE IN ACCORDANCE WITH THE LATEST EDITION OF THE MICHIGAN MANUAL ON PAVEMENT MARKING.
2. ALL PAVEMENT MARKING SHALL BE DONE IN ACCORDANCE WITH THE LATEST EDITION OF THE MICHIGAN MANUAL ON PAVEMENT MARKING.

ADA NOTES

1. ALL WORK SHALL BE DONE IN ACCORDANCE WITH THE LATEST EDITION OF THE MICHIGAN MANUAL ON PAVEMENT MARKING.
2. ALL WORK SHALL BE DONE IN ACCORDANCE WITH THE LATEST EDITION OF THE MICHIGAN MANUAL ON PAVEMENT MARKING.

INSPECTION AND TESTING NOTES

1. THE CONTRACTOR SHALL BE RESPONSIBLE FOR OBTAINING ALL APPLICABLE CODES, ORDINANCES, REGULATIONS AND STANDARDS THAT APPLY TO THE PROJECT.
2. THE CONTRACTOR SHALL BE RESPONSIBLE FOR OBTAINING ALL APPLICABLE CODES, ORDINANCES, REGULATIONS AND STANDARDS THAT APPLY TO THE PROJECT.

GRADING NOTES

1. ALL GRADING SHALL BE DONE IN ACCORDANCE WITH THE LATEST EDITION OF THE MICHIGAN MANUAL ON PAVEMENT MARKING.
2. ALL GRADING SHALL BE DONE IN ACCORDANCE WITH THE LATEST EDITION OF THE MICHIGAN MANUAL ON PAVEMENT MARKING.

STORM DRAIN NOTES

1. ALL STORM DRAIN SHALL BE DONE IN ACCORDANCE WITH THE LATEST EDITION OF THE MICHIGAN MANUAL ON PAVEMENT MARKING.
2. ALL STORM DRAIN SHALL BE DONE IN ACCORDANCE WITH THE LATEST EDITION OF THE MICHIGAN MANUAL ON PAVEMENT MARKING.

SANITARY SEWER NOTES

1. ALL SANITARY SEWER SHALL BE DONE IN ACCORDANCE WITH THE LATEST EDITION OF THE MICHIGAN MANUAL ON PAVEMENT MARKING.
2. ALL SANITARY SEWER SHALL BE DONE IN ACCORDANCE WITH THE LATEST EDITION OF THE MICHIGAN MANUAL ON PAVEMENT MARKING.

WATER NOTES

1. ALL WATER NOTES SHALL BE DONE IN ACCORDANCE WITH THE LATEST EDITION OF THE MICHIGAN MANUAL ON PAVEMENT MARKING.
2. ALL WATER NOTES SHALL BE DONE IN ACCORDANCE WITH THE LATEST EDITION OF THE MICHIGAN MANUAL ON PAVEMENT MARKING.

GENERAL NOTES

1. ALL WORK SHALL BE DONE IN ACCORDANCE WITH THE LATEST EDITION OF THE MICHIGAN MANUAL ON PAVEMENT MARKING.
2. ALL WORK SHALL BE DONE IN ACCORDANCE WITH THE LATEST EDITION OF THE MICHIGAN MANUAL ON PAVEMENT MARKING.
3. ALL WORK SHALL BE DONE IN ACCORDANCE WITH THE LATEST EDITION OF THE MICHIGAN MANUAL ON PAVEMENT MARKING.
4. ALL WORK SHALL BE DONE IN ACCORDANCE WITH THE LATEST EDITION OF THE MICHIGAN MANUAL ON PAVEMENT MARKING.
5. ALL WORK SHALL BE DONE IN ACCORDANCE WITH THE LATEST EDITION OF THE MICHIGAN MANUAL ON PAVEMENT MARKING.
6. ALL WORK SHALL BE DONE IN ACCORDANCE WITH THE LATEST EDITION OF THE MICHIGAN MANUAL ON PAVEMENT MARKING.
7. ALL WORK SHALL BE DONE IN ACCORDANCE WITH THE LATEST EDITION OF THE MICHIGAN MANUAL ON PAVEMENT MARKING.
8. ALL WORK SHALL BE DONE IN ACCORDANCE WITH THE LATEST EDITION OF THE MICHIGAN MANUAL ON PAVEMENT MARKING.
9. ALL WORK SHALL BE DONE IN ACCORDANCE WITH THE LATEST EDITION OF THE MICHIGAN MANUAL ON PAVEMENT MARKING.
10. ALL WORK SHALL BE DONE IN ACCORDANCE WITH THE LATEST EDITION OF THE MICHIGAN MANUAL ON PAVEMENT MARKING.
11. ALL WORK SHALL BE DONE IN ACCORDANCE WITH THE LATEST EDITION OF THE MICHIGAN MANUAL ON PAVEMENT MARKING.
12. ALL WORK SHALL BE DONE IN ACCORDANCE WITH THE LATEST EDITION OF THE MICHIGAN MANUAL ON PAVEMENT MARKING.
13. ALL WORK SHALL BE DONE IN ACCORDANCE WITH THE LATEST EDITION OF THE MICHIGAN MANUAL ON PAVEMENT MARKING.
14. ALL WORK SHALL BE DONE IN ACCORDANCE WITH THE LATEST EDITION OF THE MICHIGAN MANUAL ON PAVEMENT MARKING.
15. ALL WORK SHALL BE DONE IN ACCORDANCE WITH THE LATEST EDITION OF THE MICHIGAN MANUAL ON PAVEMENT MARKING.
16. ALL WORK SHALL BE DONE IN ACCORDANCE WITH THE LATEST EDITION OF THE MICHIGAN MANUAL ON PAVEMENT MARKING.
17. ALL WORK SHALL BE DONE IN ACCORDANCE WITH THE LATEST EDITION OF THE MICHIGAN MANUAL ON PAVEMENT MARKING.
18. ALL WORK SHALL BE DONE IN ACCORDANCE WITH THE LATEST EDITION OF THE MICHIGAN MANUAL ON PAVEMENT MARKING.
19. ALL WORK SHALL BE DONE IN ACCORDANCE WITH THE LATEST EDITION OF THE MICHIGAN MANUAL ON PAVEMENT MARKING.
20. ALL WORK SHALL BE DONE IN ACCORDANCE WITH THE LATEST EDITION OF THE MICHIGAN MANUAL ON PAVEMENT MARKING.
21. ALL WORK SHALL BE DONE IN ACCORDANCE WITH THE LATEST EDITION OF THE MICHIGAN MANUAL ON PAVEMENT MARKING.
22. ALL WORK SHALL BE DONE IN ACCORDANCE WITH THE LATEST EDITION OF THE MICHIGAN MANUAL ON PAVEMENT MARKING.
23. ALL WORK SHALL BE DONE IN ACCORDANCE WITH THE LATEST EDITION OF THE MICHIGAN MANUAL ON PAVEMENT MARKING.
24. ALL WORK SHALL BE DONE IN ACCORDANCE WITH THE LATEST EDITION OF THE MICHIGAN MANUAL ON PAVEMENT MARKING.
25. ALL WORK SHALL BE DONE IN ACCORDANCE WITH THE LATEST EDITION OF THE MICHIGAN MANUAL ON PAVEMENT MARKING.
26. ALL WORK SHALL BE DONE IN ACCORDANCE WITH THE LATEST EDITION OF THE MICHIGAN MANUAL ON PAVEMENT MARKING.
27. ALL WORK SHALL BE DONE IN ACCORDANCE WITH THE LATEST EDITION OF THE MICHIGAN MANUAL ON PAVEMENT MARKING.
28. ALL WORK SHALL BE DONE IN ACCORDANCE WITH THE LATEST EDITION OF THE MICHIGAN MANUAL ON PAVEMENT MARKING.
29. ALL WORK SHALL BE DONE IN ACCORDANCE WITH THE LATEST EDITION OF THE MICHIGAN MANUAL ON PAVEMENT MARKING.
30. ALL WORK SHALL BE DONE IN ACCORDANCE WITH THE LATEST EDITION OF THE MICHIGAN MANUAL ON PAVEMENT MARKING.
31. ALL WORK SHALL BE DONE IN ACCORDANCE WITH THE LATEST EDITION OF THE MICHIGAN MANUAL ON PAVEMENT MARKING.
32. ALL WORK SHALL BE DONE IN ACCORDANCE WITH THE LATEST EDITION OF THE MICHIGAN MANUAL ON PAVEMENT MARKING.
33. ALL WORK SHALL BE DONE IN ACCORDANCE WITH THE LATEST EDITION OF THE MICHIGAN MANUAL ON PAVEMENT MARKING.
34. ALL WORK SHALL BE DONE IN ACCORDANCE WITH THE LATEST EDITION OF THE MICHIGAN MANUAL ON PAVEMENT MARKING.

344



Engineering & Construction
10000 Old Orchard Road, Suite 100
Charlotte, NC 28226
Phone: 704.486.1111
Fax: 704.486.1112
www.emcnc.com



Professional Engineer
No. 12345
State of North Carolina
Exp. 12/31/2024

PORT OF BROOKINGS HARBOR
1630 LOWER HARBOR ROAD, BROOKINGS, OR 97415
KITE FIELD RV PARK

DRAWN BY: TAYLOR
DATE: 7/10/21
JOB NO: 20-333
C4.1
GENERAL NOTES



DRAWN BY: TAJ
DATE: 1/20/21
JOB NO: 20-XXX
C5.0
ECS
STANDARD
DETAILS

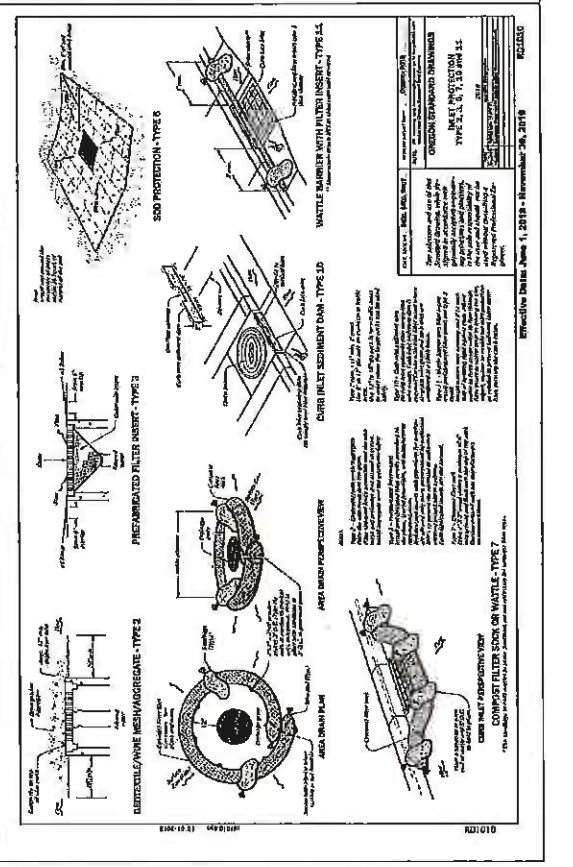
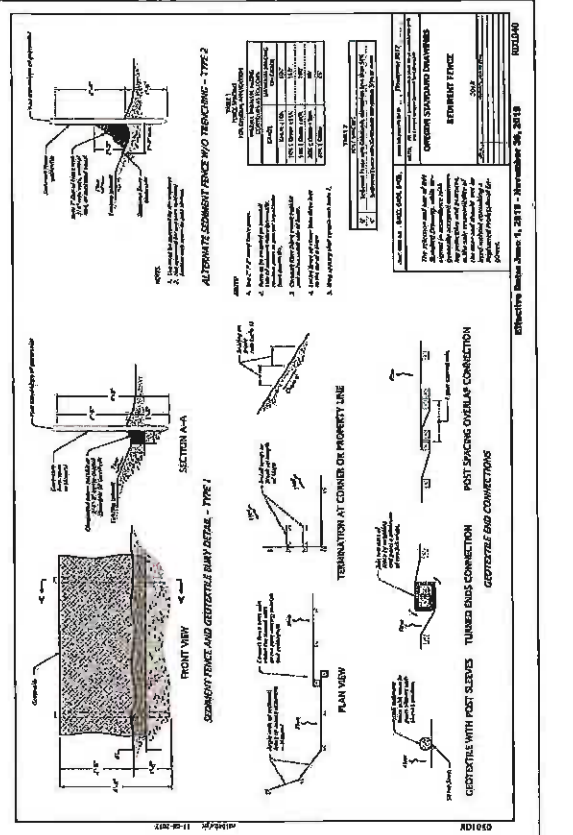
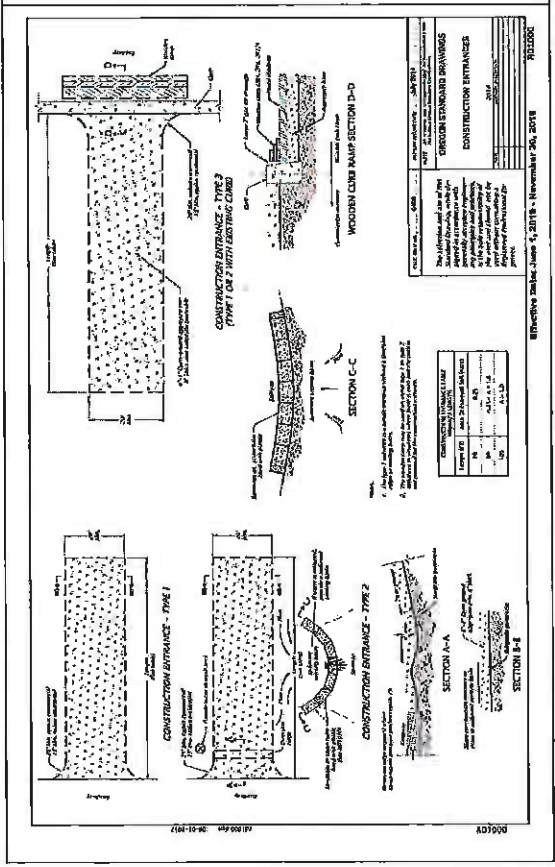
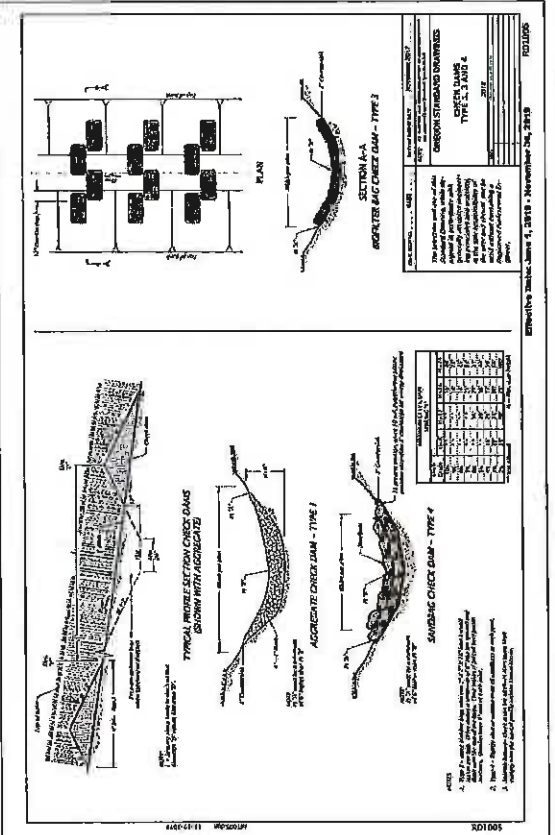

ESCP STANDARD NOTES:

- 1. THE CONTRACTOR SHALL MAINTAIN ALL ESCP AND BEST MANAGEMENT PRACTICES (BMP) THROUGHOUT THE CONSTRUCTION PROCESS... 2. ALL INSPECTIONS MUST BE MADE IN ACCORDANCE WITH THE ESCP PERMIT REQUIREMENTS... 3. INSPECTION LOGS MUST BE MAINTAINED WITH DETAILED RECORDS... 4. RECORDS OF THE ESCP MUST BE MAINTAINED THROUGHOUT THE CONSTRUCTION PERIOD... 5. ALL PERMIT REQUIREMENTS MUST BE MET... 6. THE ESCP MUST BE ACCURATE AND REFLECT THE CONSTRUCTION... 7. THE ESCP MUST BE ACCURATE AND REFLECT THE CONSTRUCTION... 8. THE ESCP MUST BE ACCURATE AND REFLECT THE CONSTRUCTION... 9. THE ESCP MUST BE ACCURATE AND REFLECT THE CONSTRUCTION... 10. THE ESCP MUST BE ACCURATE AND REFLECT THE CONSTRUCTION... 11. THE ESCP MUST BE ACCURATE AND REFLECT THE CONSTRUCTION... 12. THE ESCP MUST BE ACCURATE AND REFLECT THE CONSTRUCTION... 13. THE ESCP MUST BE ACCURATE AND REFLECT THE CONSTRUCTION... 14. THE ESCP MUST BE ACCURATE AND REFLECT THE CONSTRUCTION... 15. THE ESCP MUST BE ACCURATE AND REFLECT THE CONSTRUCTION... 16. THE ESCP MUST BE ACCURATE AND REFLECT THE CONSTRUCTION... 17. THE ESCP MUST BE ACCURATE AND REFLECT THE CONSTRUCTION... 18. THE ESCP MUST BE ACCURATE AND REFLECT THE CONSTRUCTION... 19. THE ESCP MUST BE ACCURATE AND REFLECT THE CONSTRUCTION... 20. THE ESCP MUST BE ACCURATE AND REFLECT THE CONSTRUCTION... 21. THE ESCP MUST BE ACCURATE AND REFLECT THE CONSTRUCTION... 22. THE ESCP MUST BE ACCURATE AND REFLECT THE CONSTRUCTION... 23. THE ESCP MUST BE ACCURATE AND REFLECT THE CONSTRUCTION... 24. THE ESCP MUST BE ACCURATE AND REFLECT THE CONSTRUCTION... 25. THE ESCP MUST BE ACCURATE AND REFLECT THE CONSTRUCTION... 26. THE ESCP MUST BE ACCURATE AND REFLECT THE CONSTRUCTION... 27. THE ESCP MUST BE ACCURATE AND REFLECT THE CONSTRUCTION... 28. THE ESCP MUST BE ACCURATE AND REFLECT THE CONSTRUCTION... 29. THE ESCP MUST BE ACCURATE AND REFLECT THE CONSTRUCTION... 30. THE ESCP MUST BE ACCURATE AND REFLECT THE CONSTRUCTION... 31. THE ESCP MUST BE ACCURATE AND REFLECT THE CONSTRUCTION... 32. THE ESCP MUST BE ACCURATE AND REFLECT THE CONSTRUCTION... 33. THE ESCP MUST BE ACCURATE AND REFLECT THE CONSTRUCTION... 34. THE ESCP MUST BE ACCURATE AND REFLECT THE CONSTRUCTION... 35. THE ESCP MUST BE ACCURATE AND REFLECT THE CONSTRUCTION... 36. THE ESCP MUST BE ACCURATE AND REFLECT THE CONSTRUCTION... 37. THE ESCP MUST BE ACCURATE AND REFLECT THE CONSTRUCTION... 38. THE ESCP MUST BE ACCURATE AND REFLECT THE CONSTRUCTION... 39. THE ESCP MUST BE ACCURATE AND REFLECT THE CONSTRUCTION... 40. THE ESCP MUST BE ACCURATE AND REFLECT THE CONSTRUCTION...

WET WEATHER CONSTRUCTION

THE CONTRACTOR SHALL MAINTAIN ALL ESCP AND BEST MANAGEMENT PRACTICES (BMP) THROUGHOUT THE CONSTRUCTION PROCESS... THE CONTRACTOR SHALL MAINTAIN ALL ESCP AND BEST MANAGEMENT PRACTICES (BMP) THROUGHOUT THE CONSTRUCTION PROCESS...

ESCP STANDARD NOTES:

- 1. THE CONTRACTOR SHALL MAINTAIN ALL ESCP AND BEST MANAGEMENT PRACTICES (BMP) THROUGHOUT THE CONSTRUCTION PROCESS... 2. ALL INSPECTIONS MUST BE MADE IN ACCORDANCE WITH THE ESCP PERMIT REQUIREMENTS... 3. INSPECTION LOGS MUST BE MAINTAINED WITH DETAILED RECORDS... 4. RECORDS OF THE ESCP MUST BE MAINTAINED THROUGHOUT THE CONSTRUCTION PERIOD... 5. ALL PERMIT REQUIREMENTS MUST BE MET... 6. THE ESCP MUST BE ACCURATE AND REFLECT THE CONSTRUCTION... 7. THE ESCP MUST BE ACCURATE AND REFLECT THE CONSTRUCTION... 8. THE ESCP MUST BE ACCURATE AND REFLECT THE CONSTRUCTION... 9. THE ESCP MUST BE ACCURATE AND REFLECT THE CONSTRUCTION... 10. THE ESCP MUST BE ACCURATE AND REFLECT THE CONSTRUCTION... 11. THE ESCP MUST BE ACCURATE AND REFLECT THE CONSTRUCTION... 12. THE ESCP MUST BE ACCURATE AND REFLECT THE CONSTRUCTION... 13. THE ESCP MUST BE ACCURATE AND REFLECT THE CONSTRUCTION... 14. THE ESCP MUST BE ACCURATE AND REFLECT THE CONSTRUCTION... 15. THE ESCP MUST BE ACCURATE AND REFLECT THE CONSTRUCTION... 16. THE ESCP MUST BE ACCURATE AND REFLECT THE CONSTRUCTION... 17. THE ESCP MUST BE ACCURATE AND REFLECT THE CONSTRUCTION... 18. THE ESCP MUST BE ACCURATE AND REFLECT THE CONSTRUCTION... 19. THE ESCP MUST BE ACCURATE AND REFLECT THE CONSTRUCTION... 20. THE ESCP MUST BE ACCURATE AND REFLECT THE CONSTRUCTION... 21. THE ESCP MUST BE ACCURATE AND REFLECT THE CONSTRUCTION... 22. THE ESCP MUST BE ACCURATE AND REFLECT THE CONSTRUCTION... 23. THE ESCP MUST BE ACCURATE AND REFLECT THE CONSTRUCTION... 24. THE ESCP MUST BE ACCURATE AND REFLECT THE CONSTRUCTION... 25. THE ESCP MUST BE ACCURATE AND REFLECT THE CONSTRUCTION... 26. THE ESCP MUST BE ACCURATE AND REFLECT THE CONSTRUCTION... 27. THE ESCP MUST BE ACCURATE AND REFLECT THE CONSTRUCTION... 28. THE ESCP MUST BE ACCURATE AND REFLECT THE CONSTRUCTION... 29. THE ESCP MUST BE ACCURATE AND REFLECT THE CONSTRUCTION... 30. THE ESCP MUST BE ACCURATE AND REFLECT THE CONSTRUCTION...

Table with 2 columns: SITE CONTROL, INSPECTION FREQUENCY, MINIMUM FREQUENCY. Rows include 1. ACTIVE PERIODS, 2. PRIOR TO THE START OF CONSTRUCTION, 3. DURING CONSTRUCTION, 4. AFTER CONSTRUCTION, 5. PRIOR TO THE START OF CONSTRUCTION, 6. DURING CONSTRUCTION, 7. AFTER CONSTRUCTION.

IMPLEMENTATION OF CONTROL MEASURES:

A. ALL ESCP MEASURES MUST BE INSTALLED AND MAINTAINED THROUGHOUT THE CONSTRUCTION PROCESS... B. ALL PERMIT REQUIREMENTS MUST BE MET... C. THE ESCP MUST BE ACCURATE AND REFLECT THE CONSTRUCTION... D. THE ESCP MUST BE ACCURATE AND REFLECT THE CONSTRUCTION... E. THE ESCP MUST BE ACCURATE AND REFLECT THE CONSTRUCTION...

INSPECTION FREQUENCY:

- HED A PRE-CON MEETING OF PRODUCT CONSTRUCTION PERSONNEL THAT INCLUDES THE ESCP MANAGER... - INSPECTION LOGS MUST BE MAINTAINED WITH DETAILED RECORDS... - CHANGES TO THE APPROVED ESCP PLAN MUST BE SUBMITTED TO DEC IN THE FORM OF AN ACTION PLAN.

RATIONAL STATEMENT

THE ESCP MANAGER SHALL MAINTAIN ALL ESCP AND BEST MANAGEMENT PRACTICES (BMP) THROUGHOUT THE CONSTRUCTION PROCESS... THE ESCP MANAGER SHALL MAINTAIN ALL ESCP AND BEST MANAGEMENT PRACTICES (BMP) THROUGHOUT THE CONSTRUCTION PROCESS...

STOCKPILE SOILS

TEMPORARY STOCKPILE LOCATIONS MUST BE IDENTIFIED BY CONTRACTOR BEFORE CONSTRUCTION BEGINS... STOCKPILES SHALL NOT BE PLACED WITHIN PROTECTED AREAS... STOCKPILES SHALL NOT BE PLACED WITHIN PROTECTED AREAS...

CONSTRUCTION ACTIVITY / ESTIMATED TIME

TO BE DETERMINED... TO BE DETERMINED... TO BE DETERMINED... TO BE DETERMINED... TO BE DETERMINED... TO BE DETERMINED... TO BE DETERMINED... TO BE DETERMINED... TO BE DETERMINED... TO BE DETERMINED...

ENGINEER

SAC - ENVIRONMENTAL ENGINEERS, LLC
1500 NORTH CENTRAL AVENUE
SUITE 200
CHICAGO, ILLINOIS 60610

NARRATIVE DESCRIPTIONS

EXISTING SITE CONDITIONS
UNPAVED PARKING LOTS, OUTSIDE STORAGE, RECREATIONAL FIELD, SOFT SAND
PAVED PARKING LOTS, EXTERNAL WATER PUMP SYSTEM, UTILITY, RECREATIONAL, LOGS, USE, PAVED
SOFT SAND



PORT OF BROOKINGS HARBOR
1630 LOWER HARBOR ROAD, BROOKINGS, OR 97416
KITE FIELD RV PARK

DRAWN BY: TAM
DATE: 1/7/01
JOB NO: 20-1111
ECS
GENERAL NOTES

SHEET INDEX
GENERAL NOTES
EROSION AND SEDIMENT CONTROL PLAN
EROSION AND SEDIMENT CONTROL DETAILS